



Your success hangs on the reliability of every component.

CNC TOOLING SOLUTIONS
FROM SPINDLE TO WORKPIECE



2017

Techniks is synonymous with toolholders, but...

...the key to our success is our people, who go the extra mile every day to ensure you are delighted with our service and products. Becoming a Techniks customer means you have a hard working partner, helping you grow your business by providing great products at competitive prices.

Key Points:

- live phone support M-F, 8-6
- expert technical support
- Techniks Certified quality



Need cutting tools?
Request our Cutting Tools catalog or view it online:
www.techniksusa.com

Techniks features dynamic product lines of versatile toolholders for any application.



PowerCOAT Nut*



Extended Lengths



CoolBLAST HPC

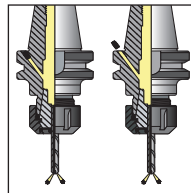

CoolFLEX DIN B



Slim Nose Options



DualDrive Dual-Contact

Holder Type	Spindle Sizes	Certified	Ext. Length	CoolBLAST	CoolFLEX	Slim Nose	DualDRIVE	C4,5,6
ER Collet Chucks	BT30/40/50, CAT40/50, HSK, TG, ISO, SK30, SS	✓	✓	✓	✓	✓	✓	✓
End Mill Holder	BT30/40/50, CAT40/50, HSK63A, HSK100A	✓	✓	✓	✓	✓	✓	✓
ShrinkFIT	BT30/40, CAT40/50, HSK, HSKA, SFS12	✓	✓	✓	✓	✓	✓	✓
SlimFIT System (drawbar collet)	BT30/40, CAT40/50, HSK, extensions	✓	✓	✓	✓	✓	✓	✓
Face Mill Arbor	BT30/40/50, CAT40/50, HSKA, R8	✓	✓	✓	✓	✓	✓	✓
Hydraulic Toolholders	BT30/40, CAT40/50, HSKA, HSKF	✓	✓	✓	✓	✓	✓	✓
Milling Chuck	BT40, CAT40/50, HSK	✓	✓	✓	✓	✓	✓	✓
Morse Taper	BT30/40/50, CAT40/50	✓	✓	✓	✓	✓	✓	✓
Drill Chuck	BT30/40, CAT40/50, HSK, ISO30	✓	✓	✓	✓	✓	✓	✓

Call Toll Free: 800.597.3921 or 317.803.8000 • Fax: 877.776.9994 or 317.803.8001
email: info@techniksusa.com • Office Hours: M - F, 8:00 am to 6:00 pm E.S.T.

Techniks Inc., 9930 E. 56th St., Indianapolis, IN 46236

Catalog Section Guide – Full Table of Contents pgs. 2–4

Collet & Nut Holders



page 15

Collets & Nuts



page 49

End Mill Holders



page 75

ShrinkFIT Holders



page 93

Face Mill Arbors



page 119

Other Holders



page 129

Turn/Mill Tooling



page 149

Tap Holders



page 159

Boring Tools



page 171

Setup Equipment



page 227

Magnetic Workholding



page 237

Lifting & Deburring



page 263

Collet Chucks, Collets, End Mill Holders, ShrinkFIT

Collet & Nut Holders

SlimFIT Holders



SlimFIT Narrow Nose.....	16
CAT40/50 SlimFIT.....	16
BT30/40 SlimFIT	17
HSK63A SlimFIT	18

CAT40 Holders

ER Collet Chucks.....	22
ER CoolFLEX.....	23
ER Mini Nut.....	24
ER SuperRIGID	25
DualDRIVE Dual-Contact.....	26

CAT50 Holders

ER Collet Chucks.....	27
ER CoolFLEX.....	28
ER Mini Nut.....	29
ER SuperRIGID.....	30
DualDRIVE Dual-Contact.....	31

BT30 Holders

BT30ER Holders	32
BT30ER Mini Nut	32
BT30 DualDRIVE.....	33
BT40 ER Holders	35
BT40 ER CoolFLEX	35
BT40 ER Mini Nut.....	36
BT40 ER SuperRIGID	37
BT50 ER Holders	38

HSK Holders

HSK63A ER Holders	39
HSK100A ER Holder	40

CNC Router Holders

ISO ER, SK SYOZ Holders.....	41
BT30, BT35 Holders	42
HSKE & F ER Holders.....	42

Straight Shank Holders

ER Straight Shank Holders ...	44
ER Coolant Straight Shanks ...	45

TG Holders

TG75, TG100 Holders	46
---------------------------	----

Set Screws & Specials

Set Screws & Torque Chart....	41
Special Order Holders.....	42

Collets and Nuts

ER Collets



ER Inch Sizes.....	51
ER Metric Sizes	52
ETS-DNA "Dead Nuts"	54

ER Coolant Collets

ER Steel Sealed Inch	56
ER Steel Sealed Metric	57
ER Sealed Collets	58

Tap Collets

ER Floating Tap Collets	59
ER Rigid Tap Collets.....	60
ER Quick-Change Collets.....	62
Collet Storage Trays.....	63

PowerCOAT Nuts

PowerCOAT Nuts	64
----------------------	----

Black Gold Coolant Rings

ER Coolant Rings.....	66
-----------------------	----

TG Collets

TG75 Collets and Nut	68
TG100 Collets and Nut	69
TG100 Coolant Collets.....	70
TG150 Collets.....	71

Other Collets

SYOZ / EOC Collets.....	72
Double Angle DA Collets.....	73

Collet Specifications

Identification / Torque.....	74
------------------------------	----

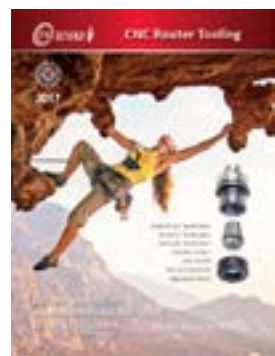

Call (800) 597-3921 to get our CNC Router Tooling catalog.

End Mill Holders

CAT40



Stubby Length.....	76
Regular Length.....	76
Extended Lengths.....	77
Rigid Reach	77



CoolBLAST Holders.....	78
CoolFLEX Holders.....	79
CoolBLAST & CoolFLEX	79
DualDRIVE Dual-Contact.....	81



CAT50

Stubby Length.....	82
Regular Length.....	82
Extended Length	83
Rigid Reach	83
CoolBLAST	84
CoolFLEX.....	85
DualDRIVE Dual-Contact.....	86

BT30

DualDRIVE Dual-Contact	87
Regular Length	87

BT40

Regular Length.....	88
Extended Length	89
Rigid Reach.....	89
CoolFLEX.....	90

BT50

Regular and Extended	91
----------------------------	----



HSK

HSK63A, HSK100A	92
-----------------------	----



End Mill Lock Screws

Replacement Screws	91
--------------------------	----

ShrinkFIT Holders

CAT40



Regular Length.....	94
Extended Length	95
SlimLINE - small nose	95
Metric Size	96
CoolBLAST Holders	97
CoolFLEX Holders.....	98
CoolBLAST with CoolFLEX....	98
DualDRIVE Dual-Contact.....	99

CAT50

Regular Length.....	100
Extended Length	100
Metric Size	101
CoolBLAST Holders	102

BT30, BT40

BT30 Regular Length	103
BT30 DualDRIVE.....	103
BT40 Inch & Metric	104

HSKE

HSK40E Inch and Metric....	105
HSK40E SlimLINE.....	105
HSK50E Holders	105

HSKA

HSK63A Regular Length....	106
HSK63A Extended	106
HSK63A SlimLINE.....	106
HSK63A Metric Sizes.....	107
HSK63A CoolBLAST.....	107
HSK100A Holders.....	108

CNC Router ShrinkFIT

HSK63F and ISO30.....	110
-----------------------	-----



SFS12 ShrinkFIT

SFS12 Holders	112
SFS12 Adapters.....	113

ShrinkFIT Extensions

ShrinkFIT Extensions	104
----------------------------	-----

ShrinkFIT Machines

ShrinkSTATION	105
ShrinkPRO	107
ShrinkPRO Quencher.....	108

Face Mill Arbors, Other Holders, Turn/Mill, Tapping

Face Mill Arbors

Face Mill Arbors



CAT40 Face Mill Arbors 120



CAT40 DualDRIVE..... 121

CAT50 Face Mill Arbors 122

CAT50 DualDRIVE 123



BT30 DualDRIVE..... 124



BT30 Face Mill Arbors 124

BT40 Face Mill Arbors 125

BT50 Face Mill Arbors 125



HSK Face Mill Arbors 126

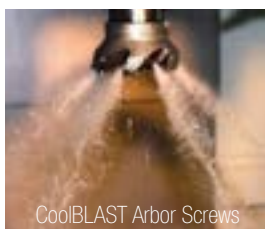

CoolBLAST Arbor Screws



Arbor Screws..... 128

Other Holders

Hydraulic Toolholders



CAT40, CAT50 131

BT30, BT40 133

HSK63 134

HSK100A..... 135

Reduction Sleeves..... 136

Milling Chucks



CAT40, 50, CoolBLAST 137

CAT40, 50 DualDRIVE..... 138

BT40 and HSK..... 139

Reduction Sleeves..... 140

CAT & HSK Tool Blanks



CAT40/50, HSK63A/100A .. 141

Morse Taper



CAT40, CAT50 142

BT30, BT40, BT50 143

SIMIS Toolholders



CAT40, 50 Collet Chucks 144

CAT40, 50 EMH 145

Drill Chucks



HP3 High Precision..... 146

Keyless Jacobs Chucks 146

CAT, BT, HSK, SPU Chucks .. 147

CAT, BT Chuck Holders 148

C4, C5, C6 Turn/Mill

Collet Chucks



C4 Collet Chucks 150

C5 Collet Chucks 150

C6 Collet Chucks 150

SlimFIT Holders



C4 SlimFIT Holders 151

C6 SlimFIT Holders 151

SlimFIT Extensions 151

End Mill Holders



C4 End Mill Holders 152

C6 End Mill Holders 152

ShrinkFIT Holders



C4 ShrinkFIT Holders..... 153

C5 ShrinkFIT Holders..... 153

C6 ShrinkFIT Holders..... 153

Face Mill Arbors



C4 Face Mill Arbors 154

C5 Face Mill Arbors 154

C6 Face Mill Arbors 154

C6 External Turning



C6 Turning Tools 155

Tapping Systems

MicroFLOAT Rigid Tap



About MicroFLOAT 160



CAT, BT, HSK MicroFLOAT 162



Straight Shank MicroFLOAT 162



MicroFLOAT Extensions 163

Tension/Compression



CAT, BT Tap Chucks..... 164

HSK, Straight Shank 165

Rigid Tap



CAT, BT Tap Chucks..... 166

HSK, Straight Shank 167

ANSI Spec Tap Collets



Clutch Drive..... 168

Rigid Tap 169

Boring Tools, Setup Equipment, Workholding & Deburring

Pinzbohr Boring

BohrSTAR Kits



BohrSTAR 43 Triangular.....	173
BohrSTAR 43 Rhombic.....	174
BohrSTAR 100 Triangular....	175
BohrSTAR 100 Rhombic.....	176
BohrSTAR 170 Triangular....	177
BohrSTAR 170 Rhombic.....	178
BohrSTAR 210 Triangular....	179
BohrSTAR 210 Rhombic.....	180
BohrSTAR Kit Toolholders ...	181

Pinzbohr Boring Tools



Boring Bars	185
Micro Heads for Bars	187
Rough Heads.....	188
Finish Heads.....	192
UltraFINE	193

Cartridges & Inserts

Indexable Cartridges	199
Boring Inserts	200

Boring Head Toolholders

CAT40 Holders.....	204
CAT50 Holders.....	205
BT30, 40 Holders.....	207
BT50 Holders	208
HSK 50A, 63A, 100A.....	209
Weldon and R8 Holders.....	210
Large Head Holders	211

Extensions & Reducers

Extensions	213
Reducers.....	214
Chamfering Heads.....	214

Modular Toolholders

End Mill Holder.....	215
Face Mill Arbor	215
Feeds and Speeds.....	216

MacroBOHR



MacroBOHR.....	217
Spare Parts.....	221

Setup Equipment

Retention Knobs



CAT Retention Knobs.....	228
BT Retention Knobs.....	229
CNC Router Knobs.....	230
DAT Knobs (DIN 69871)	231
Special Order Knobs.....	231
Spindle Calibration Tool.....	231

Wrenches



Hand Wrenches.....	232
Torque Wrenches.....	233
Torque Wrench Adapters ...	233

Other Setup Equipment



Tightening Fixtures.....	234
--------------------------	-----



Spindle Wipers	235
----------------------	-----



Preset Gauges	235
---------------------	-----



Indicator Arms.....	272
---------------------	-----



Replacement Screws	236
HSK Coolant Pipe	236

Magnetic Workholding

MagVISE Workholding



About EEPM Chucks.....	239
EEPm CNC Chucks	240
EEPm Subplates	242

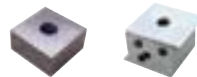

EEPm Induction Blocks.....	243
----------------------------	-----



EEPm-C Modular	244
EEPm-V Horizontal.....	246



EEPm-CIR Vertical Turning ..	248
EEPm-CIRS Round.....	250
EEPm-IT Index Table.....	251
EEPm-PIM Injection Mold ...	252

ECB Magnetic Vises



ECB Workholding Vises.....	253
----------------------------	-----

Surface Grinding Chucks



EDMT Variable Pole	256
EDTW Fine-Pole.....	257
EET Wide Pole	258
EET-W Fine Pole	259
Induction Blocks.....	260



Magnetic V-Blocks	261
Chuck Controllers.....	262
Demagnetizers.....	262

Magnetic Lifting

EZ-Lift Magnets



ELM Lifting Magnets	266
---------------------------	-----



Spreader Bars	266
---------------------	-----



Vertical Lifters	251
Calculating Loads.....	267
Custom Solutions	267

sPINner Deburring



Parts Deburring Service.....	268
sPINner Machines	271
Pin Media	271
Deburring Solution	271

Part Number Index

Part Number Index	
Products by part number....	273

Techniks is a partner you can truly depend on.

You know we make toolholders, but did you know we will work closely with you to understand your manufacturing needs, so we can provide the best possible solutions? Becoming a Techniks customer means you have an expert solutions partner who provides top quality products and excellent customer service backed by our satisfaction guarantee.

With Techniks you get:

- *inspected, tested and lab-certified products that provide outstanding value and extend perishable cutting tool life to save you money.*
- *full factory support before, during, and after the sale*
- *guaranteed turn-key CNC tooling and workholding solutions*
- *live phone support (toll-free) 8:00 am – 6:00 pm E.S.T.*
- *orders ship the same day they are received! (ground orders received by 2:00 pm, or expedited orders received by 5:00 pm)*
- *each order is checked 4 times before shipping. 99.9% average shipping accuracy (we track this each month)*
- *all products are backed by our 100% satisfaction guarantee*
- *training on how to use our products if needed*
- *24/7 access to request a quote, look up product information, request catalogs, on the web (www.techniksusa.com)*
- *receive promotions and product information by opt-in email*

The entire Techniks team is committed to excellent customer service for fast and accurate fulfillment of orders.

Thank You for considering Techniks for your CNC tooling needs.



Live phone support M-F, 8:00 am – 6:00 pm EST



Orders ship the same day they are received.



RoadShow live product demos at your facility.

Contact Information

Toll-Free: 800.597.3921

Local: 317.803.8000

Fax: 317.803.8001

email: info@techniksusa.com

Website: www.techniksusa.com

Hours: M-F, 8:00 am – 6:00 pm EST

Techniks Inc., 9930 E. 56th St.

Indianapolis, IN 46236



We stand behind all our products with our 100% Satisfaction Guarantee • www.techniksusa.com

Tooling Certificate Program for Machine Purchases

Wouldn't it be great if you could purchase your tooling when you finance your machine, and not have to pick out tools until you know exactly what you need?

Our Tooling Certificates bundle a tooling purchase in with your machine, so you can improve your cash flow and still have tools on-hand when you need them.

Here is how it works.

Purchase a Techniks Tooling Certificate

- ✓ Either from your machine tool dealer or your cutting tool distributor.



Purchase tools when you need them

- ✓ The tooling experts at Techniks will help you specify the tooling you need from our full-line CNC Tooling Solutions catalog.
- ✓ You are assured you are getting top quality **Techniks Certified Tooling**, plus our Factory Direct Support when you need it.
- ✓ You can redeem all or any portion of your Certificate value at any time, but the Certificate *does* expire after 1 year.

Prevent unexpected out-of-pocket expenses when you tool up your new machine.



Techniks Tooling Certificate

Redeem this certificate for tooling valued at:

\$ _____

Date: _____

Customer Name: _____ Company: _____

Distributor: _____ Signature: _____

This certificate entitles the above mentioned customer to select products from the Techniks CNC Tooling catalog, at the value stated above. Expiration is one year from the date above.



Techniks Certified = Quality Guaranteed

Collet Chucks, End Mill Holders, ShrinkFIT Holders, SlimFIT Tools, Face Mill Arbors



Techniks Certified Tooling means the critical features of each holder has been individually lab tested, measured and inspected for quality. Depending on the holder this can include: balance, dimensional accuracy, collet pocket runout (T.I.R.), bore I.D. and taper accuracy. Techniks Certified guarantees your holder will meet or beat our published specifications.

Lab Certified Accuracy

Each toolholder is lab certified for accuracy and balance.



Taper-to-Pocket T.I.R. 0.0001"

Measured from taper O.D. to collet pocket I.D.

Taper Accuracy AT3

Taper ground to AT3 accuracy for maximum contact with spindle.

Ultra Precision Collet

Each collet hand inspected. T.I.R. only 0.0002"



PowerCOAT Nuts

Our PowerCOAT nut holds 70% tighter than standard nuts for best T.I.R. and rigidity.



Balanced to 25,000 RPM

Factory balanced to 25,000 RPM at G2.5
Custom balancing to 60,000 RPM available.

Balanced Nut

Balanced nut reduces vibration to extend cutting tool life.

End Mill Holder Bore Tolerance is H5 – Best in the Industry – Improves Accuracy & Tool Life



Others T.I.R. .0008" Techniks .0002"

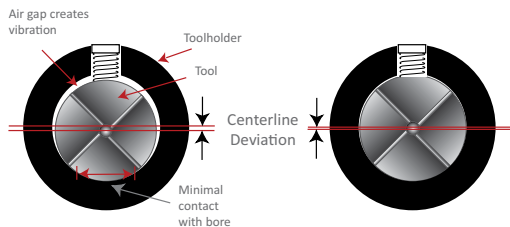

A full report comes with each holder

INSPECTION REPORT				
MODEL NO : SYTC-XXXXX	Balanced to G2.5 25,000 RPM			
CHECKED BY : SEE/EE COLLET CHECK FILE #				
TYPE :				
VIEW EXAMINED	DATE	BY	REMARKS	APPROVED
APPROVED	4/10/11	4/10/11	11.0mm	
TOLERANCE	4/10/11	4/10/11	11.0mm	
DATE	4/10/11	4/10/11	11.0mm	
Operator:	DATE:	BY:	FILE #:	
TEST REPORT OF BALANCE				
MODEL NO : SYTC-XXXXX	APPROXIMATE UNBALANCE	PER ISO 1940 SPECIFICATION : .50 gmm		
CHECKED BY : SEE/EE COLLET CHECK FILE #	TYPE :	SEVERAL UNBALANCE ALLOWED		
DATE :	DATE :	ONLY ONE		
UNBALANCE	UNBALANCE	CHANGE WITH SET		
UNBALANCE	UNBALANCE	CHANGE WITH COLLET AND FILE		
WARNING: Safe for the following plan WARNING: Safe for the following plan				

Use Techniks Certified holders to reduce T.I.R. and extended cutting tool life.



We stand behind all our products with our 100% Satisfaction Guarantee • www.techniksusa.com

NEW

What's New? At-a-Glance

NEW! – Hydraulic Toolholders (see page 130)

- CAT, BT, HSK, ISO
- Balanced 25,000 RPM



NEW! – Modular ShrinkFIT (see page 111)

- CAT, BT, HSK,
- Balanced 25,000 RPM



NEW! – 3-port Coolant-thru ShrinkFIT Toolholders (see ShrinkFIT Section)



- Expanded lineup of CAT, BT, HSK ShrinkFIT
- Increased pressure & easier tool removal

More Long Reach Tools!



- Expanded lineup of HSK collet chucks, end mill holders, ShrinkFIT and face mill arbors
- 8", 10", 12" lengths in stock
- CAT40, CAT50, HSK100A

NEW! – Heavy-Duty Chucks (see page 240)

- 70mm pole for up to 98,767 lbs holding power
- for extra-large, or extra-thick workpieces



NEW! –ShrinkSTATION

- change tools in only 6-8 seconds
- automatic air cycle
- handles tools up to 22" gauge lengths

(see page 116)



NEW! – Boring Heads Free Replacement *Guaranteed for any reason!*

- Applies to all of our boring heads



(see page 182)

NEW! –Roller Bearing Tightening Stands

- CAT, BT, HSK, ISO, C4-5-6
- faster tool changes
- eliminates slippage

(see page 234)



Road Show

Our Roadshow Events provide complimentary product and application information to your staff, all delivered to your door. Roadshow Event staff are experienced tooling specialists that provide an educational experience like no other, plus an opportunity to get hands-on with our tools.

What we will bring

- *Techniks Certified CNC toolholders*
- *Techniks cutting tools*
- *ShrinkFIT machines*
- *MagVISE magnetic workholding*
- *sPINner small parts deburring machine*
- *Other products you request us to bring*



What we will do

- The Techniks roadshow van arrives at your facility fully equipped to demonstrate the capabilities of our most popular products.
- Our factory reps will provide hands-on, one-on-one instructional training to show the most effective use of our tooling for your company's unique applications.

Contact us to schedule a Roadshow Event at your facility and don't forget to request specific products you would like to see. **No risk, no obligation!**

Call us at: 800.597.3921 to arrange a visit.



Featured: sPINner Parts Deburring Machine

Batch deburrs parts in minutes that take hours by hand.



Featured: ShrinkFIT Machines and Tooling



SFS-12 ShrinkFIT adapters are SK compatible and a great way to minimize toolholder purchases.

Request our Cutting Tools Catalog for Metalworking



Cutting Tools

Key Points:

- free cutter body program
- tooling packages and other special deals
- high-performance PVD inserts



For more information request our Cutting Tools catalog or view it online: www.technikusa.com



90° Face Mills



45° Face Mills

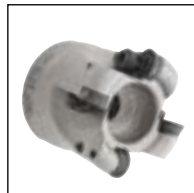

Button Cutter



Indexable End Mill



Helical Cutter



Turning / Boring

Face Mills	Diameters	Inserts	Insert Pockets	H6 Bore I.D.	ShrinkMILL	CoolBLAST
90° Facemills	2" 2.5" 3" 4" 5" 6"	APKT, APGT, APEX	4, 5, 6, 7, 8, 10	✓	✓	✓
45° Facemills	2" 3" 4" 5"	SEKT, SEET	4, 6, 7, 8	✓	✓	✓
45° Heavy-Duty	3" 4" 5" 6"	SNKX (8 edges)	5, 7, 8, 10	✓		✓
Positive High-Feed	2" 2.5" 3" 4"	SDKX	4, 5, 6, 7	✓		✓
Negative Cast Iron	3" 4" 5" 6"	PNEG (10 edges)	8, 10, 12, 14	✓		
Round Button	2" 3"	RDMT, RDMW, RDMX	4, 5	✓	✓	✓
Negative High-Feed	2" 2.5" 3" 4"	SNKX	4, 6, 7	✓	✓	✓

End Mills	Diameters	Inserts	Insert Pockets	PowerLOC	ShrinkLOC	CoolBLAST
Indexable End Mill	.5" up to 1.5"	APKT, APGT	1, 2, 3	✓	✓	✓
Positive High-Feed	.75" up to 1.25"	WPGT, SDMT, SDKX	2, 3			✓
Negative High-Feed	1" up to 1.25"	SNKX (8 edges)	3, 4	✓	✓	✓
90° Helical Cutter	.75" up to 1.25"	APKT	4, 8, 12			✓
Indexable Drill	2.5" up to 9"	WCMX	3, 4, 6, 8			✓

Turning Tools	Application	Lead Angle	Shank	L & R Hand	2-Side Insert	All Material
Negative Tool Holder	turning & facing	93°, 95°	1" square	✓	✓	✓
Negative Boring Bars*	boring & facing	93°, 95°	1" 1.25" 1.5"	✓	✓	✓
Positive Tool Holder	turning & facing	91°, 93°, 95°	.5" & .75"	✓		✓
Positive Boring Bars*	boring & facing	91°, 93°, 95°	.375" to .75"	✓		✓

*Coolant-thru is standard for better chip evacuation.

Request our CNC Router Tooling Catalog

Techniks Certified tools for wood production



Key Points:

- *Techniks Certified CNC router tools*
- *NEW! hydraulic toolholders*
- *Full line of aggregate heads*



Request our CNC Router catalog or view it online: www.techniksusa.com



HSK Holders & Arbors



AirPRO Dust Extraction



ShrinkFIT Machines



Hydraulic Holders



Tightening Fixtures



Aggregate Heads

Spindle Type	Collet & Nut*	Drill Chucks	ShrinkFIT	Hydraulic Holders	End Mill Holders	Face Mill Arbors	Moulder Head Arbors
BT 30/35/40	✓	✓	✓				
HSK-F 50/63	✓	✓	✓	✓	✓	✓	✓
HSK-E 32/40/50/63	✓		✓				
HSK63A			✓				
ISO 20/25/30/40	✓	✓	✓				✓
CMS	✓						

*All our collet and nut style holders include our PowerCOAT Nut that improves holding power by 75%.

Collet	ER	DNA	SYOZ	EOC	Shoda	Heian
Collet Sizes	ER8, E11, ER16, ER20, ER25, ER32, ER40, ER50	DNA11, DNA16, DNA20, DNA32	SYOZ20, SYOZ25	EOC8, EOC12, EOC16	Old Style, Piggyback, New Style, Super Shoda	Standard Piggyback
Shank Sizes	1/16" – 1-1/4" 0.5mm – 34mm	1/64" – 7/32" .2mm – 10mm	1/8" – 1.0" 10mm – 25mm	1/8" – 5/8" 2mm – 16mm	1/8" – 3/4"	22mm, 24mm, 29mm

Aggregate Head	Lubrication		Spindle Output							Applications				
	Grease	Oil Bath	ER25	ER32	ER40	45mm Saw	52mm Saw	Modular	Prolock	Boring	Milling	Sawing	Sanding	
Mono Head	✓	✓	✓	✓	✓	✓	✓	✓	✓	✓	✓	✓	✓	
Duo Head	✓	✓	✓	✓		✓	✓	✓	✓	✓	✓	✓	✓	
Variable Head	✓	✓	✓			✓	✓	✓		✓	✓	✓	✓	
Quattro Head	✓		✓	✓		✓		✓		✓	✓	✓		
Lockset Recess	✓	✓	✓							✓	✓			
Floating Head	✓		✓	✓		✓		✓	✓	✓	✓		✓	
Moulder Head		✓	Moulder Spindle										✓	✓



We stand behind all our products with our 100% Satisfaction Guarantee • www.techniksusa.com

CAT40, CAT50, BT40 Tooling – Package Savings

BT40, 41 pc. Tooling Package



Certified for Accuracy & Balance

List Price: \$2,160.50 – Package Price: \$1,598.00

BT40 tooling package, Order No. TP-B40 - **Save: \$562.50**

Qty.	Part No.	Description	Each	Total
2	16151	BT40 X ER 16-70	\$144.00	\$288.00
4	16177	BT40 X ER 32-70	\$144.00	\$576.00
1	04209IS	ER16 X 10 piece, inch collet set	\$233.50	\$233.50
1	04212IS	ER32 x 18 piece, inch collet set	\$486.00	\$486.00
1	17140-3/8	BT40 x SLN 3/8" - 2-1/2"	\$102.00	\$102.00
1	17140-1/2	BT40 x SLN 1/2" - 2-1/2"	\$102.00	\$102.00
1	17140-5/8	BT40 x SLN 5/8" - 2-1/2"	\$102.00	\$102.00
1	17140-3/4	BT40 x SLN 3/4" - 2-1/2"	\$102.00	\$102.00
1	17140-1	BT40 x SLN 1" - 3-9/16"	\$134.00	\$134.00
1	04609	ER16 - A style wrench	\$14.00	\$14.00
1	04616	ER32 - E style wrench	\$21.00	\$21.00

CAT40, 43 pc. Tooling Package



Certified for Accuracy & Balance

List Price: \$2,435.50 – Package Price: \$1,690.00

CAT40 tooling package, Order No. TP-C40 - **Save: \$745.50**

Qty.	Part No.	Description	Each	Total
2	22225	CAT40 x ER 16 - 2.76"	\$147.00	\$294.00
4	22253	CAT40 x ER 32 - 2.76"	\$158.00	\$632.00
1	04209IS	ER16 x 10 piece, inch collet set	\$233.50	\$233.50
1	04212IS	ER32 x 18 piece, inch collet set	\$486.00	\$486.00
1	22911	CAT40 x SLN 1/4" - 3"	\$85.00	\$85.00
1	22915	CAT40 x SLN 3/8" - 3"	\$85.00	\$85.00
1	22917	CAT40 x SLN 1/2" - 3"	\$85.00	\$85.00
1	22919	CAT40 x SLN 5/8" - 3"	\$85.00	\$85.00
1	22921	CAT40 x SLN 3/4" - 3.5"	\$95.00	\$95.00
1	22925	CAT40 x SLN 1" - 4"	\$95.00	\$95.00
1	22403	CAT40 x SPU 1/2" - 4"	\$235.00	\$235.00
1	04609	ER16 - A style wrench	\$14.00	\$14.00
1	04616	ER32 - E style wrench	\$21.00	\$21.00

CAT50, 45 pc. Tooling Package



List Price: \$3,028.00 – Package Price: \$2,370.00

CAT50 tooling package, Order No. TP-C50 - **Save: \$658.00**

Qty.	Part No.	Description	Each	Total
5	22291	CAT50 x ER 20 - 4	\$185.00	\$925.00
5	22311	CAT50 x ER 32 - 4	\$175.00	\$875.00
1	04210IS	ER20 x 12 piece, inch collet set	\$306.00	\$306.00
1	04212IS	ER32 x 18 piece, inch collet set	\$486.00	\$486.00
2	22945	CAT50 x SLN 1- 4	\$130.00	\$260.00
1	22947	CAT50 x SLN 1-1/4 - 4.6	\$134.00	\$134.00
1	04610	ER20 - A style wrench	\$21.00	\$21.00
1	04616	ER32 - E style wrench	\$21.00	\$21.00

Techniks Certified holders are inspected, tested, and measured for quality, accuracy, and balance. Get a full lab report with each holder.



CAT40 or CAT50 12-Pack Tooling Special!



Score Big Savings on a 12-Pack

Your choice of either CAT40 or CAT50 holders!

1. Select 6 collet chucks & 6 end mill holders (sale priced!)
(Note: you cannot mix CAT40 with CAT50)
2. Choose a complimentary collet set (value up to \$486.00)

CAT40 12 Pack – Order No. 12PACK-C40

Sale Price: \$1,490 - **Save up to \$616.00**

CAT 40 Collet Chucks (choose 6)

Part No.	Description	Each
22225	CAT 40 x ER 16-2.76"	\$143.00
22227	CAT 40 x ER 16-4"	\$143.00
22235	CAT 40 x ER 20-2.76"	\$143.00
22237	CAT 40 x ER 20-4"	\$143.00
22243	CAT 40 x ER 25-2.76"	\$143.00
22245	CAT 40 x ER 25-4"	\$155.00
22253	CAT 40 x ER 32-2.76"	\$153.00
22255	CAT 40 x ER 32-4"	\$153.00
22261	CAT 40 x ER 40-3.15"	\$160.00

CAT40 End Mill Holders (choose 6)

Part No.	Description – d1	Each
22907	CAT 40 x SLN - 1/8"	\$85.00
22909	CAT 40 x SLN - 3/16"	\$85.00
22911	CAT 40 x SLN - 1/4"	\$85.00
22911-1.75	CAT 40 x SLN - 1/4"	\$85.00
22915	CAT 40 x SLN - 3/8"	\$85.00
22915-1.75	CAT 40 x SLN - 3/8"	\$85.00
22917	CAT 40 x SLN - 1/2"	\$85.00
22917-1.75	CAT 40 x SLN - 1/2"	\$85.00
22919	CAT 40 x SLN - 5/8"	\$85.00
22919-1.75	CAT 40 x SLN - 5/8"	\$85.00
22921	CAT 40 x SLN - 3/4"	\$85.00
22921-1.75	CAT 40 x SLN - 3/4"	\$95.00
22925	CAT 40 x SLN - 1"	\$95.00
22925-1.75	CAT 40 x SLN - 1"	\$95.00

ER Inch Collet Sets

Part No.	Desc.	Pcs.	Set Range	Each
04209IS	ER16	10	3/32 – 3/8" by 32 ^{nds}	\$233.50
04210IS	ER20	12	5/32 – 1/2" by 32 ^{nds}	\$306.00
04211IS	ER25	16	5/32 – 5/8" by 32 ^{nds}	\$432.00
04212IS	ER32	18	7/32 – 3/4" by 32 ^{nds}	\$486.00
04213IS	ER40	13	1/8 – 1.0" by 16 ^{ths}	\$390.00

CAT50 12 Pack – Order No. 12PACK-C50

Sale Price: \$1,750 - **Save up to \$716.00**

CAT 50 Collet Chucks (choose 6)

Part No.	Description	Each
22281	CAT 50 x ER 16-4	\$175.00
22291	CAT 50 x ER 20-4	\$180.00
22303	CAT 50 x ER 25-4	\$170.00
22311	CAT 50 x ER 32-4	\$170.00
22321	CAT 50 x ER 40-4	\$180.00

CAT50 End Mill Holders (choose 6)

Part No.	Description – d1	Each
22931	CAT 50 x SLN - 1/4"	\$130.00
22935	CAT 50 x SLN - 3/8"	\$130.00
22937	CAT 50 x SLN - 1/2"	\$130.00
22939	CAT 50 x SLN - 5/8"	\$130.00
22941	CAT 50 x SLN - 3/4"	\$130.00
22945	CAT 50 x SLN - 1"	\$130.00
22947	CAT 50 x SLN - 1 1/4"	\$134.00
22937-6	CAT 50 x SLN - 1/2"	\$150.00
22939-6	CAT 50 x SLN - 5/8"	\$150.00
22941-6	CAT 50 x SLN - 3/4"	\$150.00
22945-6	CAT 50 x SLN - 1"	\$135.00

Choose any Inch or Metric Collet Set **FREE!**

(value up to \$486.00)



ER Metric Collet Sets

Part No.	Desc.	Pcs.	Set Range	Each
04202MS	ER16	10	1 - 10 by 1mm	\$235.00
04203MS	ER20	12	2 - 13 by 1mm	\$321.00
04204MS	ER25	15	2 - 16 by 1mm	\$410.00
04205MS	ER32	18	3 - 20 by 1mm	\$486.00



ISO 20 and BT30 Tooling Packages

10 Piece ISO 20 Tooling Package – Great for Haas* OM1-OM2

Includes: toolholder, PowerCOAT mini-nut, and pull stud



No. TP-ISO20 **Only: \$1,990.00**

Qty.	Part No.	Description	Each	Extended
10	16000-2016MC	ISO20 x ER 16 - 52mm Power Coat Mini Nut and Pull Stud	\$199.00	\$1,990.00



33 Piece BT30 Tooling Package for Haas DT-1



No. TP-DT1 Sale: \$1,250 (original price \$1,536) **Save: \$286.00**

Qty.	Part No.	Description	Each	Extended
1	17130-1/8	BT30-SLN-1/8"	\$80.00	\$80.00
1	17130-1/4	BT30-SLN-1/4"	\$80.00	\$80.00
1	17130-3/8	BT30-SLN-3/8"	\$80.00	\$80.00
1	17130-1/2	BT30-SLN-1/2"	\$80.00	\$80.00
6	16106	BT30-ER20-70mm	\$125.00	\$750.00
1	04210IS	ER20-12 piece collet set	\$306.00	\$306.00
10	07801	BT30-45° Retention Knobs	\$14.00	\$140.00
1	04610	ER20 - A wrench	\$20.00	\$20.00



And choose 5 free,
ER 20 rigid tap collets!

\$200.00 Value

* HAAS is trademark of HAAS Inc. and used here only for identification.

SlimFIT SBL6 Extended Reach Collet System

SlimFIT: Extreme precision, slim design and extended reach.



Features

- Maximum T.I.R. 0.0001" from taper to collet pocket
- Balanced to 25,000 RPM at G2.5
- .55" nose diameters

SlimFIT is the best collet & nut holder solution for cutting tools from 3/32" up to 1/4" when cutting at extended lengths.

12" tapered collet chuck



SlimFIT collets are longer and more powerful than ER collets and provide better accuracy and performance at extended lengths.

Advantages of SlimFIT tool design

The drawbar tightening system eliminates collet nuts, saving time and money. Powerful 4° taper collets provide improved performance holding tool shanks from 3/32" to 1/4" (3mm-6mm). Perform fast tool changes using just the T-wrench.

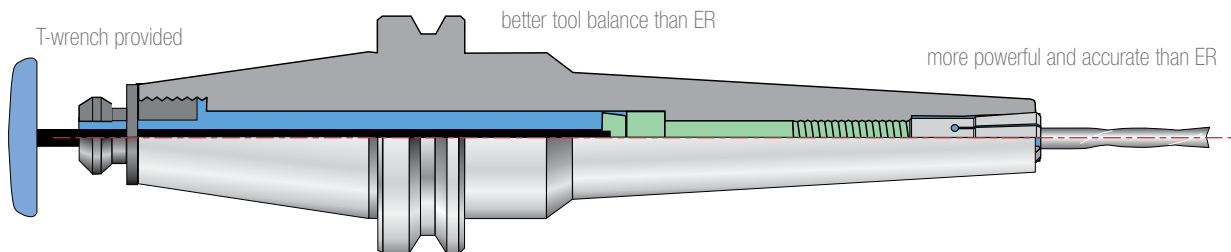

You lose 10% of tool life for every .0001" of T.I.R.
SlimFIT Chucks offer excellent accuracy at extended lengths.

Built for Speed.

All Techniks products are backed by our 100% satisfaction guarantee!



We stand behind all our products with our 100% Satisfaction Guarantee • www.techniksusa.com

CAT40, CAT50 Precision SlimFIT SBL6 Holders



Features

- Maximum T.I.R. 0.0001" from taper to collet pocket
- Balanced to 25,000 RPM at G2.5
- .55" nose diameters



Techniks Certified for accuracy and balance
Each holder comes with a complete lab report

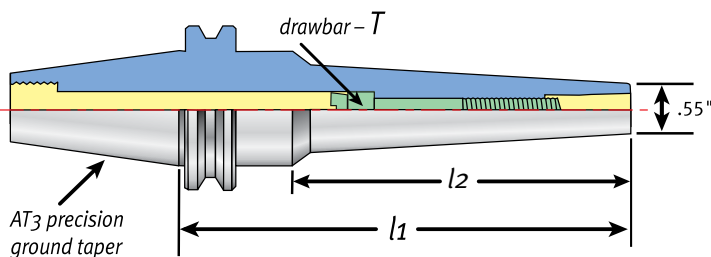

SlimFIT SBL6 holders feature 4° collets and a powerful drawbar tightening system that hold tools tighter and more accurately at extended lengths than ER systems. For tools 3/32" up to 1/4" (3mm-6mm).

Tool changes do not require tightening fixtures, or torque wrenches and can be performance by hand, using the supplied T-wrench.

CAT40, CAT50 SlimFIT Toolholders

Part No.	Description	l1	l2	Drawbar-T
23654	CAT40 x SBL6 - 3" SlimFIT	3"	1.625"	SYIC-SBL-M6C-60
23656	CAT40 x SBL6 - 4" SlimFIT	4"	2.625"	SYIC-SBL-M6C-35
23658	CAT40 x SBL6 - 6" SlimFIT	6"	4.625"	SYIC-SBL-M6C-80
23659	CAT40 x SBL6 - 8" SlimFIT	8"	6.622"	SYIC-SBL-M6C-130
23672	CAT50 x SBL6-3.5" SlimFIT	3.5"	2.12"	SYIC-SBL-M6C-65
23676	CAT50 x SBL6-6" SlimFIT	6"	4.622"	SYIC-SBL-M6C-80

Replacement T20 Wrenches

Part No.	Description
T2050TKIA81F	100mm T-Handle
T20L3TKIA81F	200mm slim shaft fits coolant pull stud



Order SlimFIT 6 collets individually or as a convenient set. See page 20.

Use SlimFIT holders for high-precision machining in tight areas at extended lengths

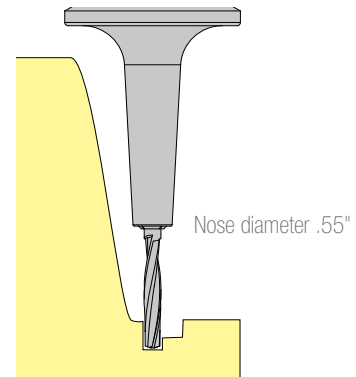

Use a coolant retention knob for coolant thru



BT30, BT40 Precision SlimFIT SBL6 Holders



Features

- Maximum T.I.R. 0.0001" from taper to collet pocket
- Balanced to 25,000 RPM at G2.5
- .55" nose diameters



Techniks Certified for accuracy and balance
Each holder comes with a complete lab report

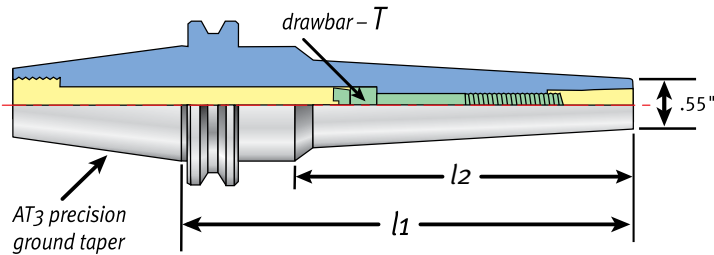

SlimFIT SBL6 holders feature 4° collets and a powerful drawbar tightening system that hold tools tighter and more accurately at extended lengths than ER systems. For tools 3/32" up to 1/4" (3mm-6mm).

Tool changes do not require tightening fixtures, or torque wrenches and can be performed by hand, using the supplied T-wrench.

BT30, BT40 SlimFIT Toolholders

Part No.	Description	l1	l2	Drawbar-T
18854	BT30 x SBL6-70	70mm	48mm	SYIC-SBL-M6C-45
18856	BT30 x SBL6-100	100mm	78mm	SYIC-SBL-M6C-65
18866	BT40 x SBL6-70	70mm	43mm	SYIC-SBL-M6C-45
18868	BT40 x SBL6-100	100mm	73mm	SYIC-SBL-M6C-80
18868-150	BT40 x SBL6-150	150mm	123mm	SYIC-SBL-M6C-65
18869	BT40 x SBL6-200	200mm	173mm	SYIC-SBL-M6C-130

Replacement T20 Wrenches

Part No.	Description
T2050TKIA81F	100mm T-Handle
T20L3TKIA81F	200mm slim shaft fits coolant pull stud



Order SlimFIT 6 collets individually or as a convenient set. See page 20.

Use SlimFIT holders for high-precision machining in tight areas at extended lengths

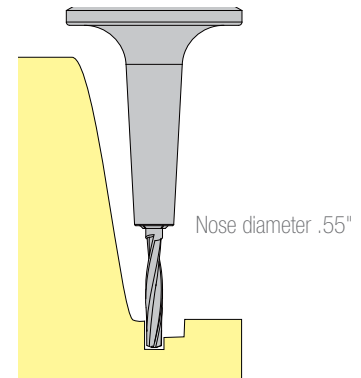

Use a coolant retention knob for coolant thru



HSK63A Precision SlimFIT SBL6 Holders



Features

- Maximum T.I.R. 0.0001" from taper to collet pocket
- Balanced to 25,000 RPM at G2.5
- .55" nose diameters



Techniks Certified for accuracy and balance
Each holder comes with a complete lab report

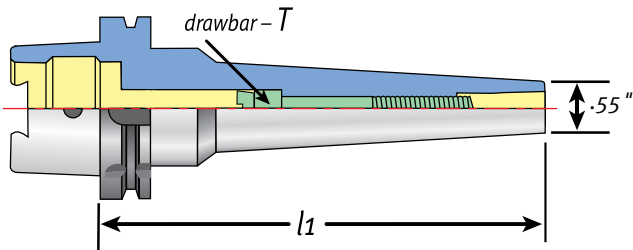

SlimFIT SBL6 holders feature 4° collets and a powerful drawbar tightening system that hold tools tighter and more accurately at extended lengths than ER systems. For tools 3/32" up to 1/4" (3mm-6mm).

Tool changes do not require tightening fixtures, or torque wrenches and can be performed by hand, using the supplied T-wrench.

HSK63A SlimFIT Toolholders

Part No.	Description	l1	l2	Drawbar-T
35470	HSK63A x SBL6-80 SlimFIT	80mm	54mm	SYIC-SBL-M6C-15
35472	HSK63A x SBL6-120 SlimFIT	120mm	94mm	SYIC-SBL-M6C-50

Replacement T20 Wrenches

Part No.	Description
T2050TKIA81F	100mm T-Handle
T20L3TKIA81F	200mm slim shaft fits coolant pull stud



Order SlimFIT 6 collets individually or as a convenient set. See page 20.

Use SlimFIT holders for high-precision machining in tight areas at extended lengths

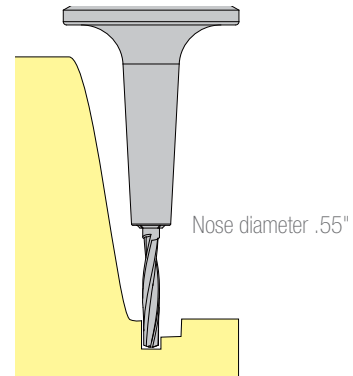

Use a coolant retention knob for coolant thru



SlimFIT High-Precision Extensions

Extensions turn any 1/2" or 5/8" holder into a SlimFIT tool!



Features

- Use with any 1/2" or 5/8" toolholder –even end mill holders
- 4° angle drawbar collet for greater holding power and accuracy
- Only .48" nose diameter!

Extensions feature a nose clearance of .48" which allows machining where other tools cannot reach.



Use a coolant retention knob for coolant thru



Use SlimFIT extensions with cutting tools from 3/32" up to 1/4" (3-6mm) shank sizes. Internal drawbar collet eliminates collet nut to permit narrow nose diameter.

Tool changes do not require tightening fixtures, or torque wrenches and can be performance by hand, using the supplied T-wrench.

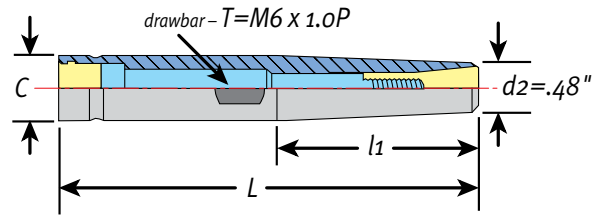

SlimFIT Extensions Fit 1/2" or 5/8" Toolholders

Part No.	Description	L	l1	C
06032-3	1/2" x OLP6-3" extension	3"	1.89"	.50"
06032	1/2" x OLP6-5" extension	5"	1.89"	.50"
06034	1/2" x OLP6-6" extension	6"	1.89"	.50"
06038	5/8" x OLP6-5" extension	5"	1.89"	.625"
06040	5/8" x OLP6-6" extension	6"	1.89"	.625"
06042	5/8" x OLP6-8" extension	8"	1.89"	.625"

Replacement T20 Wrenches

Part No.	Description
T2050TKIA81F	100mm T-Handle
T20L3TKIA81F	200mm slim shaft fits coolant pull stud



Order SlimFIT 6 collets individually or as a convenient set. See page 20.

High-Performance SlimFIT Collets



Features

- Made from high-carbon steel and heat-treated for long life
- Precision ground and polished
- Each collet individually inspected for quality

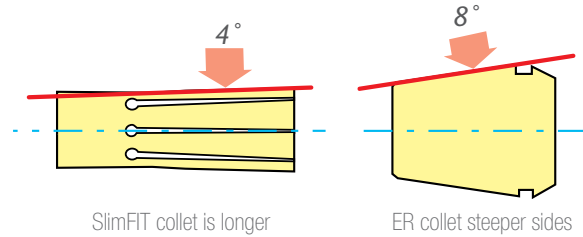

Why SlimFIT out-performs ER Collet systems

SlimFIT collets are longer overall than ER collets and feature a 4° taper, so there is more engagement with the tool shank and the drawbar clamping holds more securely than ER. Also the holder assembly is better balanced than ER since there is no collet nut needed.

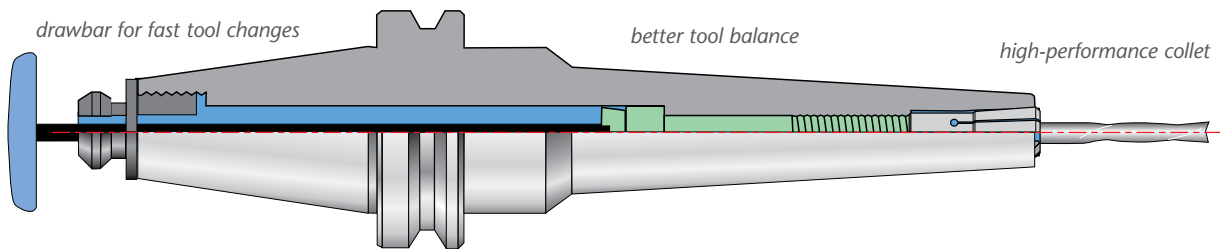

SlimFIT Inch Collets

Part No.	Description
18851-3/32	SlimFIT 6 - 3/32" collet
18851-7/64	SlimFIT 6 - 7/64" collet
18851-1/8	SlimFIT 6 - 1/8" collet
18851-9/64	SlimFIT 6 - 9/64" collet
18851-5/32	SlimFIT 6 - 5/32" collet
18851-11/64	SlimFIT 6 - 11/64" collet
18851-3/16	SlimFIT 6 - 3/16" collet
18851-13/64	SlimFIT 6 - 13/64" collet
18851-7/32	SlimFIT 6 - 7/32" collet
18851-15/64	SlimFIT 6 - 15/64" collet
18851-1/4	SlimFIT 6 - 1/4" collet

SlimFIT Inch & Metric Set

Part No.	Description
18851-12IMS	SlimFIT 12 piece set

Convenient collet set provides the collets you need, and the wooden tray prevents damage to collets.

Set includes 12 collets.

INCH: 7/64", 1/8", 9/64", 11/64", 3/16", 13/64", 15/64", 1/4"

METRIC: 3mm, 4mm, 5mm, 6mm and wooden tray.

SlimFIT Metric Collets

Part No.	Description
18851-03	SlimFIT 6 - 3mm collet
18851-04	SlimFIT 6 - 4mm collet
18851-05	SlimFIT 6 - 5mm collet
18851-05.5	SlimFIT 6 - 5.5mm collet
18851-06	SlimFIT 6 - 6mm collet

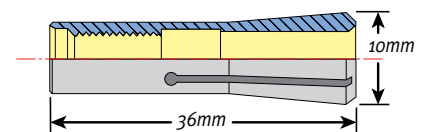

SlimFIT Collet Dimensions

NOTE: Tighten to 9 ft/lbs

Techniks Certified ER Collet & Nut Toolholders

Balanced to 25,000 RPM

Factory balanced to 25,000 RPM at G2.5
Custom balancing to 60,000 RPM available.



Ultra Precision Collet

Each collet hand inspected.
T.I.R. only 0.0002"



Taper Accuracy AT3

Taper ground to AT3 accuracy for maximum contact with spindle.

Taper-to-Pocket T.I.R. 0.0001"

Measured from taper O.D. to collet pocket I.D.

Lab Certified Accuracy

Each toolholder is lab certified for accuracy and balance.

Inch and Metric Sizes



Sealed



Steel Sealed



T.I.R. 0.0002"



Quick-Change Tap



Floating Tap



Rigid Tap



PowerCOAT Nuts

Our PowerCOAT nut holds 75% tighter than standard nuts for best T.I.R. and rigidity.



Balanced Nut

Balanced nut reduces vibration at high speeds to extend cutting tool life.



<http://ow.ly/rigp6>
View the video



Techniks Certified Tooling means the critical features of each holder has been individually lab tested, measured and inspected for quality. Depending on the holder this can include: balance, dimensional accuracy, collet pocket runout (T.I.R.), bore I.D. and taper accuracy.

You lose 10% of tool life for every .0001" of T.I.R.
Techniks collets & nut toolholders extend cutting tool life.

Built for Speed.



All Techniks products are backed by our 100% satisfaction guarantee!



We stand behind all our products with our 100% Satisfaction Guarantee • www.techniksusa.com

CAT40 Precision ER Toolholders



Techniks Certified for accuracy and balance
Each holder comes with a complete lab report

For shank sizes 1/8" (3mm) or smaller use our DNA (dead nuts accurate) collet results.

See page 54.

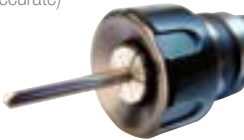

Features

- *Balanced to 25,000 RPM at G2.5*
- *T.I.R. 0.0001" measured from taper to collet pocket*
- *PowerCOAT nut included for 75% more clamping power*

For ER16 and 20 slotted nuts, add SLOTNUT to the end of the part number. For holders with coolant nut included add -C to the end of the part number. Coolant nuts are not available for ER50.



Collets
pg. 49



Nuts
pg. 64



Coolant
Rings
pg. 66



Retention
Knobs
pg. 228



Wrenches
pg. 232



Tightening
Stands
pg. 234

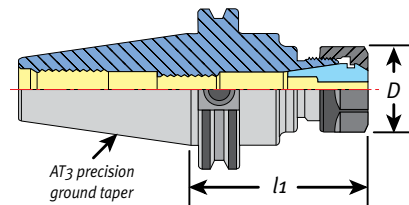

CAT40 ER Toolholders

Part No.	Description	l1	D	Max. Shank	Set Screw	Wrench
22213-3	CAT40 x ER11 - 3", hex nut	3"	.748"	.275"	16081	04608
22225	CAT40 x ER16 - 2.76", hex nut	2.76"	1.08"	.406"	16083	04609
22227	CAT40 x ER16 - 4", hex nut	4"	1.08"	.406"	16083	04609
22231	CAT40 x ER16 - 6", hex nut	6"	1.08"	.406"	16083	04609
22233	CAT40 x ER16 - 8", hex nut	8"	1.08"	.406"	16083	04609
NEW 22233-10	CAT40 x ER16 - 10", hex nut	10"	1.08"	.406"	16083	04609
22235	CAT40 x ER20 - 2.76", hex nut	2.76"	1.34"	.512"	16087	04610
22237	CAT40 x ER20 - 4", hex nut	4"	1.34"	.512"	16087	04610
22239	CAT40 x ER20 - 6", hex nut	6"	1.34"	.512"	16087	04610
NEW 22239-10	CAT40 x ER20 - 10", hex nut	10"	1.34"	.512"	16087	04610
22243-2.5	CAT40 x ER25 - 2.5", slotted nut	2.5"	1.65"	.630"	16089	04615
22243	CAT40 x ER25 - 2.76", slotted nut	2.76"	1.65"	.630"	16089	04615
22245	CAT40 x ER25 - 4", slotted nut	4"	1.65"	.630"	16089	04615
22247	CAT40 x ER25 - 6", slotted nut	6"	1.65"	.630"	16089	04615
22251	CAT40 x ER25 - 8", slotted nut	8"	1.65"	.630"	16089	04615
22253	CAT40 x ER32 - 2.76", slotted nut	2.76"	1.97"	.788"	16089	04616
22255	CAT40 x ER32 - 4", slotted nut	4"	1.97"	.788"	16089	04616
22257	CAT40 x ER32 - 6", slotted nut	6"	1.97"	.788"	16089	04616
22259	CAT40 x ER32 - 8", slotted nut	8"	1.97"	.788"	16089	04616
NEW 22259-10	CAT40 x ER32 - 10", slotted nut	10"	1.97"	.788"	16089	04616
22261	CAT40 x ER40 - 3.15", slotted nut	3.15"	2.48"	1.023"	16091	04617
22263	CAT40 x ER40 - 4", slotted nut	4"	2.48"	1.023"	16091	04617
22265	CAT40 x ER40 - 6", slotted nut	6"	2.48"	1.023"	16091	04617
22269	CAT40 x ER50 - 4", slotted nut	4"	3.07"	1.338"	16093	04618

CAT40 Precision CoolFLEX ER Toolholders



Techniks Certified for accuracy and balance
Each holder comes with a complete lab report

Features

- Coolant-thru spindle or thru flange (DIN B)
- Balanced to 25,000 RPM at G2.5
- T.I.R. 0.0001" or better from taper to collet pocket

For ER16 and 20 slotted nuts, add SLOTNUT to the end of the part number. For holders with coolant nut included add -C to the end of the part number. Coolant nuts are not available for ER50.

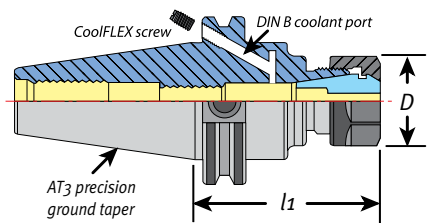

CoolFLEX Feature

CoolFLEX holders are factory set for coolant-thru spindle. Simply remove 2 stop screws for DIN B coolant-thru flange.

Part No. Description

HSA-4-6	40 taper DIN B screw
---------	----------------------

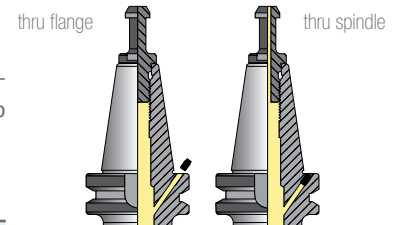

Coolant Set Screws page 47.

CAT40 CoolFLEX Coolant-Thru Spindle or Flange (DIN B)

Part No.	Description	l1	D	Max. Shank	Set Screw	Wrench
22225F	CAT40 x ER16 - 2.76", hex nut	2.76"	1.08"	.406"	16083	04609
22227F	CAT40 x ER16 - 4", hex nut	4"	1.08"	.406"	16083	04609
22231F	CAT40 x ER16 - 6", hex nut	6"	1.08"	.406"	16083	04609
22233F	CAT40 x ER16 - 8", hex nut	8"	1.08"	.406"	16083	04609
22235F	CAT40 x ER20 - 2.76", hex nut	2.76"	1.34"	.512"	16087	04610
22237F	CAT40 x ER20 - 4", hex nut	4"	1.34"	.512"	16087	04610
22239F	CAT40 x ER20 - 6", hex nut	6"	1.34"	.512"	16087	04610
22243F	CAT40 x ER25 - 2.76", slotted nut	2.76"	1.65"	.630"	16089	04615
22245F	CAT40 x ER25 - 4", slotted nut	4"	1.65"	.630"	16089	04615
22247F	CAT40 x ER25 - 6", slotted nut	6"	1.65"	.630"	16089	04615
22251F	CAT40 x ER25 - 8", slotted nut	8"	1.65"	.630"	16089	04615
22253F	CAT40 x ER32 - 2.76", slotted nut	2.76"	1.97"	.788"	16089	04616
22255F	CAT40 x ER32 - 4", slotted nut	4"	1.97"	.788"	16089	04616
22257F	CAT40 x ER32 - 6", slotted nut	6"	1.97"	.788"	16089	04616
22259F	CAT40 x ER32 - 8", slotted nut	8"	1.97"	.788"	16089	04616
22261F	CAT40 x ER40 - 3.15", slotted nut	3.15"	2.48"	1.023"	16091	04617
22263F	CAT40 x ER40 - 4", slotted nut	4"	2.48"	1.023"	16091	04617

Blue indicates coolant.



CAT40 Precision ER Mini Nut Holders



Techniks Certified for accuracy and balance.
Each holder comes with a complete lab report

Features

- *Narrow nut diameter for better clearance*
- *Balanced to 25,000 RPM at G2.5*
- *T.I.R. 0.0001" measured from taper to collet pocket*



Collets
pg. 49



Nuts
pg. 64



Coolant
Rings
pg. 66



Retention
Knobs
pg. 228



Wrenches
pg. 232



Tightening
Stands
pg. 234



Coolant Options

- *ER coolant rings (pg. 66)*
- *ER Steel Sealed collets (pg. 56)*
- *ER Sealed coolant collets (pg. 58)*

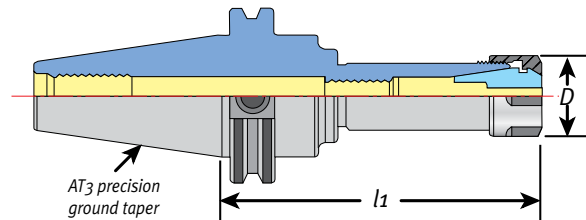

CAT40 ER Mini Nut Holders

Coolant Set Screws page 47.

Part No.	Description	l1	D	Max. Shank	Set Screw	Wrench
22352	CAT40 x ER11 - 2.75", mini nut	2.75"	.63"	.275"	16081	04621
22354	CAT40 x ER11 - 4", mini nut	4"	.63"	.275"	16081	04621
22354-6	CAT40 x ER11 - 6", mini nut	6"	.63"	.275"	16081	04621
22354-8.5	CAT40 x ER11 - 8.5", mini nut	8.5"	.63"	.275"	16081	04621
22356	CAT40 x ER16 - 2.76", mini nut	2.76"	.87"	.406"	16083	04622
22358	CAT40 x ER16 - 4", mini nut	4"	.87"	.406"	16083	04622
22359	CAT40 x ER16 - 6", mini nut	6"	.87"	.406"	16083	04622
22359-8	CAT40 x ER16 - 8", mini nut	8"	.87"	.406"	16083	04622
22360	CAT40 x ER20 - 2.76", mini nut	2.76"	1.102"	.512"	16087	04623
22362	CAT40 x ER20 - 4", mini nut	4"	1.102"	.512"	16087	04623

CAT40 Precision SuperRIGID Holders



Techniks Certified for accuracy and balance
 Each holder comes with a complete lab report
 Collet nut is included with each holder

Features

- *Balanced to 25,000 RPM at G2.5*
- *Best T.I.R. and Z axis of any collet chuck*
- *SuperRIGID for high torque or high speed machining*



Use SuperRIGID holders with ER32 collets.

SuperRIGID Holders

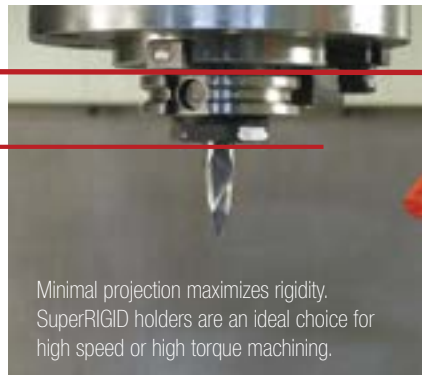

minimum projection

Minimal projection maximizes rigidity. SuperRIGID holders are an ideal choice for high speed or high torque machining.

Standard Holders

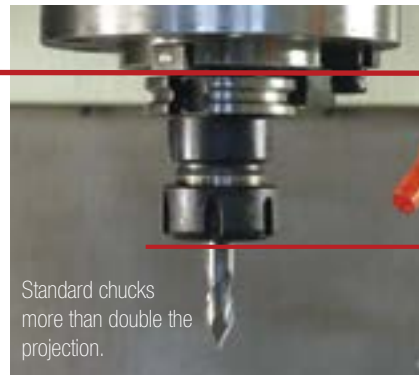

standard projection

Standard chucks more than double the projection.

Minimum projection = increased rigidity, better T.I.R. and extended cutter life.

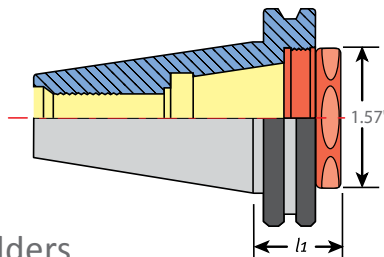

PowerCOAT
TE-22HN Nut

CAT40 SuperRIGID ER Toolholders

Part No.	Description	l1	Collet	Max. Shank	Wrench
22253S	CAT40 x ER32	1.10"	ER32	3/4" or 20mm	894-36
TE-22HN	hex style PowerCOAT replacement nut				



CAT40 DualDRIVE for Dual-Contact Spindles



Techniks Certified for accuracy and balance
Each holder comes with a complete lab report

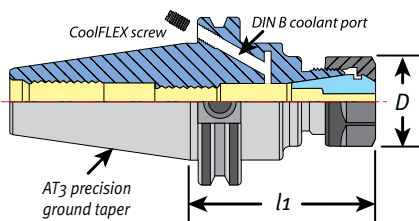

Features

- New one-piece design for dual-contact spindles
- Coolant-thru spindle or thru flange (DIN B)
- Balanced to 25,000 RPM at G2.5

Benefits

- Better rigidity and reduced vibration
- Improved performance at high metal removal rates and when machining at extended lengths

CoolFLEX Feature

CoolFLEX holders are factory set for coolant-thru spindle. Simply remove 2 stop screws for DIN B coolant-thru flange.

thru flange thru spindle

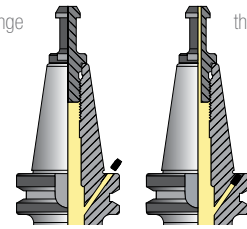

Coolant Set Screws page 47.

Part No. Description

HSA-4-6 40 taper DIN B screw

CAT40 DualDRIVE Coolant-Thru Spindle or Flange (DIN B)

Part No.	Description - L1	L1	D	Collet	Max. Shank	Set Screw	Wrench
46.122.16.276	CAT40 x ER16 -2.76" DualDRIVE	2.76"	1.08"	ER16	.406"	16083	04609
46.122.16.400	CAT40 x ER16 - 4" DualDRIVE	4"	1.08"	ER16	.406"	16083	04609
46.122.16.600	CAT40 x ER16 - 6" DualDRIVE	6"	1.08"	ER16	.406"	16083	04609
46.122.16.800	CAT40 x ER16 - 8" DualDRIVE	8"	1.08"	ER16	.406"	16083	04609
NEW 46.122.20.276	CAT40 x ER20 -2.76" DualDRIVE	2.76"	1.34"	ER20	.512"	16087	14610
NEW 46.122.20.400	CAT40 x ER20 - 4" DualDRIVE	4"	1.34"	ER20	.512"	16087	14610
NEW 46.122.20.600	CAT40 x ER20 - 6" DualDRIVE	6"	1.34"	ER20	.512"	16087	14610
NEW 46.122.20.800	CAT40 x ER20 - 8" DualDRIVE	8"	1.34"	ER20	.512"	16087	14610
46.122.32.276	CAT40 x ER32 - 2.76" DualDRIVE	2.76"	1.97"	ER32	.788"	16089	04616
46.122.32.400	CAT40 x ER32 - 4" DualDRIVE	4"	1.97"	ER32	.788"	16089	04616
46.122.32.600	CAT40 x ER32 - 6" DualDRIVE	6"	1.97"	ER32	.788"	16089	04616
NEW 46.122.32.800	CAT40 x ER32 - 8" DualDRIVE	8"	1.97"	ER32	.788"	16089	04616
46.122.40.315	CAT40 x ER40 - 3.15" DualDRIVE	3.15"	2.48"	ER40	1.023"	16091	04617
NEW 46.122.40.600	CAT40 x ER40 - 6" DualDRIVE	6"	2.48"	ER40	1.023"	16091	04617
NEW 46.122.40.800	CAT40 x ER40 - 8" DualDRIVE	8"	2.48"	ER40	1.023"	16091	04617

Blue indicates coolant.

Dual-Contact Spindles

Use Techniks DualDRIVE holders if your machine has a dual-contact spindle. Dual-Contact is a spindle option offered by some machine tool builders.

Dual-contact means both the toolholder taper and the flange make contact with the spindle. Dual-contact increases rigidity and accuracy during machining.

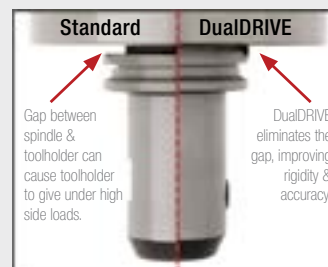

Gap between spindle & toolholder can cause toolholder to give under high side loads.

DualDRIVE eliminates the gap, improving rigidity & accuracy.



See our demonstration video of DualDRIVE at:
<http://ow.ly/sUOqL>

CAT50 Precision ER Toolholders



Techniks Certified for accuracy and balance
Each holder comes with a complete lab report

Features

- *Balanced to 25,000 RPM at G2.5*
- *T.I.R. 0.0001" measured from taper to collet pocket*
- *PowerCOAT nut included for 75% more clamping power*

For ER16 and 20 slotted nuts, add SLOTNUT to the end of the part number. For holders with coolant nut included add -C to the end of the part number. Coolant nuts are not available for ER50.

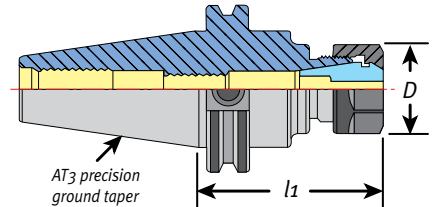

CAT50 ER Toolholders

Part No.	Description	l1	D	Max. Shank	Set Screw	Wrench
22281	CAT50 x ER16 - 4", hex nut	4"	1.08"	.406"	16083	04609
22285	CAT50 x ER16 - 6", hex nut	6"	1.08"	.406"	16083	04609
22287	CAT50 x ER16 - 8", hex nut	8"	1.08"	.406"	16083	04609
22291	CAT50 x ER20 - 4", hex nut	4"	1.34"	.512"	16087	04610
22293	CAT50 x ER20 - 6", hex nut	6"	1.34"	.512"	16087	04610
22295	CAT50 x ER20 - 8", hex nut	8"	1.34"	.512"	16087	04610
22303	CAT50 x ER25 - 4", slotted nut	4"	1.65"	.630"	16089	04615
22305	CAT50 x ER25 - 6", slotted nut	6"	1.65"	.630"	16089	04615
22307	CAT50 x ER25 - 8", slotted nut	8"	1.65"	.630"	16089	04615
22307-9	CAT50 x ER25 - 9", slotted nut	9"	1.65"	.630"	16089	04615
22311	CAT50 x ER32 - 4", slotted nut	4"	1.97"	.788"	16089	04616
22313	CAT50 x ER32 - 6", slotted nut	6"	1.97"	.788"	16089	04616
22317	CAT50 x ER32 - 8", slotted nut	8"	1.97"	.788"	16089	04616
22321	CAT50 x ER40 - 4", slotted nut	4"	2.48"	1.023"	16091	04617
22325	CAT50 x ER40 - 6", slotted nut	6"	2.48"	1.023"	16091	04617
22327	CAT50 x ER40 - 8", slotted nut	8"	2.48"	1.023"	16091	04617
22331	CAT50 x ER50 - 4", slotted nut	4"	3.07"	1.338"	16093	04618
22335	CAT50 x ER50 - 6", slotted nut	6"	3.07"	1.338"	16093	04618
22337	CAT50 x ER50 - 8", slotted nut	8"	3.07"	1.338"	16093	04618

Coolant Set Screws page 47.

CAT50 ER Tapered Style Toolholders (taper improves rigidity at extended lengths)

Part No.	Description	l1	D	Max. Shank	Set Screw	Wrench
NEW 22287-10T	CAT50 x ER16 - 10", hex nut	10"	1.08"	.406"	16083	04609
NEW 22287-12T	CAT50 x ER16 - 12", hex nut	12"	1.08"	.406"	16083	04609
NEW 22295-10T	CAT50 x ER20 - 10", hex nut	10"	1.34"	.512"	16087	04610
NEW 22295-12T	CAT50 x ER20 - 12", hex nut	12"	1.34"	.512"	16087	04610
NEW 22317-10T	CAT50 x ER32 - 10", slotted nut	10"	1.97"	.788"	16089	04616
NEW 22317-12T	CAT50 x ER32 - 12", slotted nut	12"	1.97"	.788"	16089	04616
NEW 22327-10T	CAT50 x ER40 - 10", slotted nut	10"	2.48"	1.023"	16091	04617



We stand behind all our products with our 100% Satisfaction Guarantee • www.techniksusa.com

CAT50 Precision CoolFLEX Toolholders



A PowerCOAT mini nut is included with each holder. Techniks Certified for accuracy and balance. Each holder comes with a complete lab report.

Features

- Coolant-thru spindle or thru flange (DIN B)
- Balanced to 25,000 RPM at G2.5
- T.I.R. 0.0001" or better from taper to collet pocket

For ER16 and 20 slotted nuts, add SLOTNUT to the end of the part number. For holders with coolant nut included add -C to the end of the part number. Coolant nuts are not available for ER50.



Collets
pg. 49



Nuts
pg. 64



Coolant
Rings
pg. 66



Retention
Knobs
pg. 228



Wrenches
pg. 232



Tightening
Stands
pg. 234

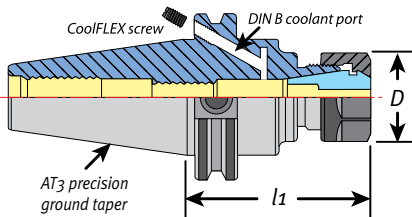

CoolFLEX Feature

CoolFLEX holders are factory set for coolant-thru spindle. Simply remove 2 stop screws for DIN B coolant-thru flange.

Part No.	Description
HSA-4-6	40 taper DIN B screw

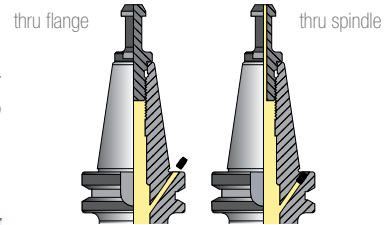

Coolant Set Screws page 47.

CAT50 CoolFLEX Coolant-Thru Spindle or Flange (DIN B)

Part No.	Description	l1	D	Max. Shank	Set Screw	Wrench
22281F	CAT50 x ER16 - 4", hex nut	4"	1.08"	.406"	16083	04609
22285F	CAT50 x ER16 - 6", hex nut	6"	1.08"	.406"	16083	04609
22291F	CAT50 x ER20 - 4", hex nut	4"	1.34"	.512"	16087	04610
22293F	CAT50 x ER20 - 6", hex nut	6"	1.34"	.512"	16087	04610
22295F	CAT50 x ER20 - 8", hex nut	8"	1.34"	.512"	16087	04610
22303F	CAT50 x ER25 - 4", slotted nut	4"	1.65"	.630"	16089	04615
22311F	CAT50 x ER32 - 4", slotted nut	4"	1.97"	.788"	16089	04616
22313F	CAT50 x ER32 - 6", slotted nut	6"	1.97"	.788"	16089	04616
22317F	CAT50 x ER32 - 8", slotted nut	8"	1.97"	.788"	16089	04616
22321F	CAT50 x ER40 - 4", slotted nut	4"	2.48"	1.023"	16091	04617
22327F	CAT50 x ER40 - 8", slotted nut	8"	2.48"	1.023"	16091	04617

Blue indicates coolant.

CAT50 Precision ER Mini Nut Holders



Features

- *Narrow nut diameter for better clearance*
- *Balanced to 25,000 RPM at G2.5*
- *T.I.R. 0.0001" measured from taper to collet pocket*



Collets
pg. 49



Nuts
pg. 64



Coolant
Rings
pg. 66



Retention
Knobs
pg. 228



Wrenches
pg. 232



Tightening
Stands
pg. 234

A PowerCOAT mini nut is included with each holder.
Techniks Certified for accuracy and balance.
Each holder comes with a complete lab report.



Coolant Options

- *ER coolant rings (pg. 66)*
- *ER Steel Sealed collets (pg. 56)*
- *ER Sealed coolant collets (pg. 58)*

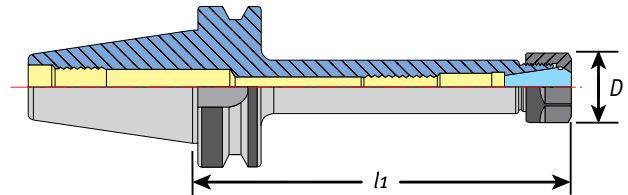

Coolant Set Screws page 47.

CAT50 ER Mini Nut Holders

Part No.	Description	l1	D	Max. Shank	Set Screw	Wrench
22364	CAT50 x ER16 - 4", mini nut	4"	.87"	.406"	16083	04622
22366	CAT50 x ER16 - 6", mini nut	6"	.87"	.406"	16083	04622
22368	CAT50 x ER20 - 4", mini nut	4"	1.102"	.512"	16087	04623
22370	CAT50 x ER20 - 6", mini nut	6"	1.102"	.512"	16087	04623

CAT50 Precision ER32 SuperRIGID Holders



Techniks Certified for accuracy and balance.
Each holder comes with a complete lab report.
Collet nut is included with each holder.

Features

- *Balanced to 25,000 RPM at G2.5*
- *Best T.I.R. and Z axis of any collet chuck*
- *SuperRIGID for high torque or high speed machining*



Use SuperRIGID holders with ER32 collets.

SuperRIGID Holders



Standard Holders

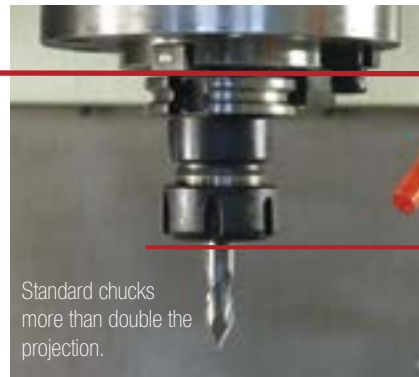

Minimum projection = increased rigidity, better T.I.R. and extended cutter life.

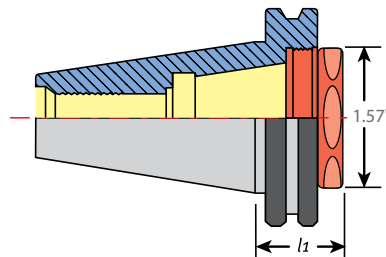

PowerCOAT
TE-22HN Nut

CAT50 SuperRIGID ER Toolholders

Part No.	Description	l1	Collet	Max. Shank	Wrench
22311S	CAT50 x ER32	1.10"	ER32	3/4" or 20mm	894-36
TE-22HN	hex style PowerCOAT nut				

CAT50 DualDRIVE for Dual-Contact Spindles



PowerCOAT nut is included with each holder
 Techniks Certified for accuracy and balance
 Each holder comes with a complete lab report

Features

- New one-piece design for dual-contact spindles
- Coolant-thru spindle or thru flange (DIN B)
- Balanced to 25,000 RPM at G2.5

Benefits

- Better rigidity and reduced vibration
- Improved performance at high metal removal rates and when machining at extended lengths

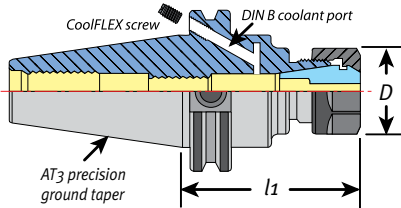

CoolFLEX Feature

CoolFLEX holders are factory set for coolant-thru spindle. Simply remove 2 stop screws for DIN B coolant-thru flange.

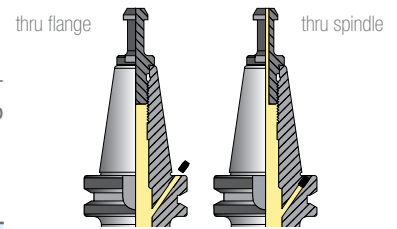

Coolant Set Screws page 47.

Part No.	Description
HSA-4-6	40 taper DIN B screw

CAT50 ER DualDRIVE Coolant-Thru Spindle or Flange (DIN B)

Part No.	Description - l1	l1	D	Collet	Max. Shank	Set Screw	Wrench
47.122.16.400	CAT50 x ER16 - 4" DualDRIVE	4"	1.08"	ER16	.406"	16083	04609
47.122.16.600	CAT50 x ER16 - 6" DualDRIVE	6"	1.08"	ER16	.406"	16083	04609
47.122.16.800	CAT50 x ER16 - 8" DualDRIVE	8"	1.08"	ER16	.406"	16083	04609
NEW 47.122.20.400	CAT50 x ER20 - 4" DualDRIVE	4"	1.34"	.512"	16087	04610	
NEW 47.122.20.600	CAT50 x ER20 - 6" DualDRIVE	6"	1.34"	.512"	16087	04610	
NEW 47.122.20.800	CAT50 x ER20 - 8" DualDRIVE	8"	1.34"	.512"	16087	04610	
47.122.32.400	CAT50 x ER32 - 4" DualDRIVE	4"	1.97"	ER32	.788"	16089	04616
47.122.32.600	CAT50 x ER32 - 6" DualDRIVE	6"	1.97"	ER32	.788"	16089	04616
47.122.32.800	CAT50 x ER32 - 8" DualDRIVE	8"	1.97"	ER32	.788"	16089	04616
47.122.40.400	CAT50 x ER40 - 4" DualDRIVE	4"	2.48"	ER40	1.023"	16091	04617
NEW 47.122.40.600	CAT50 x ER40 - 6" DualDRIVE	6"	2.48"	1.023"	16091	04617	
NEW 47.122.40.800	CAT50 x ER40 - 8" DualDRIVE	8"	2.48"	1.023"	16091	04617	

Blue indicates coolant.

Dual-Contact Spindles

Use Techniks DualDRIVE holders if your machine has a dual-contact spindle. Dual-Contact is a spindle option offered by some machine tool builders.

Dual-contact means both the toolholder taper and the flange make contact with the spindle. Dual-contact increases rigidity and accuracy during machining.

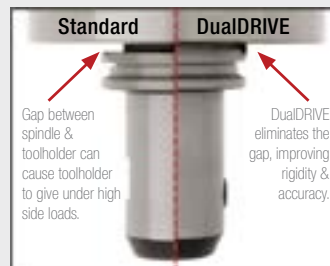

See our demonstration video of DualDRIVE at:
<http://ow.ly/sUOqL>



BT30 Precision ER Toolholders & Mini Nut Holders



Techniks Certified for accuracy and balance
Each holder comes with a complete lab report

BT30 Features

- *Balanced to 25,000 RPM at G2.5*
- *T.I.R. 0.0001" measured from taper to collet pocket*
- *Taper ground to AT3 accuracy or better*

For ER16 and 20 slotted nuts, add SLOTNUT to the end of the part number. For holders with coolant nut included add -C to the end of the part number. Coolant nuts are not available for ER50.

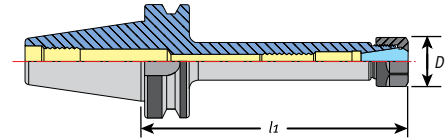

BT30 Precision ER Toolholders

Part No.	Description	L1	D	Max. Shank	Set Screw	Wrench
16102	BT30 x ER16 - 60mm, hex nut	60mm	1.08"	.406"	16083	04609
16101	BT30 x ER16 - 70mm, hex nut	70mm	1.08"	.406"	16083	04609
16103	BT30 x ER16 - 90mm, hex nut	90mm	1.08"	.406"	16083	04609
16104	BT30 x ER16 - 100mm, hex nut	100mm	1.08"	.406"	16083	04609
16105	BT30 x ER16 - 120mm, hex nut	120mm	1.08"	.406"	16083	04609
16106	BT30 x ER20 - 70mm, hex nut	70mm	1.34"	.512"	16087	04610
16107	BT30 x ER20 - 135mm, hex nut	135mm	1.34"	.512"	16087	04610
16108-2.5	BT30 x ER20 - 63.5mm, hex nut	63.5mm	1.34"	.512"	16087	04610
16109	BT30 x ER25 - 70mm, slotted nut	70mm	1.65"	.63"	16089	04615
16110	BT30 x ER25 - 60mm, slotted nut	60mm	1.65"	.63"	16089	04615
16111-90	BT30 x ER25 - 90mm, slotted nut	90mm	1.65"	.63"	16089	04615
16111	BT30 x ER25 - 135mm, slotted nut	135mm	1.65"	.63"	16089	04615
16112	BT30 x ER32 - 60mm, slotted nut	60mm	1.97"	.788"	16089	04616
16113	BT30 x ER32 - 70mm, slotted nut	70mm	1.97"	.788"	16089	04616
16114	BT30 x ER32 - 100mm, slotted nut	100mm	1.97"	.788"	16089	04616
16115	BT30 x ER40 - 80mm, slotted nut	80mm	2.48"	1.023"	16089	04617



BT30 Precision ER Mini Nut Holders

BT Mini Nut Features

- *Narrow nut diameter for better clearance*
- *Balanced to 25,000 RPM at G2.5*
- *T.I.R. 0.0001" measured from taper to collet pocket*

For coolant applications use ER16 or ER20 coolant mini nut (pg. 65)
Coolant Set Screws page 47.

Part No.	Description	L1	D	Max. Shank	Set Screw	Wrench
16302	BT30 x ER11 - 70mm, mini nut	70	.63"	.275"	16081	04621
16304	BT30 x ER11 - 100mm, mini nut	100mm	.63"	.275"	16081	04621
16308	BT30 x ER16 - 70mm, mini nut	70mm	.87"	.406"	16083	04622
16312	BT30 x ER16 - 120mm, mini nut	120mm	.87"	.406"	16083	04622
16313	BT30 x ER20 - 70mm, mini nut	70mm	1.102"	.512"	16087	04623
16314	BT30 x ER20 - 100mm, mini nut	100mm	1.102"	.512"	16087	04623
16318	BT30 x ER20 - 150mm, mini nut	150mm	1.102"	.512"	16087	04623

BT30 DualDRIVE for Dual-Contact Spindles



PowerCOAT nut is included with each holder
Techniks Certified for accuracy and balance
Each holder comes with a complete lab report

Features

- New one-piece design for dual-contact spindles
- Improves rigidity and reduces vibration
- Balanced to 25,000 RPM at G2.5

Benefits

- Better rigidity and reduced vibration
- Improved performance at high metal removal rates and when machining at extended lengths



Collets
pg. 49



Nuts
pg. 64



Coolant
Rings
pg. 66



Retention
Knobs
pg. 228



Wrenches
pg. 232



Tightening
Stands
pg. 234



Coolant Options

- ER coolant rings (pg. 66)
- ER Steel Sealed collets (pg. 56)
- ER Sealed coolant collets (pg. 58)

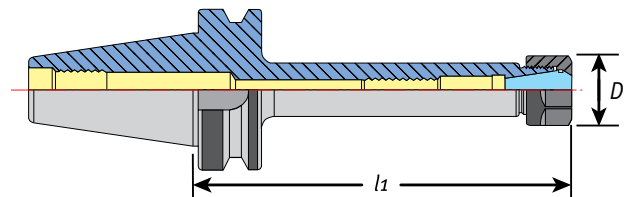

BT30 ER DualDRIVE Toolholders

Part No.	Description - l1	l1	D	Collet	Max. Shank	Set Screw	Wrench
25.122.16.060	BT30 x ER16 - 60mm DualDRIVE	60mm	27.43mm	ER16	.406"	16083	04609
25.122.16.090	BT30 x ER16 - 90mm DualDRIVE	90mm	27.43mm	ER16	.406"	16083	04609
25.122.16.105	BT30 x ER16 - 105mm DualDRIVE	105mm	27.43mm	ER16	.406"	16083	04609
25.122.20.105	BT30 x ER20 - 105mm DualDRIVE	105mm	34.04mm	ER20	.512"	16087	04610
25.122.20.060	BT30 x ER20 - 60mm DualDRIVE	60mm	34.04mm	ER20	.512"	16087	04610
25.122.20.090	BT30 x ER20 - 90mm DualDRIVE	90mm	34.04mm	ER20	.512"	16087	04610
25.122.25.060	BT30 x ER25 - 60mm DualDRIVE	60mm	41.91mm	ER25	.63"	16089	04615
25.122.32.060	BT30 x ER32 - 60mm DualDRIVE	60mm	50.04mm	ER32	.788"	16089	04616
25.122.32.090	BT30 x ER32 - 90mm DualDRIVE	90mm	50.04mm	ER32	.788"	16089	04616
25.122.40.080	BT30 x ER40 - 80mm DualDRIVE	80mm	62.99mm	ER40	1.023"	16091	04617

Coolant Set Screws page 47.

Dual-Contact Spindles

Use Techniks DualDRIVE holders if your machine has a dual-contact spindle. Dual-Contact is a spindle option offered by some machine tool builders.

Dual-contact means both the toolholder taper and the flange make contact with the spindle. Dual-contact increases rigidity and accuracy during machining.

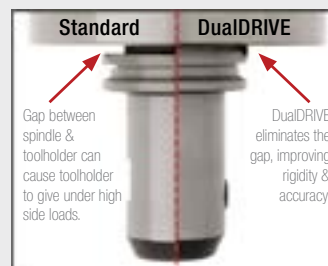

See our demonstration video of DualDRIVE at:
<http://ow.ly/sUOqL>



BT40 Precision ER Toolholders



Techniks Certified for accuracy and balance. Each holder comes with a complete lab report. A PowerCOAT nut is included with each holder.

Features

- *Balanced to 25,000 RPM at G2.5*
- *T.I.R. 0.0001" measured from taper to collet pocket*
- *PowerCOAT nut included for 75% more clamping power*

For ER16 and 20 slotted nuts, add SLOTNUT to the end of the part number. For holders with coolant nut included add -C to the end of the part number. Coolant nuts are not available for ER50.



Collets
pg. 49



Nuts
pg. 64



Coolant
Rings
pg. 66



Retention
Knobs
pg. 228



Wrenches
pg. 232



Tightening
Stands
pg. 234



Coolant Options

- *ER coolant rings (pg. 66)*
- *ER Steel Sealed collets (pg. 56)*
- *ER Sealed coolant collets (pg. 58)*

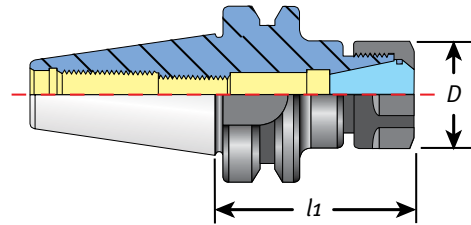

BT40 ER Toolholders

Part No.	Description	l1	D	Max. Shank	Set Screw	Wrench
16151	BT40 x ER16 - 70mm, hex nut	70mm	1.08"	.406"	16083	04609
16153	BT40 x ER16 - 100mm, hex nut	100mm	1.08"	.406"	16083	04609
16155	BT40 x ER16 - 125mm, hex nut	125mm	1.08"	.406"	16083	04609
16157	BT40 x ER16 - 150mm, hex nut	150mm	1.08"	.406"	16083	04609
16158	BT40 x ER16 - 180mm, hex nut	180mm	1.08"	.406"	16083	04609
16159	BT40 x ER20 - 70mm, hex nut	70mm	1.34"	.512"	16085	04610
16162	BT40 x ER20 - 100mm, hex nut	100mm	1.34"	.512"	16085	04610
16165	BT40 x ER20 - 135mm, hex nut	135mm	1.34"	.512"	16085	04610
16167	BT40 x ER20 - 150mm, hex nut	150mm	1.34"	.512"	16085	04610
16169	BT40 x ER25 - 70mm, slotted nut	70mm	1.65"	.630"	16089	04615
16171	BT40 x ER25 - 100mm, slotted nut	100mm	1.65"	.630"	16089	04615
16175	BT40 x ER25 - 150mm, slotted nut	150mm	1.65"	.630"	16089	04615
16177	BT40 x ER32 - 70mm, slotted nut	70mm	1.97"	.788"	16089	04616
16179	BT40 x ER32 - 100mm, slotted nut	100mm	1.97"	.788"	16089	04616
16181	BT40 x ER32 - 150mm, slotted nut	150mm	1.97"	.788"	16089	04616
161	BT40 x ER32 - 200mm, slotted nut	200mm	1.97"	.788"	16089	04616
16183	BT40 x ER40 - 80mm, slotted nut	80mm	2.48"	1.023"	16089	04617
16185	BT40 x ER40 - 100mm, slotted nut	100mm	2.48"	1.023"	16089	04617
16189	BT40 x ER40 - 150mm, slotted nut	150mm	2.48"	1.023"	16089	04617

BT40 Precision ER CoolFLEX Toolholders



Techniks Certified for accuracy and balance. Each holder comes with a complete lab report. A PowerCOAT nut is included with each holder.

Features

- Balanced to 25,000 RPM at G2.5
- Coolant-thru spindle or thru flange (DIN B)
- T.I.R. 0.0001" or better from taper to collet pocket

For ER16 and 20 slotted nuts, add SLOTNUT to the end of the part number. For holders with coolant nut included add -C to the end of the part number. Coolant nuts are not available for ER50.



Collets
pg. 49



Nuts
pg. 64



Coolant
Rings
pg. 66



Retention
Knobs
pg. 228



Wrenches
pg. 232



Tightening
Stands
pg. 234

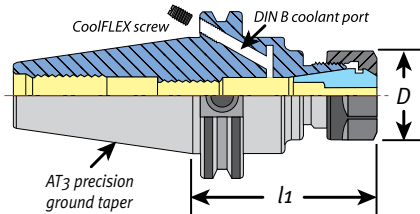

CoolFLEX Feature

CoolFLEX holders are factory set for coolant-thru spindle. Simply remove 2 stop screws for DIN B coolant-thru flange.

Part No.	Description
HSA-4-6	40 taper DIN B screw

thru flange

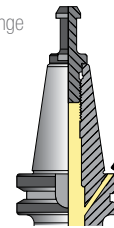

thru spindle

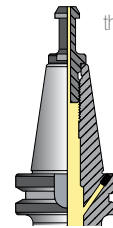

Coolant Set Screws page 47.

BT40 CoolFLEX Coolant -Thru Spindle or Flange (DIN B)

Part No.	Description	l1	D	Max. Shank	Set Screw	Wrench
16151F	BT40 x ER16 - 70mm, hex nut, CoolFLEX	70mm	1.08"	.406"	16083	04609
16153F	BT40 x ER16 - 100mm, hex nut, CoolFLEX	100mm	1.08"	.406"	16083	04609
16157F	BT40 x ER16 - 150mm, hex nut, CoolFLEX	150mm	1.08"	.406"	16083	04609
16159F	BT40 x ER20 - 70mm, hex nut, CoolFLEX	70mm	1.34"	.512"	16085	04610
16162F	BT40 x ER20 - 100mm, hex nut, CoolFLEX	100mm	1.34"	.512"	16085	04610
16167F	BT40 x ER20 - 150mm, hex nut, CoolFLEX	150mm	1.34"	.512"	16085	04610
16177F	BT40 x ER32 - 70mm, slotted, CoolFLEX	70mm	1.97"	.788"	16089	04616
16181F	BT40 x ER32 - 150mm, slotted, CoolFLEX	150mm	1.97"	.788"	16089	04616

Blue indicates coolant.



BT40 Precision ER Mini Nut Holders



Features

- Balanced to 25,000 RPM at G2.5
- T.I.R. 0.0001" measured from taper to collet pocket
- Taper ground to AT3 accuracy or better



PowerCOAT nut is included with each holder
Techniks Certified for accuracy and balance
Each holder comes with a complete lab report



Collets
pg. 49



Nuts
pg. 64



Coolant
Rings
pg. 66



Retention
Knobs
pg. 228



Wrenches
pg. 232



Tightening
Stands
pg. 234



Coolant Options

- ER coolant rings (pg. 66)
- ER Steel Sealed collets (pg. 56)
- ER Sealed coolant collets (pg. 58)

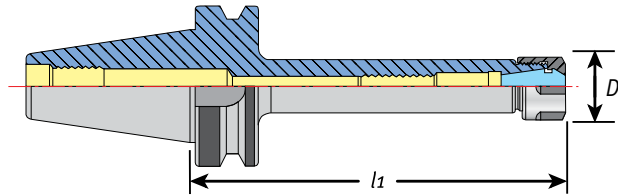

BT40 ER Mini Nut Holders

Part No.	Description	l1	D	Max. Shank	Set Screw	Wrench
16321	BT40 x ER11 - 70mm, mini nut	70mm	16mm	.275"	16081	04621
16324	BT40 x ER11 - 150mm, mini nut	150mm	16mm	.275"	16081	04621
16325	BT40 x ER16 - 70mm, mini nut	70mm	22mm	.406"	16083	04622
16328	BT40 x ER16 - 150mm, mini nut	150mm	22mm	.406"	16083	04622
16328-200	BT40 x ER16 - 200mm, mini nut	200mm	22mm	.406"	16083	04622
16329	BT40 x ER20 - 70mm, mini nut	70mm	28mm	.512"	16087	04623
16330	BT40 x ER20 - 100mm, mini nut	100mm	28mm	.512"	16087	04623
16332	BT40 x ER20 - 150mm, mini nut	150mm	28mm	.512"	16087	04623

Coolant Set Screws page 47.

BT40 Precision SuperRIGID Holders



Features

- *Balanced to 25,000 RPM at G2.5*
- *Best T.I.R. and Z axis of any collet chuck*
- *SuperRIGID for high torque or high speed machining*



Techniks Certified for accuracy and balance
 Each holder comes with a complete lab report
 Collet nut is included with each holder

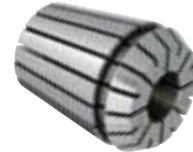

Use SuperRIGID holders with ER32 collets.

SuperRIGID Holders

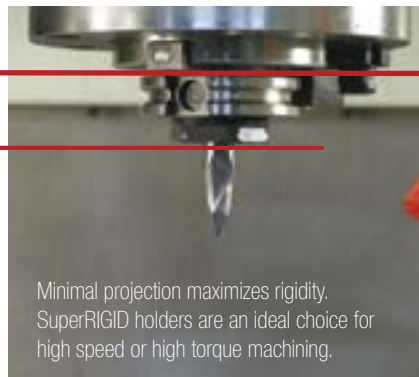

minimum projection

Minimal projection maximizes rigidity. SuperRIGID holders are an ideal choice for high speed or high torque machining.

Standard Holders

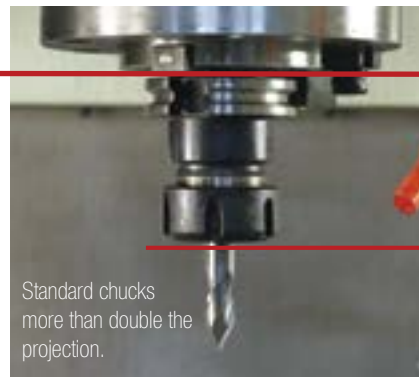

standard projection

Standard chucks more than double the projection.

Minimum projection = increased rigidity, better T.I.R. and extended cutter life.

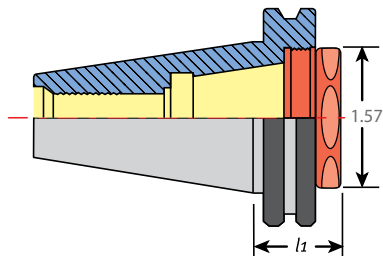

PowerCOAT
TE-22HN Nut

BT40 SuperRIGID ER Toolholders

Part No.	Description	l1	Collet	Max. Shank	Wrench
16177S	BT40 x ER32	36mm	ER32	3/4" or 20mm	894-36
TE-22HN	hex style PowerCOAT nut				



BT50 Precision ER Toolholders



Techniks Certified for accuracy and balance. Each holder comes with a complete lab report. A PowerCOAT nut is included with each holder.

Features

- *Balanced to 25,000 RPM at G2.5*
- *T.I.R. 0.0001" measured from taper to collet pocket*
- *PowerCOAT nut included for 75% more clamping power*

For ER16 and 20 slotted nuts, add SLOTNUT to the end of the part number. For holders with coolant nut included add -C to the end of the part number. Coolant nuts are not available for ER50.



Collets
pg. 49



Nuts
pg. 64



Coolant
Rings
pg. 66



Retention
Knobs
pg. 228



Wrenches
pg. 232



Tightening
Stands
pg. 234



Coolant Options

- *ER coolant rings (pg. 66)*
- *ER Steel Sealed collets (pg. 56)*
- *ER Sealed coolant collets (pg. 58)*

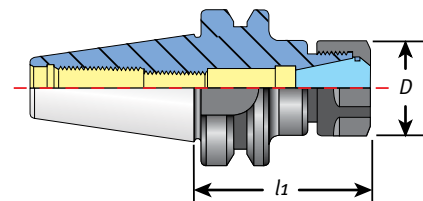

Coolant Set Screws page 47.

BT50 Precision Toolholders

Part No.	Description	l1	D	Max. Shank	Set Screw	Wrench
16251	BT50 x ER16 - 70mm, hex nut	70mm	1.08"	.406"	16083	04609
16252	BT50 x ER16 - 90mm, hex nut	90mm	1.08"	.406"	16083	04609
16253	BT50 x ER16 - 105mm, hex nut	105mm	1.08"	.406"	16083	04609
16254	BT50 x ER16 - 135mm, hex nut	135mm	1.08"	.406"	16083	04609
16255	BT50 x ER16 - 150mm, hex nut	150mm	1.08"	.406"	16083	04609
16263	BT50 x ER20 - 90mm, hex nut	90mm	1.34"	.512"	16087	04610
16265	BT50 x ER20 - 105mm, hex nut	105mm	1.34"	.512"	16087	04610
16267	BT50 x ER20 - 135mm, hex nut	135mm	1.34"	.512"	16087	04610
16271	BT50 x ER20 - 165mm, hex nut	165mm	1.34"	.512"	16087	04610
16275	BT50 x ER25 - 105mm, slotted nut	105mm	1.65"	.630"	16089	04615
16277	BT50 x ER25 - 135mm, slotted nut	135mm	1.65"	.630"	16089	04615
16279	BT50 x ER25 - 165mm, slotted nut	165mm	1.65"	.630"	16089	04615
16281	BT50 x ER32 - 80mm, slotted nut	80mm	1.97"	.788"	16089	04616
16283	BT50 x ER32 - 120mm, slotted nut	120mm	1.97"	.788"	16089	04616
16284	BT50 x ER32 - 150mm, slotted nut	150mm	1.97"	.788"	16089	04616
16285	BT50 x ER40 - 80mm, slotted nut	80mm	2.48"	1.023"	16091	04617
16289	BT50 x ER40 - 135mm, slotted nut	135mm	2.48"	1.023"	16091	04617
06291	BT50 x ER50 - 90mm, slotted nut	90mm	3.07"	1.338"	16093	04618

HSK32A, 40A, 50A, 63A Precision ER Toolholders



Techniks Certified for accuracy and balance. Each holder comes with a complete lab report. A PowerCOAT nut is included with each holder.

Features

- Balanced to 25,000 RPM at G2.5
- T.I.R. 0.0001" measured from taper to collet pocket
- PowerCOAT nut included for 75% more clamping power

For ER16 and 20 slotted nuts, add SLOTNUT to the end of the part number. For holders with coolant nut included add -C to the end of the part number. Coolant nuts are not available for ER50.

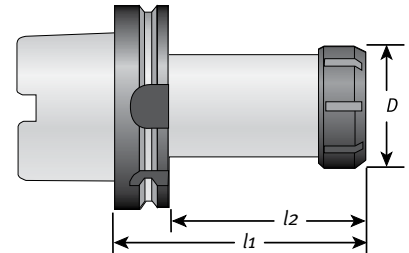

HSK32A, 40A, 50A, Toolholders

Part No.	Description	l1	l2	D	Wrench
31278	HSK32A x ER20 - 80mm, slotted nut	80mm	60mm	34mm	04614
31284	HSK32A x ER25 - 80mm, mini nut	80mm	60mm	35mm	04624
31374	HSK40A x ER11 - 80mm, mini nut	80mm	60mm	16mm	04621
31376	HSK40A x ER16 - 80mm, hex nut	80mm	54mm	28mm	04609
31384	HSK40A x ER25 - 80mm, slotted nut	80mm	60mm	35mm	04624
31385	HSK40A x ER32 - 80mm, slotted nut	80mm	60mm	50mm	04616
31420	HSK50A x ER32 - 100mm, slotted nut	100mm	74mm	50mm	04616

HSK63A Toolholders

Part No.	Description	l1	l2	D	Wrench
NEW 31430	HSK63A x ER11 - 100mm, mini nut	100mm	74mm	16mm	04621
31432	HSK63A x ER16 - 80mm, hex nut	80mm	54mm	28mm	04609
31434	HSK63A x ER16 - 100mm, hex nut	100mm	74mm	28mm	04609
31438	HSK63A x ER16 - 160mm, hex nut	160mm	134mm	28mm	04609
31440	HSK63A x ER20 - 80mm, hex nut	80mm	54mm	34mm	04610
31446	HSK63A x ER20 - 160mm, hex nut	160mm	134mm	34mm	04610
31462	HSK63A x ER32 - 100mm, slotted nut	100mm	74mm	50mm	04616
NEW 31466	HSK63A x ER32 - 160mm, slotted nut	160mm	134mm	50mm	04616
NEW 31466-8T	HSK63A x ER32 - 8", tapered style, slot nut	8"	134mm	50mm	04616
31468	HSK63A x ER40 - 80mm, slotted nut	80mm	54mm	63mm	04617
31472	HSK63A x ER40 - 120mm, slotted nut	120mm	94mm	63mm	04617
NEW 31476-8T	HSK63A x ER40 - 8", tapered style, slot nut	8"	94mm	63mm	04617

(Part Numbers with a -8T suffix indicate tapered style holder. Taper improves rigidity at extended lengths)



HSK100A Precision ER Toolholders



Features

- Balanced to 25,000 RPM at G2.5
- T.I.R. 0.0001" measured from taper to collet pocket
- PowerCOAT nut included for 75% more clamping power

For ER16 and 20 slotted nuts, add SLOTNUT to the end of the part number. For holders with coolant nut included add -C to the end of the part number. Coolant nuts are not available for ER50.



Techniks Certified for accuracy and balance. Each holder comes with a complete lab report. A PowerCOAT nut is included with each holder.

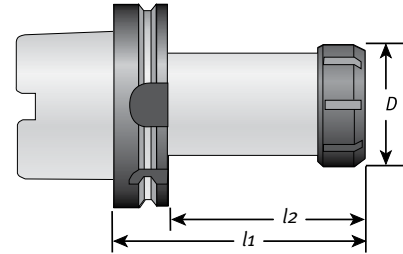

HSK100A Toolholders

Part No.	Description	l1	l2	D	Wrench
31484	HSK100A x ER16 - 100mm, hex nut	100mm	74mm	28mm	04609
31486	HSK100A x ER16 - 160mm, hex nut	160mm	134mm	28mm	04609
31490	HSK100A X ER20 - 100mm, hex nut	100mm	74mm	34mm	04610
31492	HSK100A X ER20 - 160mm, hex nut	160mm	134mm	34mm	04610
31494	HSK100A X ER25 -100mm, slotted nut	100mm	74mm	35mm	04624
31498	HSK100A x ER32 - 100mm, slotted nut	100mm	71mm	50mm	04616
31503	HSK100A x ER32 - 160mm, slotted nut	160mm	134mm	50mm	04616
31506	HSK100A x ER40 - 120mm, slotted nut	120mm	91mm	63mm	04617

HSKA Coolant Pipe and Wrench for HSKA and HSKE

Part No.	Description	HSK-AE	D	T	Wrench
92002	Coolant Pipe	40	8mm	M12 x 1	91.11.026.002
92003	Coolant Pipe	50	10mm	M16 x 1	92.11.026.003
92004	Coolant Pipe	63	12mm	M18 x 1	93.11.026.004
92005	Coolant Pipe	100	16mm	M24 x 1.5	95.11.026.005

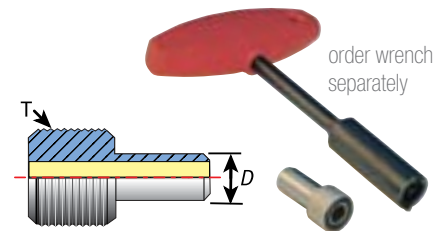

ISO & SK Holders for CNC Routers



Techniks Certified for accuracy and balance
Each holder comes with a complete lab report

Features

- *Balanced up to 40,000 RPM at G2.5*
- *T.I.R. 0.0001" or better from taper to collet pocket*
- *PowerCOAT nut and retention knob included*

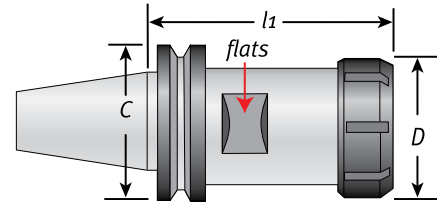

ISO 20 and ISO 25 Toolholders for CNC Routers

Part No.	Description	l1	C	D	Nut	Wrench	Flats
16000-2016MC	*ISO 20 x ER16 - 52mm, HS mini nut & pull stud	52mm	30mm	22mm	53116	04622	17
16000-2516	ISO 20 x ER16 - 52mm, slotted nut & pull stud	52mm	30mm	32mm	46116	04613	17
16000-2520	ISO 20 x ER20 - 52mm, slotted nut & pull stud	52mm	30mm	35mm	46120	04614	17
12194-ISO25	ISO 25 x ER25 - 50mm, slotted nut & pull stud	50mm	38mm	42mm	46125	04615	27
25077	ISO 25 x ER25 - 65mm, slotted nut & pull stud	65mm	38mm	42mm	23111	04615	27

*Balanced to 40,000 RPM. Use for Haas OM-1A, OM-2A Office Mills.

Haas is trademark of Haas Automation and used here for identification only.



Taper ground to AT3 accuracy or better
Techniks Certified for accuracy and balance

Features

- *Balanced to 25,000 RPM at G2.5*
- *T.I.R. 0.0001" or better from taper to collet pocket*
- *PowerCOAT nut included for 75% more clamping power*

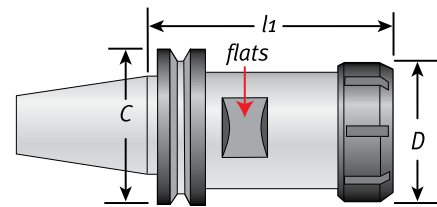

ISO 30 and SK 30 Toolholders for CNC Routers

Part No.	Description	l1	C	D	Nut	Wrench	Flats
42407-W	ISO 30 x ER11 - 100mm, mini nut	100mm	50mm	16mm	23111	04621	14
42213-W-50	ISO 30 x ER32 - 50mm, slotted nut	50mm	50mm	50mm	46132	04616	47
42213-W-63	ISO 30 x ER32 - 63mm, slotted nut	63mm	50mm	50mm	46132	04616	36
42213-W-90	ISO 30 x ER32 - 90mm, slotted nut	90mm	50mm	50mm	46132	04616	36
12000-CMS	ISO 30 x ER32 - CMS toolholder	58mm	46mm	50mm	46132	04616	36
12040-CMS	ISO 30 x ER40 - CMS toolholder	66mm	46mm	63mm	46140	04617	42
42215-W-57	ISO 30 x ER40 - 57mm, slotted nut	57mm	50mm	63mm	46140	04617	47
42261-W	ISO 40 x ER40 - 70mm, slotted nut	70mm	63.55mm	63mm	46140	04617	46
NT-54300130	SK-30 x SYOZ 25 toolholder	63mm	50mm	60mm	83632	03691	38



BT30 & BT35 Holders for CNC Routers



PowerCOAT nut is included with each holder
Techniks Certified for accuracy and balance
Each holder comes with a complete lab report

Features

- Balanced to 25,000 RPM at G2.5
- T.I.R. 0.0001" measured from taper to collet pocket
- PowerCOAT nut included for 75% more clamping power

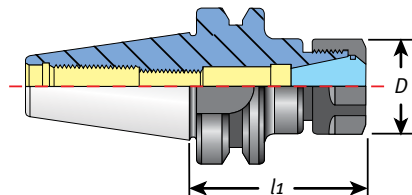

Coolant Set Screws page 47.

BT30, ER Toolholders

Part No.	Description	l1	D	Collet Nut	Set Screw	Wrench
16106-W	BT30 x ER20 - 70 without slots	70mm	34mm	41120	16087	04614
16121	BT30 x ER32 - 60, 41mm flats - Komo	60mm	50mm	46132	16089	04616
16131	BT30 x ER32 - 90 38mm flats - Komo	90mm	50mm	46132	16089	04616

BT30, SYOZ 25 Toolholders

Part No.	Description	l1	D	Collet Nut	Wrench
16001-W	BT30 x SYOZ 25 - 70, 38mm flats	70mm	60mm	83632	03691
16001	BT30 x SYOZ 25 - 70 with nut	70mm	60mm	83632	03691

BT 35, ER32, SYOZ 25 Toolholders for Heian Routers

Part No.	Description	l1	D	Collet Nut	Wrench
16010	BT 35 x SYOZ 25 - 76 with nut	76mm	60mm	83632	03691
161-BT35-ER32 76	BT 35 x ER32 - 76	76mm	50mm	46132	04616



Scan the QR code with a smartphone or enter this url: <http://ow.ly/rKs6W> to request our new CNC Router Tooling catalog. Or call us at 800.597.3921 to have it sent to you.



HSKE & HSKF Holders for CNC Routers



Techniks Certified for accuracy and balance

Features

- Balanced to 25,000 RPM at G2.5
- T.I.R. 0.0001" measured from taper to collet pocket
- PowerCOAT nut included for 75% more clamping power

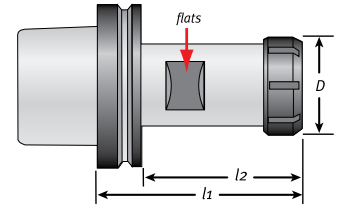

Coolant Set Screws page 47.

HSK32E, 40E, 50E, 63E Toolholders for HSK E Type Spindle

Part No.	Description	l1	l2	D	Nut	Set Screw	Wrench	Flats
31374-60-E	HSK32E x ER25 - 60mm, slotted nut	60mm	27mm	42mm	46125	16089	04615	22mm
31376-E	HSK40E x ER16 - 65mm, slotted nut	65mm	45mm	32mm	46116	16083	04613	24mm
31383-E	HSK40E x ER25 - 75mm, slotted nut	75mm	55mm	42mm	46125	16089	04615	27mm
31386-E	HSK40E x ER32 - 100mm, slotted nut	100mm	80mm	50mm	46132	16089	04616	35mm
31402-E	HSK50E x ER16 - 80mm, slotted nut	80mm	60mm	28mm	46116	16083	04613	27mm
31419-E	HSK50E x ER32 - 85mm, slotted nut	85mm	59mm	50mm	46132	16089	04616	36mm
31456-E	HSK63E x ER32 - 90mm, slotted nut	90mm	64mm	50mm	46132	16089	04616	36mm
31472-E	HSK63E x ER40 - 120mm, slotted nut	120mm	94mm	63mm	46140	16091	04617	46mm
50001	HSK63E x ER40 -75mm, slotted nut	75mm	49mm	63mm	46140	16091	04617	46mm



Techniks Certified for accuracy and balance

Features

- Balanced to 25,000 RPM at G2.5
- T.I.R. 0.0001" measured from taper to collet pocket
- PowerCOAT nut included for 75% more clamping power

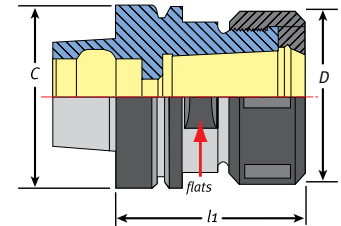

HSK50F, 63F Toolholders for CNC Routers

Part No.	Description	l1	D	Nut	Wrench	Flats
31419-F	HSK50F x ER32 - 80mm, slotted nut	80mm	50mm	46132	04616	36mm
103.123.11.100	HSK63F x ER11 - 100mm	100mm	16mm	23111	04621	-
31431-F	HSK63F x ER16 - 60mm, slotted nut	60mm	32mm	46116	04613	26mm
31434-F	HSK63F x ER16 - 100mm, slotted nut	100mm	32mm	46116	04613	26mm
30000	HSK63F x ER32 - 70mm, slotted nut	70mm	50mm	46132	04616	36mm
30001	HSK63F x ER40 - 75mm, slotted nut	75mm	63mm	46140	04617	46mm
30001-L	HSK63F x ER40 - 75mm, left-hand thread	75mm	63mm	46140-L	04617	46mm
30001-Solid	HSK63F x ER40 - 75mm, No thru hole	75mm	63mm	46140	04617	46mm
30002	HSK63F x ER40 - 90mm, slotted nut	90mm	63mm	46140	04617	46mm
30003	HSK63F x ER40 - 115mm, slotted nut	115mm	63mm	46140	04617	46mm
30005	HSK63F x ER40 - 125mm, slotted nut	125mm	63mm	46140	04617	46mm
31025F	HSK63 F x SYOZ 25 - 80mm, slotted nut	80mm	60mm	83632	03691	38mm



We stand behind all our products with our 100% Satisfaction Guarantee • www.techniksusa.com

Precision ER Mini-Nut & Straight Shank Extensions



Features

- Collet pocket T.I.R. 0.0001"
- PowerCOAT Nut included

For shank sizes 1/8" (3mm) or smaller use our DNA (dead nuts accurate) collets for best results (pg 48).

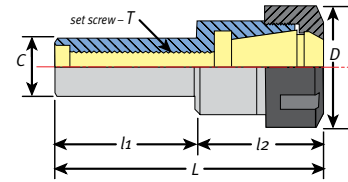

Coolant Set Screws page 47.

ER Straight Shank Extensions

Part No.	Description	C	L	I1	I2	D	Set Screw	Wrench
04851	16mm x ER11, - 140mm, hex nut	16mm	174.5mm	140mm	21.6mm	19mm	-	04608
04855	1/2" x ER11, - 140mm, hex nut	1/2"	174.5mm	140mm	21.6mm	19mm	-	04608
04854	5/8" x ER11, - 140mm, hex nut	5/8"	174.5mm	140mm	21.6mm	19mm	-	04608
04832	5/8" x ER16, - 60mm, hex nut	5/8"	95.1mm	60mm	35.1mm	28mm	-	04609
04834	3/4" x ER16, - 50mm, hex nut	3/4"	85.1mm	50mm	35.1mm	28mm	16083	04609
04835	3/4" x ER16, - 100mm, hex nut	3/4"	135.1mm	100mm	35.1mm	28mm	16083	04609
04856	3/4" x ER16, - 140mm, hex nut	3/4"	175.1mm	140mm	35.1mm	28mm	16083	04609
04836-2.5	3/4" x ER20, - 2-1/2", hex nut	3/4"	100mm	2-1/2"	38mm	34mm	16083	04610
04858	1.0" x ER20, - 140mm, hex nut	1.0"	180.5mm	140mm	40.5mm	34mm	16083	04610
04837	1.0" x ER25, - 50mm, slotted nut	1.0"	101mm	50mm	51mm	42mm	16089	04615
04817	20mm x ER32, - 50mm, slotted nut	20mm	97.1mm	50mm	47mm	50mm	16089	04616
04818	20mm x ER32, - 100mm, slotted nut	20mm	146.5mm	100mm	47mm	50mm	16083	04616
04818-150	20mm x ER32, - 150mm, slotted nut	20mm	196.5mm	150mm	47mm	50mm	16083	04616
04839	1.0" x ER32, - 50mm, slotted nut	1.0"	101.5mm	50mm	51.5mm	50mm	16089	04616
04839-140	1.0" x ER32, - 140mm, slotted nut	1.0"	191.5mm	140mm	51.5mm	50mm	16083	04616
04843	1-1/4" x ER32, - 60mm, slotted nut	1-1/4"	111.5mm	60mm	51.5mm	50mm	16089	04616
04841	1.0" x ER40, - 50mm, slotted nut	1.0"	115mm	50mm	65mm	63mm	16083	04617

Properly torque down the nut for best tool life. See the Torque Chart on page 41.



Features

- Collet pocket T.I.R. 0.0001"
- All surfaces precision ground
- PowerCOAT Nut included

Extension length should not exceed a 4 : 1 ratio of length to diameter.

Example: A 1/2" shank should not extend more than 2" in front of the holder.

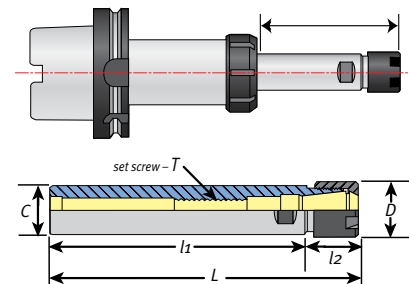

Mini-Nut ER Straight Shank Extensions

Part No.	Description	C	L	I1	I2	D	Set Screw	Wrench
04889	3/8" x ER8, - 100mm	3/8"	124mm	100mm	24mm	12mm	-	04620
04891	1/2" x ER11, - 140mm	1/2"	166.5mm	140mm	26.5mm	16mm	-	04621
04893	5/8" x ER11, - 140mm	5/8"	158.5mm	140mm	18.5mm	16mm	-	04621
04895	1/2" x ER16, - 140mm	1/2"	177mm	140mm	37mm	22mm	-	04622
04896	3/4" x ER16, - 140mm	3/4"	165mm	140mm	25mm	22mm	16083	04622
04892	1/2" x ER20, - 140mm	1/2"	180mm	140mm	40mm	28mm	16083	04623
04894	3/4" x ER20, - 140mm	3/4"	180mm	140mm	40mm	28mm	16083	04623
04881	20mm x ER20, - 180mm	20mm	220mm	180mm	40mm	28mm	16083	04623
04897	1.0" x ER20, - 140mm	1.0"	168mm	140mm	28mm	28mm	16083	04623
04898	3/4" x ER25, - 100mm	3/4"	149mm	100mm	49mm	35mm	16087	04624
04888	1.0" x ER25, - 140mm	1.0"	190mm	140mm	50mm	35mm	16083	04624

Precision ER Coolant-Thru Shanks & ER Double Ended



No. 04805-C

Features

- For coolant up to 1,500 PSI
- Collet pocket T.I.R. 0.0001"
- PowerCOAT coolant nut included

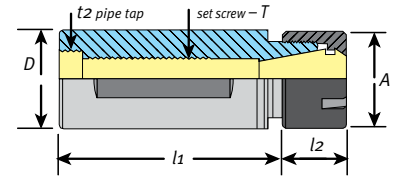

Use with Black Gold ER coolant rings for coolant-thru 04808C available with 1/8" NPT side entry coolant. Mini Coolant nuts page 59. Coolant-thru-tool set screws page 41.

Coolant-Thru Straight Shank Extensions

Part No.	Description	l1	l2	D	T	t2	A	Wrench
04802-C	3/4" x ER16, - 2" shank, coolant mini nut	1.65"	.916"	3/4"	m10 x 1.5	1/4" NPT	22mm	04622
04803-C	3/4" x ER16, - 3" shank, coolant mini nut	2.44"	.916"	3/4"	m10 x 1.5	1/4" NPT	22mm	04622
04804-C	3/4" x ER16, - 4" shank, coolant mini nut	3.42"	.916"	3/4"	m10 x 1.5	1/4" NPT	22mm	04622
04805-C	1.0" x ER20, - 3" shank, coolant mini nut	2.01"	1.07"	1.0"	m12 x 1.75	3/8" NPT	1.10"	04623
04806-C	1.0" x ER20, - 4" shank, coolant mini nut	3.31"	1.07"	1.0"	m12 x 1.75	3/8" NPT	1.10"	04623
04808-C	1.25" x ER32, - 2.36" shank, slotted nut	2.36"	2.16"	1-1/4"	m12 x 1.75	3/8" NPT	1.97"	04616

Blue indicates coolant.



O-ring seals coolant

Features

- For coolant up to 1,500 PSI
- Collet pocket T.I.R. 0.0001"
- PowerCOAT nut included

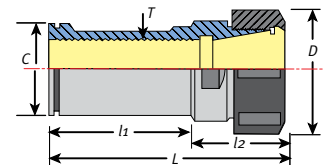

Perfect for CNC lathes and tapping applications. Seals coolant from the turret to the shank with an O-ring. Use black gold coolant rings (page 60) and PowerCOAT coolant nuts for coolant-thru tools, or CoolBLAST coolant for standard tools.

CNC Lathe Coolant-Thru Straight Shanks

Part No.	Description	C	l1	L	l2	D	T	Wrench
04782	1-1/4" x ER25, - 60mm shank	1-1/4"	60mm	97mm	37mm	42mm	M18 x 1.5	04615
04784	1-1/4" x ER32, - 60mm shank	1-1/4"	60mm	103mm	43mm	50mm	M22 x 1.5	04616
04788	1-1/2" x ER32, - 80mm shank	1-1/2"	80mm	118mm	38mm	50mm	M22 x 1.5	04616
04786	1-1/4" x ER40, - 60mm shank	1-1/4"	60mm	120mm	60mm	63mm	M28 x 1.5	04617
04790	1-1/2" x ER40, - 75mm shank	1-1/2"	75mm	135mm	60mm	63mm	M28 x 1.5	04617

Blue indicates coolant.

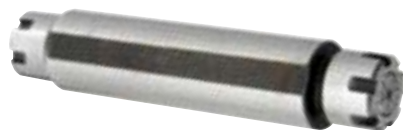

Features

- Collet pocket T.I.R. 0.0001"
- Wrench flats extend full length of shank

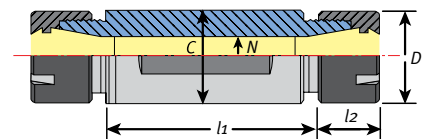

Double-Ended Straight Shank for CNC Swiss Machines

Part No.	Description	C	D	L1	L2	N	Wrench
04801-DE	3/4" x ER11, - 2.5" shank, double ended mini nut	3/4"	16mm	44mm	12mm	8mm	04621
04802-DE	3/4" x ER11, - 3.35" shank, double ended mini nut	3/4"	16mm	65mm	12mm	8mm	04621
04803-DE	3/4" x ER11, - 4.0" shank, double ended mini nut	3/4"	16mm	77mm	12mm	8mm	04621
04804-DE	3/4" x ER11, - 5.0" shank, double ended mini nut	3/4"	16mm	99.5mm	12mm	8mm	04621



TG75 & TG100 Precision Toolholders



Techniks Certified for accuracy and balance
Each holder comes with a complete lab report

Features

- *Balanced to 25,000 RPM at G2.5*
- *T.I.R. 0.0001" measured from taper to collet pocket*
- *PowerCOAT nut included for 75% more clamping power*

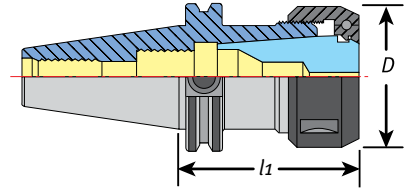

Coolant Set Screws page 47.

TG75 and TG100 Precision Toolholders

Part No.	Description	l1	D	Collet Range	Set Screw	Wrench
23008	CAT40 x TG75 - 2.75"	2.75"	1.88"	.094 - .750"	16089	04616
23014	CAT40 x TG100 - 3"	3"	2.362"	.094 - 1.0"	16093	03691
23016	CAT40 x TG100 - 4"	4"	2.362"	.094 - 1.0"	16093	03691
23018	CAT40 x TG100 - 6"	6"	2.362"	.094 - 1.0"	16093	03691
23030	CAT50 x TG100 - 3"	3"	2.362"	.094 - 1.0"	16093	03691
23032	CAT50 x TG100 - 4"	4"	2.362"	.094 - 1.0"	16093	03691
23034	CAT50 x TG100 - 6"	6"	2.362"	.094 - 1.0"	16093	03691
23035	CAT50 x TG100 - 8"	8"	2.362"	.094 - 1.0"	16093	03691



Techniks Certified for accuracy and balance
Each holder comes with a complete lab report

Features

- *Balanced to 25,000 RPM at G2.5*
- *Coolant-thru spindle or thru flange (DIN B)*
- *T.I.R. 0.0001" or better from taper to collet pocket*

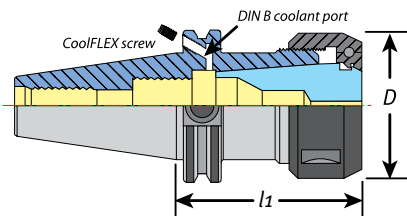

CoolFLEX Feature

CoolFLEX holders are factory set for coolant-thru spindle. Simply remove 2 stop screws for DIN B coolant-thru flange.

Part No. Description

HSA-4-6 40 taper DIN B screw

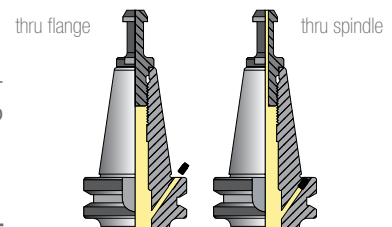

Coolant Set Screws page 47.

TG100 CoolFLEX Coolant-Thru Spindle or Flange (DIN B)

Part No.	Description	l1	D	Collet	Collet Range	Set Screw	Wrench
23014F	CAT40 CoolFLEX x TG100 - 3"	3"	2.362"	TG100	.094 - 1.0"	16093	03691
23016F	CAT40 CoolFLEX x TG100 - 4"	4"	2.362"	TG100	.094 - 1.0"	16093	03691
23018F	CAT40 CoolFLEX x TG100 - 6"	6"	2.362"	TG100	.094 - 1.0"	16093	03691
23030F	CAT50 CoolFLEX x TG100 - 3"	3"	2.362"	TG100	.094 - 1.0"	16093	03691

Blue indicates coolant.

Recommended Torque Values & Coolant Set Screws

Recommended Collet Nut & Retention Knob Tightening Torque

Collet	Nut Type	Collets I.D. OVER 1/16" (2mm)	Collets I.D. UNDER 1/16" (2mm)	Order Torque Wrench Adapter
ER16	slotted	42 ft/lbs	30 ft/lbs	04580-16
ER16	hex	42 ft/lbs	30 ft/lbs	04601-16
ER20	slotted	59 ft/lbs	24 ft/lbs	04580-20
ER20	hex	59 ft/lbs	24 ft/lbs	04602-20
ER25	slotted	77 ft/lbs	77 ft/lbs	04603-25
ER25	mini nut	25 ft/lbs	25 ft/lbs	04587
ER32	slotted	100 ft/lbs	100 ft/lbs	04604-32
ER40	slotted	130 ft/lbs	130 ft/lbs	04605-40
SYOZ 25	hook	90 ft/lbs	90 ft/lbs	03690-25
TG75	slotted	90 ft/lbs	90 ft/lbs	04604-32
TG100	hook	90 ft/lbs	90 ft/lbs	03690-25



Collets
pg. 49



Nuts
pg. 64



Coolant
Rings
pg. 66



Retention
Knobs
pg. 228



Wrenches
pg. 232



Tightening
Stands
pg. 234

Always tighten retention knobs to exact specification or damage to tooling or bodily harm may occur.

Retention Knobs	Wrench Flats	Drive	Torque	Order Socket
BT30 Taper	0.535"	1/4"	36 ft/lbs	PSS-30BT
ISO 30 Taper	0.535"	3/8"	36 ft/lbs	PSS-30ISO
Any 40 Taper	0.750"	3/8"	76 ft/lbs	PSS-40
BT50 Taper	1.187"	1/2"	99 ft/lbs	PSC-50
CAT50 Taper	1.250"	1/2"	99 ft/lbs	PSC-50

**Always use a torque wrench and tightening stand when tightening collet nuts and retention knobs. Overtightening collet nuts will cause premature damage to collets and increase run-out.



Use coolant set screws for coolant-thru tools or with Black Gold Rings for CoolBLAST option using standard cutting tools. See page 66 for more information.

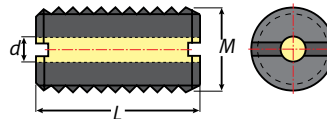

Coolant Set Screws

Part No.	Description	M	L	d
16080C-20	Coolant Set Screw	M5 x 0.8P	20mm	2.5
16082C-20	Coolant Set Screw	M8 x 1.25P	20mm	4
16083C-20	Coolant Set Screw	M10 x 1.5P	20mm	4
16085C-20	Coolant Set Screw	M12 x 1.75P	20mm	4
16089C-20	Coolant Set Screw	M16 x 02.0P	20mm	5
16091C-20	Coolant Set Screw	M20 x 2.0P	20mm	5

Blue indicates coolant.

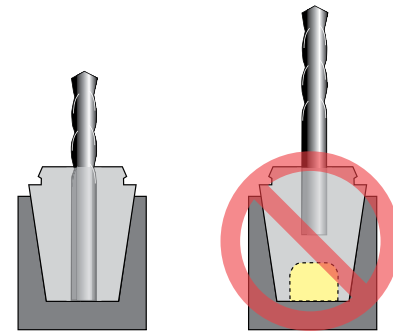

For maximum holding power fill the collet all the way with the tool shank (left) and use a PowerCOAT nut.

DIRECTIONS

- Snap collet into nut.
- Insert cutting tool into collet. Make sure shank extends to the bottom of the collet.
- Hand tighten collet nut assembly into toolholder.
- Insert toolholder assembly into tightening fixture and secure it.
- Tighten collet nut to recommended torque using a torque wrench and adapter.

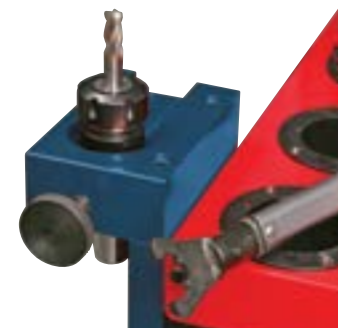

Measurement Guide for Special Order Toolholders

V-flange CNC machine
make, model and spindle

Fill in all the required dimensions (left).
Then, fax or phone in your order for a fast quote.

v-flange tool #1 dimensions

- D = _____
- F = _____
- W = _____
- A = _____
- N = _____

v-flange tool #2 dimensions

- D = _____
- F = _____
- W = _____
- A = _____
- N = _____

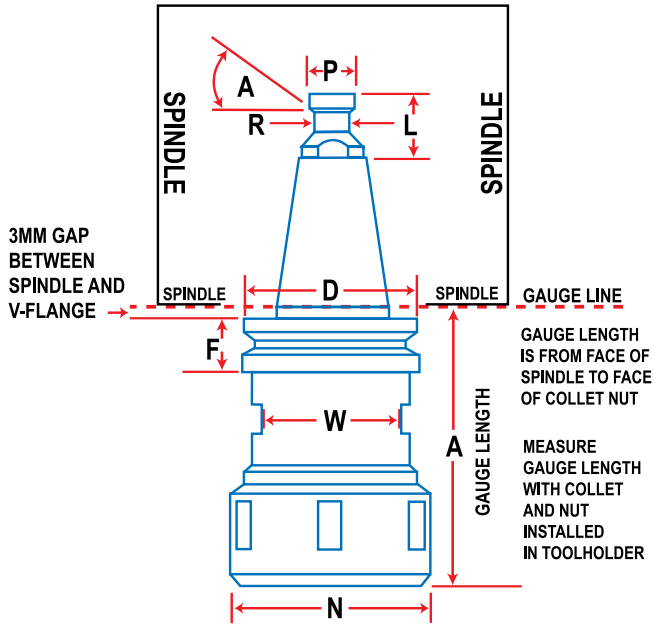

HSK CNC machine
make, model and spindle

HSK tool #1 dimensions

- D = _____
- F = _____
- W = _____
- A = _____
- N = _____

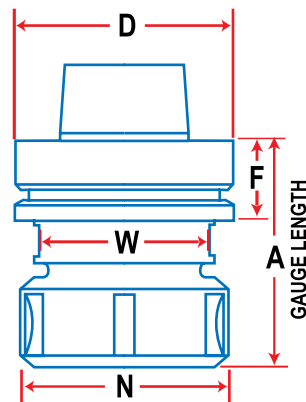

HSK tool #2 dimensions

- D = _____
- F = _____
- W = _____
- A = _____
- N = _____

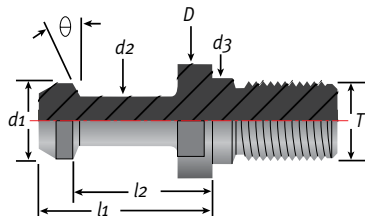

For special order retention knobs see page 231
or call (800) 597-3921

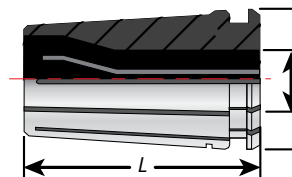

For special order collets see page 74 or
call (800) 597-3921

Precision ER Collets, PowerCOAT Nuts, Other Collets

Full Line of ER Collets

Made from high-carbon bearing steel and heat treated for improved flexibility and longer life.



Other Collet Styles



<http://ow.ly/risq>
View the video.

PowerCOAT Nut

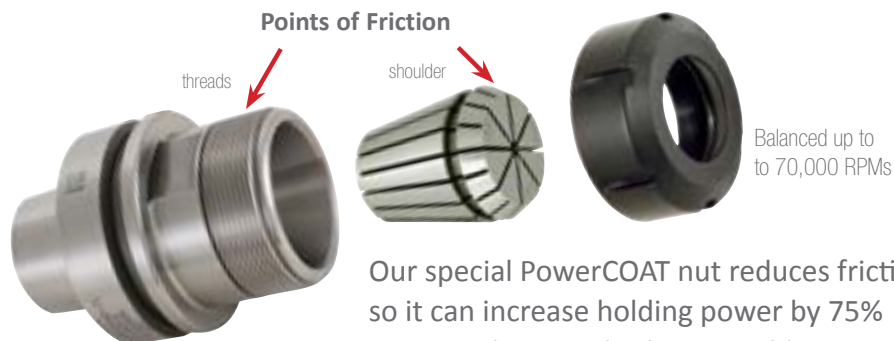

Our special PowerCOAT nut reduces friction so it can increase holding power by 75% compared to standard nuts. Holding power increases cutting tool life.

You lose 10% of tool life for every .0001" of T.I.R.
The holding power and accuracy of Techniks collets and PowerCOAT nuts extend cutting tool life.

Built for Speed.



All Techniks products are backed by our 100% satisfaction guarantee!



We stand behind all our products with our 100% Satisfaction Guarantee • www.techniksusa.com

Inch Size Precision ER Collets & Collet Sets

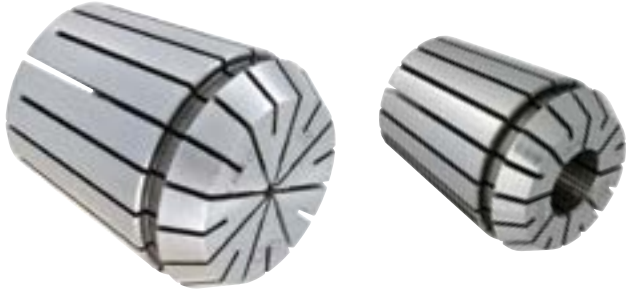

Inch Size ER Collet Features

- Average .0002" T.I.R.
- Collapse range: .039"
- Use with PowerCOAT nut for best holding power and cutting tool life.

Compatible with DR, RD, ESX, AR, & BR series collets.

Ultra Precision Collets

- .0002" T.I.R. or better
- To order put "UP" in front of the part number



Nuts
pg. 64



Coolant
Rings
pg. 66



Retention
Knobs
pg. 228



Wrenches
pg. 232

ER8 Inch Size Collets

Part No.	Collapse Range	Shank
04208-1/16	.043 – .062"	1/16"
04208-1/8	.086 – .125"	1/8"
04208-3/16	.148 – .187"	3/16"

ER Inch Size Collet Sets

Part No.	Size	Pieces	Collets Included	Fits Shank Sizes
04208IS	ER11	7	1/16 – 1/4" by 32nds	1/32 - 1/4"
04209IS	ER16	10	3/32 – 3/8" by 32nds	1/16 - 3/8"
04210IS	ER20	12	5/32 – 1/2" by 32nds	1/8 - 1/2"
04211IS	ER25	16	5/32 – 5/8" by 32nds	1/8 - 5/8"
04212IS	ER32	18	7/32 – 3/4" by 32nds	3/16 - 3/4"
04213IS	ER40	13	1/8 – 1.0" by 16ths	1/8 - 1.0"

NOTE: ER40 collet set does not include 13/16 and 15/16 size collets.

ER11 Inch Size Collets

Part No.	Collapse Range	Shank
04211-1/16	.043 – .062"	1/16"
04211-3/32	.054 – .093"	3/32"
04211-1/8	.086 – .125"	1/8"
04211-5/32	.117 – .156"	5/32"
04211-3/16	.148 – .187"	3/16"
04211-7/32	.179 – .218"	7/32"
04211-1/4	.211 – .250"	1/4"
04211-9/32	.242 – .281"	9/32"

ER16 Inch Size Collets

Part No.	Collapse Range	Shank
04216-1/16	.043 – .062"	1/16"
04216-3/32	.054 – .093"	3/32"
04216-1/8	.086 – .125"	1/8"
04216-5/32	.117 – .156"	5/32"
04216-3/16	.148 – .187"	3/16"
04216-7/32	.179 – .218"	7/32"
04216-1/4	.211 – .250"	1/4"
04216-9/32	.242 – .281"	9/32"
04216-5/16	.273 – .312"	5/16"
04216-11/32	.304 – .343"	11/32"
04216-3/8	.336 – .375"	3/8"
04216-13/32	.367 – .406"	13/32"

ER20 Inch Size Collets

Part No.	Collapse Range	Shank
04220-1/16	.043 – .062"	1/16"
04220-3/32	.054 – .093"	3/32"
04220-1/8	.086 – .125"	1/8"
04220-5/32	.117 – .156"	5/32"
04220-3/16	.148 – .187"	3/16"
04220-7/32	.179 – .218"	7/32"
04220-1/4	.211 – .250"	1/4"
04220-9/32	.242 – .281"	9/32"
04220-5/16	.273 – .312"	5/16"
04220-11/32	.304 – .343"	11/32"
04220-3/8	.336 – .375"	3/8"
04220-13/32	.367 – .406"	13/32"
04220-7/16	.398 – .437"	7/16"
04220-15/32	.429 – .468"	15/32"
04220-1/2	.461 – .500"	1/2"

Inch Size Precision ER Collets

ER25 Inch Size Collets

Part No.	Inch Range	Shank
04225-3/32	.054 – .093"	3/32"
04225-1/8	.086 – .125"	1/8"
04225-5/32	.117 – .156"	5/32"
04225-3/16	.148 – .187"	3/16"
04225-7/32	.179 – .218"	7/32"
04225-1/4	.211 – .250"	1/4"
04225-9/32	.242 – .281"	9/32"
04225-5/16	.273 – .312"	5/16"
04225-11/32	.304 – .343"	11/32"
04225-3/8	.336 – .375"	3/8"
04225-13/32	.367 – .406"	13/32"
04225-7/16	.398 – .437"	7/16"
04225-15/32	.429 – .468"	15/32"
04225-1/2	.461 – .500"	1/2"
04225-17/32	.492 – .531"	17/32"
04225-9/16	.523 – .562"	9/16"
04225-19/32	.554 – .593"	19/32"
04225-5/8	.586 – .625"	5/8"
04225-3/4	.711 – .750"	3/4"

ER32 Inch Size Collets

Part No.	Inch Range	Shank
04232-1/16	.043 – .062"	1/16"
04232-3/32	.054 – .093"	3/32"
04232-1/8	.086 – .125"	1/8"
04232-5/32	.117 – .156"	5/32"
04232-3/16	.148 – .187"	3/16"
04232-7/32	.179 – .218"	7/32"
04232-1/4	.211 – .250"	1/4"
04232-9/32	.242 – .281"	9/32"
04232-5/16	.273 – .312"	5/16"
04232-11/32	.304 – .343"	11/32"
04232-3/8	.336 – .375"	3/8"
04232-13/32	.367 – .406"	13/32"
04232-7/16	.398 – .437"	7/16"
04232-15/32	.429 – .468"	15/32"
04232-1/2	.461 – .500"	1/2"
04232-17/32	.492 – .531"	17/32"
04232-9/16	.523 – .562"	9/16"
04232-19/32	.554 – .593"	19/32"
04232-5/8	.586 – .625"	5/8"
04232-21/32	.617 – .656"	21/32"
04232-11/16	.648 – .687"	11/16"
04232-23/32	.679 – .718"	23/32"
04232-3/4	.711 – .750"	3/4"

ER40 Inch Size Collets

Part No.	Inch Range	Shank
04240-1/8	.086 – .125"	1/8"
04240-5/32	.117 – .156"	5/32"
04240-3/16	.148 – .187"	3/16"
04240-7/32	.179 – .218"	7/32"
04240-1/4	.211 – .250"	1/4"
04240-9/32	.242 – .281"	9/32"
04240-5/16	.273 – .312"	5/16"
04240-11/32	.304 – .343"	11/32"
04240-3/8	.336 – .375"	3/8"
04240-13/32	.367 – .406"	13/32"
04240-7/16	.398 – .437"	7/16"
04240-15/32	.429 – .468"	15/32"
04240-1/2	.461 – .500"	1/2"
04240-17/32	.492 – .531"	17/32"
04240-9/16	.523 – .562"	9/16"
04240-19/32	.554 – .593"	19/32"
04240-5/8	.586 – .625"	5/8"
04240-21/32	.617 – .656"	21/32"
04240-11/16	.648 – .687"	11/16"
04240-23/32	.679 – .718"	23/32"
04240-3/4	.711 – .750"	3/4"
04240-25/32	.742 – .781"	25/32"
04240-13/16	.773 – .812"	13/16"
04240-27/32	.807 – .843"	27/32"
04240-7/8	.836 – .875"	7/8"
04240-29/32	.867 – .906"	29/32"
04240-15/16	.898 – .937"	15/16"
04240-31/32	.929 – .968"	31/32"
04240-1	.961 – 1.00"	1.0"

Use the table (below) for selecting your replacement collets.
ER collets all have unique length and diameter measurements.

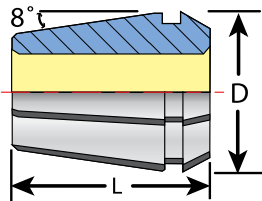

ER Size	L	D
ER8	13mm (.51")	8.5mm (.33")
ER11	18mm (.708")	11.5mm (.45")
ER16	27.5mm (1.08")	17mm (.67")
ER20	31.5mm (1.24")	21mm (.83")
ER25	34mm (1.34")	26mm (1.02")
ER32	40mm (1.57")	33mm (1.3")
ER40	46mm (1.81")	41mm (1.61")
ER50	60 mm (2.36")	52mm (2.05")

ER50 Inch Size Collets

Part No.	Inch Range	Shank
04250-1/2	.461 – .500"	1/2"
04250-5/8	.586 – .625"	5/8"
04250-3/4	.711 – .750"	3/4"
04250-7/8	.836 – .875"	7/8"
04250-1	.961 – 1.00"	1.0"
04250-1-1/4	1.211 – 1.250"	1-1/4"

Metric Size Precision ER Collets and Collet Sets



Compatible with DR, RD, ESX, AR, & BR series collets.

To Order Ultra Precision Collets

Hand-selected Ultra Precision collets are guaranteed .0002" T.I.R. or better. Just place "UP" in front of the regular part number when ordering.

Metric ER Precision Collet Features

- Average .0002" T.I.R.
- Clamping range: .039"
- Use with PowerCOAT nut (pg. 58) for best holding power and cutting tool life.



ER Metric Collet Sets

Part No.	Size	Pieces	Collets Included	Fits Shank Sizes
04200MS	ER8	9	1 - 5mm by 0.5mm	.5 – 5mm
04201MS	ER11	13	1 - 7mm by 0.5mm	.5 – 7mm
04202MS	ER16	10	1 - 10mm by 1mm	.5 – 10mm
04203MS	ER20	12	2 - 13mm by 1mm	1.0 – 13mm
04204MS	ER25	15	2 - 16mm by 1mm	1.0 – 16mm
04205MS	ER32	18	3 - 20mm by 1mm	2 – 20mm
04206MS	ER40	23	4 - 26mm by 1mm	3 – 26mm
04207MS	ER50	17	6 - 34mm by 2 mm	5 – 34mm

ER8 Precision Metric Collets

Part No.	Inch Range	Shank
04208-01.0	.019 – .039"	0.5 – 1.0
04208-01.5	.039 – .059"	1.0 – 1.5
04208-02.0	.059 – .079"	1.5 – 2.0
04208-02.5	.079 – .098"	2.0 – 2.5
04208-03.0	.098 – .118"	2.5 – 3.0
04208-03.5	.118 – .138"	3.0 – 3.5
04208-04.0	.138 – .157"	3.5 – 4.0
04208-04.5	.157 – .177"	4.0 – 4.5
04208-05.0	.177 – .197"	4.5 – 5.0

ER11 Precision Metric Collets

Part No.	Inch Range	Shank
04211-01.0	.019 – .039"	0.5 – 1.0
04211-01.5	.039 – .059"	1.0 – 1.5
04211-02.0	.059 – .079"	1.5 – 2.0
04211-02.5	.079 – .098"	2.0 – 2.5
04211-03.0	.098 – .118"	2.5 – 3.0
04211-03.5	.118 – .138"	3.0 – 3.5
04211-04.0	.138 – .157"	3.5 – 4.0
04211-04.5	.157 – .177"	4.0 – 4.5
04211-05.0	.177 – .197"	4.5 – 5.0
04211-05.5	.197 – .217"	5.0 – 5.5
04211-06.0	.217 – .236"	5.5 – 6.0
04211-06.5	.236 – .256"	6.0 – 6.5
04211-07.0	.256 – .276"	6.5 – 7.0

ER16 Precision Metric Collets

Part No.	Inch Range	Shank
04216-01	.019 – .039"	0.5–1
04216-01.5	.039 – .059"	1.0–1.5
04216-02	.039 – .079"	1.5–2
04216-02.5	.059 – .098"	1.5–2.5
04216-03	.079 – .118"	2–3
04216-03.5	.098 – .137"	2.5–3.5
04216-04	.118 – .157"	3–4
04216-04.5	.137 – .177"	3.5–4.5
04216-05	.157 – .197"	4–5
04216-05.5	.177 – .216"	4.5–5.5
04216-06	.197 – .236"	5–6
04216-06.5	.216 – .255"	5.5–6.5
04216-07	.236 – .276"	6–7
04216-07.5	.255 – .295"	6.5–7.5
04216-08	.276 – .315"	7–8
04216-08.5	.295 – .334"	7.5–8.5
04216-09	.315 – .354"	8–9
04216-09.5	.334 – .374"	8.5–9.5
04216-10	.354 – .394"	9–10
04216-10.5	.374 – .413"	9.5–10.5

ER20 Precision Metric Collets

Part No.	Inch Range	Shank
04220-01	.019 – .039"	0.5–1
04220-01.5	.039 – .059"	1.0–1.5
04220-02	.039 – .079"	1.5–2
04220-02.5	.059 – .098"	1.5–2.5
04220-03	.079 – .118"	2–3
04220-03.5	.098 – .137"	2.5–3.5
04220-04	.118 – .157"	3–4
04220-04.5	.137 – .177"	3.5–4.5
04220-05	.157 – .197"	4–5
04220-05.5	.177 – .216"	4.5–5.5
04220-06	.197 – .236"	5–6
04220-06.5	.216 – .255"	5.5–6.5
04220-07	.236 – .276"	6–7
04220-07.5	.255 – .295"	6.5–7.5
04220-08	.276 – .315"	7–8
04220-08.5	.295 – .334"	7.5–8.5
04220-09	.315 – .354"	8–9
04220-09.5	.334 – .374"	8.5–9.5
04220-10	.354 – .394"	9–10
04220-10.5	.374 – .413"	9.5–10.5
04220-11	.394 – .433"	10–11
04220-11.5	.413 – .452"	10.5–11.5
04220-12	.433 – .472"	11–12
04220-12.5	.452" – .492"	11.5–12.5
04220-13	.472 – .512"	12–13
04220-13.5	.492 – .531"	12.5–13.5
04220-14	.512 – .551"	13–14

Metric Size Precision ER Collets

ER25 Precision Metric Collets

Part No.	Inch Range	Shank mm
04225-02	.039 – .079"	1.5–2
04225-02.5	.059 – .098"	2–2.5
04225-03	.079 – .118"	2–3
04225-03.5	.098 – .137"	2.5–3.5
04225-04	.118 – .157"	3–4
04225-05	.157 – .197"	4–5
04225-06	.197 – .236"	5–6
04225-07	.236 – .276"	6–7
04225-08	.276 – .315"	7–8
04225-09	.315 – .354"	8–9
04225-10	.354 – .394"	9–10
04225-11	.394 – .433"	10–11
04225-12	.433 – .472"	11–12
04225-13	.472 – .512"	12–13
04225-14	.512 – .551"	13–14
04225-15	.551 – .591"	14–15
04225-16	.591 – .630"	15–16
04225-17	.630 – .669"	16–17

Use the table (below) for selecting your replacement collets. ER collets all have unique length and diameter measurements.

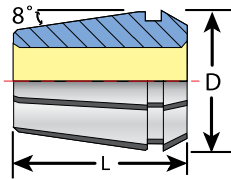

Size	L	D
ER8	13mm (.51")	8.5mm (.33")
ER11	18mm (.708")	11.5mm (.45")
ER16	27.5mm (1.08")	17mm (0.67")
ER20	31.5mm (1.24")	21mm (0.83")
ER25	34mm (1.34")	26mm (1.02")
ER32	40mm (1.57")	33mm (1.3")
ER40	46mm (1.81")	41mm (1.61")
ER50	60mm (2.36")	52mm (2.05")

ER32 Precision Metric Collets

Part No.	Inch Range	Shank mm
04232-03	.079 – .118"	2–3
04232-03.5	.098 – .137"	2.5–3.5
04232-04	.118 – .157"	3–4
04232-04.5	.137 – .177"	3.5–4.5
04232-05	.157 – .197"	4–5
04232-05.5	.177 – .216"	4.5–5.5
04232-06	.197 – .236"	5–6
04232-06.5	.216 – .255"	5.5–6.5
04232-07	.236 – .276"	6–7
04232-07.5	.255 – .295"	6.5–7.5
04232-08	.276 – .315"	7–8
04232-08.5	.295 – .334"	7.5–8.5
04232-09	.315 – .354"	8–9
04232-09.5	.334 – .374"	8.5–9.5
04232-10	.354 – .394"	9–10
04232-10.5	.374 – .413"	9.5–10.5
04232-11	.394 – .433"	10–11
04232-11.5	.413 – .452"	10.5–11.5
04232-12	.433 – .472"	11–12
04232-12.5	.452 – .492"	11.5–12.5
04232-13	.472 – .512"	12–13
04232-13.5	.492 – .531"	12.5–13.5
04232-14	.512 – .551"	13–14
04232-14.5	.531 – .570"	13.5–14.5
04232-15	.551 – .591"	14–15
04232-15.5	.570 – .610"	14.5–15.5
04232-16	.591 – .630"	15–16
04232-16.5	.610" – .649"	15.5–16.5
04232-17	.630 – .669"	16–17
04232-17.5	.649 – .688"	16.5–17.5
04232-18	.669 – .709"	17–18
04232-18.5	.688 – .728"	17.5–18.5
04232-19	.709 – .748"	18–19
04232-19.5	.728 – .767"	18.5–19.5
04232-20	.748 – .787"	19–20
04232-21	.787 – .827"	20–21

ER40 Precision Metric Collets

Part No.	Inch Range	Shank mm
04240-04	.118 – .157"	3–4
04240-05	.157 – .197"	4–5
04240-06	.197 – .236"	5–6
04240-07	.236 – .276"	6–7
04240-08	.276 – .315"	7–8
04240-09	.315 – .354"	8–9
04240-10	.354 – .394"	9–10
04240-11	.394 – .433"	10–11
04240-12	.433 – .472"	11–12
04240-13	.472 – .512"	12–13
04240-14	.512 – .551"	13–14
04240-15	.551 – .591"	14–15
04240-16	.591 – .630"	15–16
04240-17	.630 – .669"	16–17
04240-18	.669 – .709"	17–18
04240-19	.709 – .748"	18–19
04240-20	.748 – .787"	19–20
04240-21	.787 – .827"	20–21
04240-22	.827 – .866"	21–22
04240-23	.866 – .906"	22–23
04240-24	.906 – .945"	23–24
04240-25	.945 – .984"	24–25
04240-26	.984 – 1.024"	25–26

ER50 Precision Metric Collets

Part No.	Inch Range	Shank mm
04250-06	.197 – .236"	5–6
04250-07	.236 – .276"	6–7
04250-08	.276 – .315"	7–8
04250-09	.315 – .354"	8–9
04250-10	.354 – .394"	9–10
04250-12	.394 – .472"	10–12
04250-14	.472 – .551"	12–14
04250-16	.551 – .630"	14–16
04250-18	.630 – .709"	16–18
04250-20	.709 – .787"	18–20
04250-22	.787 – .866"	20–22
04250-24	.866 – .945"	22–24
04250-26	.945 – 1.024"	24–26
04250-28	1.024 – 1.102"	26–28
04250-30	1.102 – 1.181"	28–30
04250-32	1.181 – 1.259"	30–32
04250-34	1.259 – 1.338"	32–34

ETS*/DNA "Dead Nuts Accurate" ER Size Collets

Use our ETS/DNA collets and nuts for shanks 1/8" or smaller.



Features

- .0002" T.I.R. extends cutting tool life!
- Best collet for tools 1/8" (6mm) and smaller
- More rigid and more accurate than ER, but works with your ER holders

DNA 11 Dead Nuts Accurate Collets

Part No.	Shank Size inch/mm	Collapse Range inch / mm
05952-02	5/64" / 1.5 - 2mm	.059" - .079" / .5mm
05952-03	7/64" / 2.5 - 3mm	.098" - .118" / .5mm
05952-03.5	1/8" / 3 - 3.5mm	.118" - .138" / .5mm
05952-04	5/32" / 3.5 - 4mm	.138" - .157" / .5mm
05952-05	3/16" / 4.5 - 5mm	.177" - .197" / .5mm
05952-06	15/64" / 5.5 - 6mm	.216" - .236" / .5mm
05952-1/8	exact size collet: 1/8"	.105" - .125" / .5mm
05952-3/16	exact size collet: 3/16"	.167" - .187" / .5mm
05952-1/4	exact size collet: 1/4"	.230" - .250" / .5mm
2011.0000	DNA 11 nut M14 x .75"	
04608	DNA 11 collet wrench	
DNA11TWA	DNA 11 torque wrench adapter	

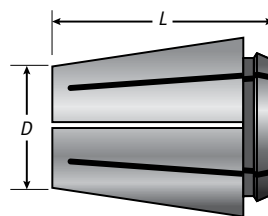
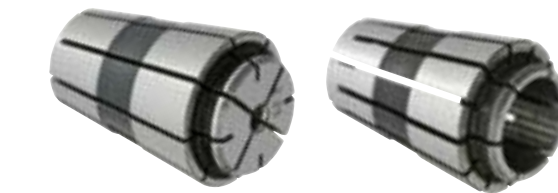

DNA Dimensions

Collet	L	D
DNA 11	.673	.460
DNA 16	.945	.654
DNA 20	1.201	.815
DNA 25	1.339	1.010
DNA 32	1.571	1.301
DNA 40	1.776	1.617

Use the table for selecting your replacement collets. ER collets all have unique length and diameter measurements.

DNA 16 Dead Nuts Accurate Collets

Part No.	Shank Size inch/mm	Range inch/mm
05954-0.3	.2 - .3mm	.007" - .011" / .10mm
05954-0.4	1/64" / .3 - .4mm	.011" - .015" / .10mm
05954-0.5	.4 - .5mm	.015" - .019" / .10mm
05954-0.6	.5 - .6mm	.019" - .023" / .10mm
05954-0.8	1/32" / .7 - .8mm	.027" - .031" / .10mm
05954-1.0	.9 - 1.0mm	.035" - .039" / .10mm
05954-1.2	3/64" / 1.1 - 1.2mm	.043" - .047" / .10mm
05954-1.25	1.0 - 1.25mm	.039" - .049" / .25mm
05954-1.5	1.25 - 1.5mm	.049" - .059" / .25mm
05954-1.75	1/16" / 1.5 - 1.75mm	.059" - .068" / .25mm
05954-02	5/64" / 1.75 - 2mm	.068" - .078" / .25mm
05954-2.25	2 - 2.25mm	.078" - .088" / .25mm
05954-2.5	3/32" / 2.25 - 2.5mm	.088" - .098" / .25mm
05954-03	2.5 - 3mm	.098" - .118" / .5mm
05954-3.5	1/8" / 3 - 3.5mm	.118" - .138" / .5mm
05954-04	5/32" / 3.5 - 4mm	.137" - .157" / .5mm
05954-4.5	4 - 4.5mm	.157" - .177" / .5mm
05954-05	3/16" / 4 - 5mm	.157" - .197" / 1.0mm
05954-06	7/32" / 5 - 6mm	.196" - .236" / 1.0mm
05954-07	1/4" / 6 - 7mm	.236" - .275" / 1.0mm
05954-08	5/16" / 7 - 8mm	.275" - .314" / 1.0mm
05954-09	11/32" / 8 - 9mm	.314" - .354" / 1.0mm
05954-10	3/8" / 9 - 10mm	.354" - .392" / 1.0mm
05954-1/8	exact size collet: 1/8"	.105" - .125" / .5mm
05954-3/16	exact size collet: 3/16"	.147" - .187" / 1.0mm
05954-1/4	exact size collet: 1/4"	.210" - .25" / 1.0mm
05954-3/8	exact size collet: 3/8"	.335 - .375" / 1.0mm

How it works

ER Collet

metal on shank

large counterbore leaves shank unsupported

DNA Collet

twice as much metal holding tool shank!

DNA collets hold small tools with greater rigidity and more accuracy (T.I.R.) for greatly improved tool life.

For Best Results Use ETS*/DNA Collets & Nuts



Coolant Rings
pg. 66

Retention Knobs
pg. 228

Wrenches
pg. 232

ETS/DNA nuts feature PowerCOAT for 75% more holding power and best tool life.

ETS/DNA 16 Nuts, Sealed Nuts, Wrenches & TWAs

Part No.	Description
2016-2000	DNA16 Mini Nut - M19 x 1.0" x O.D. 25mm
27116	M22 x 1.5 nut, , O.D. 27mm
27116-30	3.0 - 2.5mm sealed nut, O.D. 27mm
27116-40	4.0 - 3.5mm sealed nut, O.D. 27mm
27116-45	4.5 - 4.0mm sealed nut, O.D. 27mm
27116-50	5.0 - 4.5mm sealed nut, O.D. 27mm
27116-55	5.5 - 5mm sealed nut, O.D. 27mm
27116-60	6.0 - 5.5mm sealed nut, O.D. 27mm
27116-65	6.5 - 6mm sealed nut, O.D. 27mm
DNA16W	DNA 16 collet wrench
DNA16TWA	DNA 16 torque wrench adapter
894-22	DNA 16 mini nut wrench

ETS/DNA 20 Dead Nuts Accurate Collets

Part No.	Shank Size inch/mm	Range inch/mm
05956-03	2.5 - 3mm	.098" - .118" / .5mm
05956-3.5	1/8" / 3 - 3.5mm	.118" - .138" / .5mm
05956-04	5/32" / 3.5 - 4mm	.137" - .157" / .5mm
05956-05	3/16" / 4 - 5mm	.157" - .197" / 1.0mm
05956-06	7/32" 5 - 6mm	.197" - .236" / 1.0mm
05956-1/8	exact size collet: 1/8"	.105" - .125" / .5mm
05956-3/16	exact size collet: 3/16"	.147" - .187" / 1.0mm
05956-1/4	exact size collet: 1/4"	.210" - .250" / 1.0mm
05956-3/8	exact size collet: 3/8"	.335" - .375" / 1.0mm
2020.0000	DNA 20 nut, M25 x 1.5" x O.D. 32mm	
2020.0000C	DNA 20 coolant nut, uses ER20 rings on page 60	
DNA20W	DNA 20 collet wrench	
DNA20TWA	DNA 20 torque wrench adapter	

ETS/DNA 32 Dead Nuts Accurate Collets

Part No.	Shank Size inch/mm	Range inch/mm
05958-03	2.5 - 3mm	.098" - .118" / .5mm
05958-3.5	1/8" / 3 - 3.5mm	.118" - .138" / .5mm
05958-04	5/32" / 3.5 - 4mm	.137" - .157" / .5mm
05958-05	3/16" / 4 - 5mm	.157" - .197" / 1.0mm
05958-06	7/32" 5 - 6mm	.197" - .236" / 1.0mm
05958-1/8	exact size collet: 1/8"	.105" - .125" / .5mm
05958-3/16	exact size collet: 3/16"	.147" - .187" / 1.0mm
05958-1/4	exact size collet: 1/4"	.210" - .250" / 1.0mm
05958-3/8	exact size collet: 3/8"	.335" - .375" / 1.0mm
05958-1/2	exact size collet: 1/2"	.460" - .5" / 1.0mm
05958-3/4	exact size collet: 3/4"	.710" - .75" / 1.0mm
05958-13	exact size collet: 13mm	.472" - .512" / 1.0mm
05958-20	exact size collet: 20mm	.748" - .787" / 1.0mm
1132.0000	DNA 32 nut, M40 x 1.5" x O.D. 47.5mm	
1132.0000C	DNA 32 coolant nut, uses ER25 rings on page 60	
DNA32W	DNA 32 collet wrench	
DNA32TWA	DNA 32 torque wrench adapter	



*ETS compatible

Steel Sealed Precision ER Coolant Collets – Inch Size



Features

- Sealed to 2000 PSI
- No plugs to fail
- Protects toolholder from contaminants



Nuts
pg. 64



Coolant
Rings
pg. 66



Retention
Knobs
pg. 228



Wrenches
pg. 232

Designed for use with on-size tools.

Use with ER, RD, DR, ESX or BR collet chucks.



ER16 Inch Size

Part No.	Shank
04543-3/32	3/32"
04543-1/8	1/8"
04543-5/32	5/32"
04543-3/16	3/16"
04543-7/32	7/32"
04543-1/4	1/4"
04543-9/32	9/32"
04543-5/16	5/16"
04543-11/32	11/32"
04543-3/8	3/8"
04543-13/32	13/32"

Blue indicates coolant.

ER20 Inch Size

Part No.	Shank
04544-1/8	1/8"
04544-5/32	5/32"
04544-3/16	3/16"
04544-7/32	7/32"
04544-1/4	1/4"
04544-9/32	9/32"
04544-5/16	5/16"
04544-11/32	11/32"
04544-3/8	3/8"
04544-13/32	13/32"
04544-7/16	7/16"
04544-15/32	15/32"
04544-1/2	1/2"

ER25 Inch Size

Part No.	Shank
04545-7/32	7/32"
04545-1/4	1/4"
04545-9/32	9/32"
04545-5/16	5/16"
04545-11/32	11/32"
04545-3/8	3/8"
04545-13/32	13/32"
04545-7/16	7/16"
04545-15/32	15/32"
04545-1/2	1/2"
04545-17/32	17/32"
04545-9/16	9/16"
04545-19/32	19/32"
04545-5/8	5/8"

ER Inch Size Collet Sets

Part No.	Size	Pcs.	Fits Shank Sizes
04543IS	ER16	10	3/32 - 3/8"
04544IS	ER20	12	5/32 - 1/2"
04545IS	ER25	14	7/32 - 5/8"
04546IS	ER32	18	7/32 - 3/4"
04547IS	ER40	15	3/8 - 1.0"

ER32 Inch Size

Part No.	Shank
04546-7/32	7/32"
04546-1/4	1/4"
04546-9/32	9/32"
04546-5/16	5/16"
04546-11/32	11/32"
04546-3/8	3/8"
04546-13/32	13/32"
04546-7/16	7/16"
04546-15/32	15/32"
04546-1/2	1/2"
04546-17/32	17/32"
04546-9/16	9/16"
04546-19/32	19/32"
04546-5/8	5/8"
04546-21/32	21/32"
04546-11/16	11/16"
04546-23/32	23/32"
04546-3/4	3/4"

ER40 Inch Size

Part No.	Shank
04547-3/8	3/8"
04547-13/32	13/32"
04547-7/16	7/16"
04547-15/32	15/32"
04547-1/2	1/2"
04547-17/32	17/32"
04547-9/16	9/16"
04547-19/32	19/32"
04547-5/8	5/8"
04547-21/32	21/32"
04547-11/16	11/16"
04547-23/32	23/32"
04547-3/4	3/4"
04547-27/32	27/32"
04547-7/8	7/8"
04547-29/32	29/32"
04547-31/32	31/32"
04547-63/64	63/64"
04547-1	1.0"

Use our collets with our special PowerCOAT nut to reduce friction, increasing holding power by 75% compared to standard nuts. Holding power increases cutting tool life.

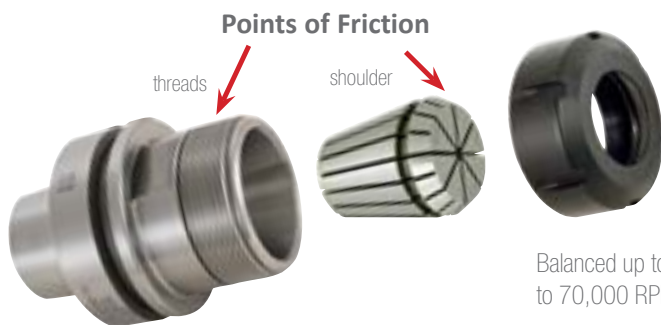

Balanced up to
to 70,000 RPMs

Steel Sealed Precision ER Coolant Collets – Metric



Features

- Sealed to 2000 PSI
- No plugs to fail
- Protects toolholder from contaminants



Nuts
pg. 64



Coolant
Rings
pg. 66



Retention
Knobs
pg. 228



Wrenches
pg. 232

Designed for use with on-size tools.

Use with ER, RD, DR, ESX or BR collet chucks.



ER16 Metric Size

Part No.	Shank
04543-03	3mm
04543-04	4mm
04543-05	5mm
04543-06	6mm
04543-07	7mm
04543-08	8mm
04543-09	9mm
04543-10	10mm

ER20 Metric Size

Part No.	Shank
04544-03	3mm
04544-04	4mm
04544-05	5mm
04544-06	6mm
04544-07	7mm
04544-08	8mm
04544-09	9mm
04544-10	10mm
04544-11	11mm
04544-12	12mm
04544-13	13mm

ER25 Metric Size

Part No.	Shank
04545-03	3mm
04545-04	4mm
04545-05	5mm
04545-06	6mm
04545-07	7mm
04545-08	8mm
04545-09	9mm
04545-10	10mm
04545-11	11mm
04545-12	12mm
04545-13	13mm
04545-14	14mm
04545-15	15mm
04545-16	16mm

ER Metric Size Collet Sets

Part No.	Size	Pcs.	Fits Shank Sizes
04543MS	ER16	8	3 - 10mm
04544MS	ER20	11	3 - 13mm
04545MS	ER25	14	3 - 16mm
04546MS	ER32	18	3 - 20mm
04547MS	ER40	16	6 - 25mm

ER32 Metric Size

Part No.	Shank
04546-03	3mm
04546-04	4mm
04546-05	5mm
04546-06	6mm
04546-07	7mm
04546-08	8mm
04546-09	9mm
04546-10	10mm
04546-11	11mm
04546-12	12mm
04546-13	13mm
04546-14	14mm
04546-15	15mm
04546-16	16mm
04546-17	17mm
04546-18	18mm
04546-19	19mm
04546-20	20mm

ER40 Metric Size

Part No.	Shank
04547-06	6mm
04547-07	7mm
04547-08	8mm
04547-09	9mm
04547-10	10mm
04547-11	11mm
04547-12	12mm
04547-13	13mm
04547-14	14mm
04547-15	15mm
04547-16	16mm
04547-17	17mm
04547-18	18mm
04547-19	19mm
04547-20	20mm
04547-25	25mm

Use our collets with our special PowerCOAT nut to reduce friction, increasing holding power by 75% compared to standard nuts. Holding power increases cutting tool life.

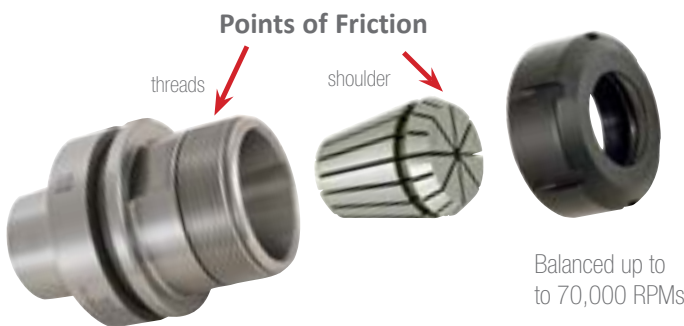

Precision ER Sealed Metric Coolant Collets



Features

- For coolant up to 750 PSI
- Use with ER PowerCOAT nuts (page 58)
- Collapse range: 0.25mm

NOTE: Inch sizes are available for ER16 & ER20.

Use with ER, RD, DR, ESX or BR collet chucks.

Blue indicates coolant.

ER16 Sealed Collets

Part No.	Shank
08316-03.0	3mm
08316-03.5	3.5mm
08316-04.0	4mm
08316-04.5	4.5mm
08316-05.0	5mm
08316-05.5	5.5mm
08316-06.0	6mm
08316-1/4	1/4"
08316-06.5	6.5mm
08316-07.0	7mm
08316-07.5	7.5mm
08316-08.0	8mm
08316-08.5	8.5mm
08316-09.0	9mm
08316-09.5	9.5mm
08316-10.0	10mm

ER25 Sealed Collets

Part No.	Shank
08325-03.0	3mm
08325-03.5	3.5mm
08325-04.0	4mm
08325-04.5	4.5mm
08325-05.0	5mm
08325-05.5	5.5mm
08325-06.0	6mm
08325-1/4	1/4"
08325-06.5	6.5mm
08325-07.0	7mm
08325-07.5	7.5mm
08325-08.0	8mm
08325-08.5	8.5mm
08325-09.0	9mm
08325-09.5	9.5mm
08325-10.0	10mm
08325-10.5	10.5mm
08325-11.0	11mm
08325-11.5	11.5mm
08325-12.0	12mm
08325-12.5	12.5mm
08325-1/2	1/2"
08325-13.0	13mm
08325-13.5	13.5mm
08325-14.0	14mm
08325-14.5	14.5mm
08325-15.0	15mm
08325-15.5	15.5mm
08325-16.0	16mm

ER32 Sealed Collets

Part No.	Shank
08332-03.0	3mm
08332-03.5	3.5mm
08332-04.0	4mm
08332-04.5	4.5mm
08332-05.0	5mm
08332-05.5	5.5mm
08332-06.0	6mm
08332-1/4	1/4"
08332-06.5	6.5mm
08332-07.0	7mm
08332-07.5	7.5mm
08332-08.0	8mm
08332-08.5	8.5mm
08332-09.0	9mm
08332-09.5	9.5mm
08332-10.0	10mm
08332-10.5	10.5mm
08332-11.0	11mm
08332-11.5	11.5mm
08332-12.0	12mm
08332-12.5	12.5mm
08332-1/2	1/2"
08332-13.0	13mm
08332-13.5	13.5mm
08332-14.0	14mm
08332-14.5	14.5mm
08332-15.0	15mm
08332-15.5	15.5mm
08332-16.0	16mm
08332-16.5	16.5mm
08332-17.0	17mm
08332-17.5	17.5mm
08332-18.0	18mm
08332-18.5	18.5mm
08332-19	19mm
08332-3/4	3/4"
08332-19.5	19.5mm
08332-20.0	20mm

ER40 Sealed Collets

Part No.	Shank
08340-06.0	6mm
08340-1/4	1/4"
08340-06.5	6.5mm
08340-07.0	7mm
08340-07.5	7.5mm
08340-08.0	8mm
08340-08.5	8.5mm
08340-09.0	9mm
08340-09.5	9.5mm
08340-10.0	10mm
08340-10.5	10.5mm
08340-11.0	11mm
08340-11.5	11.5mm
08340-12.0	12mm
08340-12.5	12.5mm
08340-1/2	1/2"
08340-13.0	13mm
08340-13.5	13.5mm
08340-14.0	14mm
08340-14.5	14.5mm
08340-15.0	15mm
08340-15.5	15.5mm
08340-16.0	16mm
08340-16.5	16.5mm
08340-17.0	17mm
08340-17.5	17.5mm
08340-18.0	18mm
08340-18.5	18.5mm
08340-19.0	19mm
08340-3/4	3/4"
08340-19.5	19.5mm
08340-20.0	20mm
08340-20.5	20.5mm
08340-21.0	21mm
08340-21.5	21.5mm
08340-22.0	22mm
08340-22.5	22.5mm
08340-23.0	23mm
08340-23.5	23.5mm
08340-24.0	24mm
08340-24.5	24.5mm
08340-25.0	25mm
08340-25.5	25.5mm
08340-26.0	26mm
08340-1	1" / 25.4mm

ER20 Sealed Collets

Part No.	Shank
08320-03.0	3mm
08320-03.5	3.5mm
08320-04.0	4mm
08320-04.5	4.5mm
08320-05.0	5mm
08320-05.5	5.5mm
08320-06.0	6mm
08320-1/4	1/4"
08320-06.5	6.5mm
08320-07.0	7mm
08320-07.5	7.5mm
08320-08.0	8mm
08320-08.5	8.5mm
08320-09.0	9mm
08320-09.5	9.5mm
08320-10.0	10mm
08320-10.5	10.5mm
08320-11.0	11mm
08320-11.5	11.5mm
08320-12.0	12mm
08320-12.5	12.5mm
08320-1/2	1/2"
08320-13.0	13mm

Sealed Collet Sets



Part No.	Description
08316MS	15 pcs. ER16
08320MS	21 pcs ER20
08325MS	27 pcs ER25
08332-35MS	35 pcs ER32
08340-41MS	41 pcs ER40

Precision ER Floating Tap Collets and Collet Sets



Features

- Axial compensation prevents breaking taps
- Replaces expensive tapping heads
- Locking feature prevents spinning the tap
- Reduce tapping clearance requirements

Applications: CNC lathes, VDI turrets, angle heads, CNC machine center, swiss style turning machines, and driven heads on CNC lathe turrets.

Simply program the machine 5% behind the recommended pitch feed of the tap to make the floating collet work. Return out of the tapped hole at 100%.

For best performance use FT tap collets with Techniks PowerCOAT nut. See page 58.

Compatible with these standard collet chucks:
ER, DR, RD, ESX, BR or DIN 6499 collet pockets.



Nuts
pg. 64



Coolant
Rings
pg. 66



Retention
Knobs
pg. 228



Wrenches
pg. 232

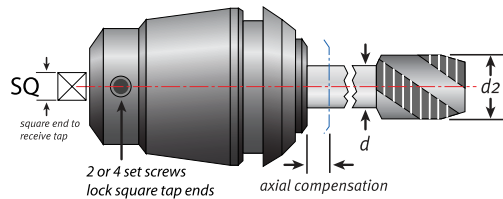

FT Collet Sets

Part No.	Description
05916IS	4 piece FT-116 collet set
05920IS	5 piece FT-120 collet set
05925IS	9 piece FT-125 collet set
05932IS	11 piece FT-132 collet set

FT-116 Floating Tap Collets

Part No.	d	SQ	Size (d2)
05916-141	.141"	.110"	1/8" or #6
05916-168	.168"	.131"	5/32" or #8
05916-194	.194"	.152"	3/16" or #10
05916-220	.220"	.165"	7/32" or #12

axial compensation = 7mm

FT-125 Floating Tap Collets

Part No.	d	SQ	Size (d2)
05925-141	.141"	.110"	1/8" or #6
05925-168	.168"	.131"	5/32" or #8
05925-194	.194"	.152"	3/16" or #10
05925-220	.220"	.165"	7/32" or #12
05925-255	.255"	.191"	1/4"
05925-318	.318"	.238"	5/16"
05925-323	.323"	.242"	7/16"
05925-367	.367"	.275"	1/2"
05925-381	.381"	.286"	3/8"

axial compensation = 8mm

FT-132 Floating Tap Collets

Part No.	d	SQ	Size (d2)
05932-168	.168"	.131"	5/32" or #8
05932-194	.194"	.152"	3/16" or #10
05932-220	.220"	.165"	7/32" or #12
05932-255	.255"	.191"	1/4"
05932-318	.318"	.238"	5/16"
05932-323	.323"	.242"	7/16"
05932-367	.367"	.275"	1/2"
05932-381	.381"	.286"	3/8"
05932-429	.429"	.322"	9/16"
05932-437	.437"	.328"	1/8" NPT
05932-480	.480"	.360"	5/8"

axial compensation = 10mm

FT-120 Floating Tap Collets

Part No.	d	SQ	Size (d2)
05920-141	.141"	.110"	1/8" or #6
05920-168	.168"	.131"	5/32" or #8
05920-194	.194"	.152"	3/16" or #10
05920-220	.220"	.165"	7/32" or #12
05920-255	.255"	.191"	1/4"

axial compensation = 7mm



Precision ER Rigid Tap Collets Inch Sizes

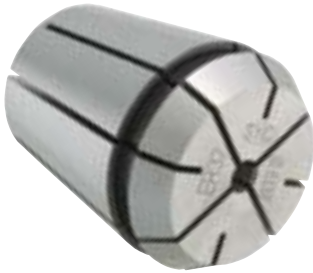

Features

- Replaces expensive tap holders
- Reduce tapping clearance requirements
- Special design locks square in slots

Compatible with ER, DR, RD, ESX, BR or DIN 6499 collet pockets.

For best results use with a PowerCOAT nut to increase clamping pressure up to 75%. See page 64.

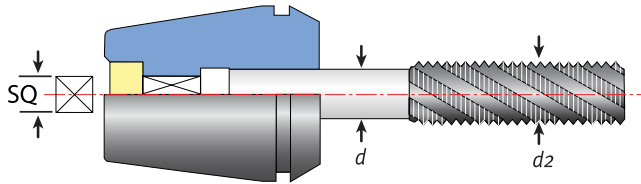

ER32 Rigid Tap Collets

Part No.	d	SQ	Tap Size (d2)
05570-141	.141"	.110"	1/8" or #6
05570-168	.168"	.131"	5/32" or #8
05570-194	.194"	.152"	3/16" or #10
05570-220	.220"	.165"	7/32" or #12
05570-255	.255"	.191"	1/4"
05570-318	.318"	.238"	5/16"
05570-323	.323"	.242"	7/16"
05570-367	.367"	.275"	1/2"
05570-381	.381"	.286"	3/8"
05570-429	.429"	.322"	9/16"
05570-437	.437"	.328"	1/8" NPT
05570-480	.480"	.360"	5/8"
05570-542	.542"	.406"	11/16"
05570-562	.562"	.421"	1/4" NPT
05570-590	.590"	.442"	3/4"
05570-652	.652"	.489"	13/16"

ER16 Rigid Tap Collets

Part No.	d	SQ	Tap Size (d2)
05320-141	.141"	.110"	1/8" or #6
05320-168	.168"	.131"	5/32" or #8
05320-194	.194"	.152"	3/16" or #10
05320-220	.220"	.165"	7/32" or #12
05320-255	.255"	.191"	1/4"
05320-318	.318"	.238"	5/16"
05320-323	.323"	.242"	7/16"
05320-367	.367"	.275"	1/2"
05320-381	.381"	.286"	3/8"

ER25 Rigid Tap Collets

Part No.	d	SQ	Tap Size (d2)
05510-141	.141"	.110"	1/8" or #6
05510-168	.168"	.131"	5/32" or #8
05510-194	.194"	.152"	3/16" or #10
05510-220	.220"	.165"	7/32" or #12
05510-255	.255"	.191"	1/4"
05510-318	.318"	.238"	5/16"
05510-323	.323"	.242"	7/16"
05510-367	.367"	.275"	1/2"
05510-381	.381"	.286"	3/8"
05510-429	.429"	.322"	9/16"
05510-437	.437"	.328"	1/8" NPT
05510-480	.480"	.360"	5/8"
05510-542	.542"	.406"	11/16"

ER40 Rigid Tap Collets

Part No.	d	SQ	Tap Size (d2)
05710-141	.141"	.110"	1/8" or #6
05710-168	.168"	.131"	5/32" or #8
05710-194	.194"	.152"	3/16" or #10
05710-220	.220"	.165"	7/32" or #12
05710-255	.255"	.191"	1/4"
05710-318	.318"	.238"	5/16"
05710-323	.323"	.242"	7/16"
05710-367	.367"	.275"	1/2"
05710-381	.381"	.286"	3/8"
05710-429	.429"	.322"	9/16"
05710-437	.437"	.328"	1/8" NPT
05710-480	.480"	.360"	5/8"
05710-542	.542"	.406"	11/16"
05710-562	.562"	.421"	1/4" NPT
05710-590	.590"	.442"	3/4"
05710-652	.652"	.489"	13/16"
05710-687	.687"	.515"	1/2" NPT
05710-697	.697"	.523"	7/8"
05710-700	.700"	.531"	3/8" NPT
05710-760	.760"	.570"	15/16"
05710-800	.800"	.600"	1"

ER20 Rigid Tap Collets

Part No.	d	SQ	Tap Size (d2)
05410-141	.141"	.110"	1/8" or #6
05410-168	.168"	.131"	5/32" or #8
05410-194	.194"	.152"	3/16" or #10
05410-220	.220"	.165"	7/32" or #12
05410-255	.255"	.191"	1/4"
05410-318	.318"	.238"	5/16"
05410-323	.323"	.242"	7/16"
05410-367	.367"	.275"	1/2"
05410-381	.381"	.286"	3/8"

Rigid Tap Collet Sets



Part No.	Description
05320-5(SET)	5 piece ER16 set
05320-9(SET)	9 piece ER16 set
05410-9(SET)	9 piece ER20 set
05510-11(SET)	11 piece ER25 set
05570-16(SET)	16 piece ER32 set
05710-21(SET)	21 piece ER40 set

Precision ER Rigid Tap Collets Metric Sizes



- Replaces expensive tap holders
- Reduce tap clearance requirements
- Special design locks square in slots

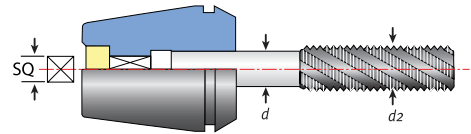

ER16 Rigid Tap Collets

Part No.	d	SQ	Tap Size (d2)
05326-DIN	2.8	2.1	M4
05330-DIN	3.5	2.7	M3
05336-DIN	4.5	3.4	M4
05342-DIN	6	4.9	M5/M6
05350-DIN	8	6.2	M8
05352	8.5	6.5	M12
05354-DIN	9	7	M12
05356-DIN	10	8	M10
05371	6	4.5	M6
05385	6.2	5	M8



Nuts
pg. 64



Coolant
Rings
pg. 66



Retention
Knobs
pg. 228



Wrenches
pg. 232

ER32 Rigid Tap Collets

Part No.	d	SQ	Tap Size (d2)
05572	2.25	1.8	M3
05574	2.5	2	M3.5
05576	2.8	2.1	M4
05578	3.14	2.5	M3/M4
05580	3.5	2.7	M3/M5
05582	3.55	2.8	M3.5/M4.5
05584	4	3	M3/M5
05586-DIN	4.5	3.4	M4/M6
05588	5	5	M4/M5
05590	5.5	4.5	M5/M5.5
05592-DIN	6	4.5	M5/M8
05594	6.2	5	M7/M8
05596	6.3	5	M6/M8
05598-M9	7	5.5	M9/M10
05600-DIN	8	6	M8/M11
05602	8.5	6.5	M12
05604-DIN	9	7	M12
05606-DIN	10	8	M10
05608	10.5	8	M14
05610	11	9	M14
05612	11.2	9	M14
05614-DIN	12	9	M16
05616	12.5	10	M16
05618	13	10	M17
05620-DIN	14	11	M18/M20
05622	15	12	M20
05624-DIN	16	12	M20/M22
05626	17	13	M22
05628	18	14	M22/M24
05630	19	15	M24/M25
05632	20	15	M26/M27

ER40 Rigid Tap Collets

Part No.	d	SQ	Tap Size (d2)
05712	2.24	1.88	M3
05714	2.5	1	M3.5
05716	2.8	2.1	M4
05718	3.15	2.5	M3/M4
05720	3.5	2.7	M3/M5
05722	3.55	2.8	M3.5/M4.5
05724	4	3	M3/M5
05726	4.5	3.4	M4/M6
05728	5	4	M4/M5
05730	4.5	4.5	M5/M5.5
05732	6	4.5	M5/M8
05734	6.2	5	M7/M8
05736	6.3	5	M6/M8
05738	7	5.5	M10
05740	8	6	M8/M11
05742	8.5	6.5	M12
05744	9	7	M12
05746	10	8	M10
05748	10.5	8	M14
05750	11	9	M14
05752	11.2	9	M14
05754	12	9	M16
05756	12.5	10	M16
05758	13	10	M17
05760	14	11	M18/M20
05762	15	12	M20
05764	16	12	M20/M22
05766	17	13	M22
05768	18	14	M22/M24
05770	19	14	M24/M25
05772	20	20	M26/M27

ER20 Rigid Tap Collets

Part No.	d	SQ	Tap Size (d2)
05428-DIN	4.5	3.4	M4
05434-DIN	6	4.9	M5/M6
05442-DIN	8	6.2	M8
05446-DIN	9	7	M12
05448-DIN	10	8	M10
05456-DIN	12	9	M16

ER25 Rigid Tap Collets

Part No.	d	SQ	Tap Size (d2)
05526-DIN	4.5	3.4	M4
05534-DIN	6	4.9	M5/M6
05540-DIN	7	5.5	M10
05542-DIN	8	6.2	M8
05548-DIN	9	7	M12
05550	10	8	M10
05550-DIN	10	8	M10
05554-DIN	11	9	M14
05558-DIN	12	9	M16
05560	12.5	10	M16
05562	13	10	M17
05564	14	11	M18/M20
05566	15	12	M20
05568	16	12	M20/M22

Rigid Tap Collet Set



Part No.	Description
05699-11SET	11 piece Rigid Tap set

Precision ER Quick-Change Rigid Tap Collets



Features

- Quick-Change taps in seconds
- Replaces expensive tap holders
- Locking feature prevents spinning the tap
- Reduce tapping clearance requirements

Compatible with these standard collet chucks:
ER, DR, RD, ESX, BR or DIN 6499 collet pockets.

For best tapping performance use with Techniks PowerCOAT nut for highest holding power and accuracy. See page 64.

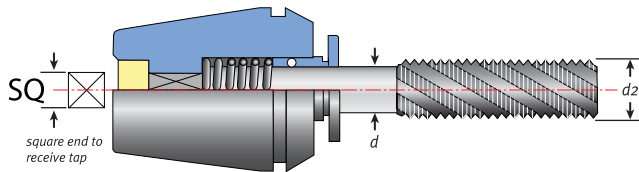

Quick-Change Tap Collet Sets

Part No.	Description
05802-4IS	4 piece ER16 collet set
05804-8IS	8 piece ER20 collet set
0580611IS	11 piece ER25 collet set
05808-15IS	15 piece ER32 collet set

ER16 Quick-Change Rigid Tap

Part No.	d	SQ	Tap Size (d2)
05802-168	.168"	.131"	5/32" or #8
05802-194	.194"	.152"	3/16" or #10
05802-220	.220"	.165"	7/32" or #12
05802-255	.255"	.191"	1/4"

ER25 Quick-Change Rigid Tap

Part No.	d	SQ	Tap Size (d2)
05806-168	.168"	.131"	5/32" or #8
05806-194	.194"	.152"	3/16" or #10
05806-220	.220"	.165"	7/32" or #12
05806-255	.255"	.191"	1/4"
05806-318	.318"	.238"	5/16"
05806-323	.323"	.242"	7/16"
05806-367	.367"	.275"	1/2"
05806-381	.381"	.286"	3/8"
05806-429	.429"	.322"	9/16"
05806-437	.437"	.328"	1/8" NPT
05806-480	.480"	.360"	5/8"

ER32 Quick-Change Rigid Tap

Part No.	d	SQ	Tap Size (d2)
05808-168	.168"	.131"	5/32" or #8
05808-194	.194"	.152"	3/16" or #10
05808-220	.220"	.165"	7/32" or #12
05808-255	.255"	.191"	1/4"
05808-318	.318"	.238"	5/16"
05808-323	.323"	.242"	7/16"
05808-367	.367"	.275"	1/2"
05808-381	.381"	.286"	3/8"
05808-429	.429"	.322"	9/16"
05808-437	.437"	.328"	1/8" NPT
05808-480	.480"	.360"	5/8"
05808-542	.542"	.406"	11/16"
05808-562	.562"	.421"	1/4" NPT
05808-590	.590"	.442"	3/4"
05808-652	.652"	.489"	13/16"

ER20 Quick-Change Rigid Tap

Part No.	d	SQ	Tap Size (d2)
05804-168	.168"	.131"	5/32" or #8
05804-194	.194"	.152"	3/16" or #10
05804-220	.220"	.165"	7/32" or #12
05804-255	.255"	.191"	1/4"
05804-318	.318"	.238"	5/16"
05804-323	.323"	.242"	7/16"
05804-367	.367"	.275"	1/2"
05804-381	.381"	.286"	3/8"

ER, TG, DA Collet Storage Trays



Features

- Prevent accidental damage to collets
- Keep collets organized and ready to use
- Exact fit for all your collets



ER Collet Storage Trays

Part No.	Description
04282	ER8 wood tray - 9 pcs.
04284	ER11 wood tray - 13 pcs.
04286	ER16 wood tray - 10 pcs.
04286-12	ER16 wood tray - 12 pcs.
04288	ER20 wood tray - 12 pcs.
04290	ER25 wood tray - 16 pcs.
04292	ER32 wood tray - 18 pcs.
04292-22	ER32 wood tray - 22 pcs.
04294	ER40 wood tray - 24 pcs.
04294-13	ER40 wood tray - 13 pcs.
04296	ER50 wood tray - 12 pcs.

DA Collet Storage Trays

Part No.	Description
04448	DA100 wood tray - 33 pcs.
04449	DA100 wood tray - 8 pcs.
04450	DA100 wood tray - 15 pcs.
04451	DA100 wood tray - 21 pcs.
04452	DA100 wood tray - 29 pcs.
04453	DA180 wood tray - 9 pcs.
04454	DA180 wood tray - 17 pcs.
04455	DA180 wood tray - 21 pcs.
04456	DA180 wood tray - 33 pcs.
04457	DA180 wood tray - 41 pcs.
04459	DA200 wood tray - 9 pcs.
04460	DA200 wood tray - 21 pcs.
04461	DA200 wood tray - 17 pcs.
04462	DA300 wood tray - 7 pcs.
04464	DA300 wood tray - 14 pcs.

TG Collet Storage Trays

Part No.	Description
04466	TG75 wood tray - 11 pcs.
04468	TG75 wood tray - 22 pcs.
04470	TG75 wood tray - 43 pcs.
04472	TG100 wood tray - 15 pcs.
04474	TG100 wood tray - 21 pcs.
04476	TG100 wood tray - 30 pcs.
04478	TG100 wood tray - 41 pcs.
04480	TG100 wood tray - 59 pcs.
04482	TG150 wood tray - 17 pcs.
04484	TG150 wood tray - 33 pcs.
04486	TG150 wood tray - 65 pcs.

PowerCOAT ER Collet Nuts and Coolant Nuts



Features

- Increases holding power by 75%
- Balanced to 25,000 RPM
- Better rigidity and T.I.R. (runout)

See Torque Chart on page 48.

PowerCOAT ER Collet Nuts

Part No.	Description	D	B	T	Wrench
41111	ER11 PowerCOAT hex nut	19mm	12mm	M14 x 0.75	04608
41116	ER16 PowerCOAT hex nut	27.5mm	18mm	M22 x 1.5	04609
41120	ER20 PowerCOAT hex nut	34mm	19mm	M25 x 1.5	04610
41916	ER16 PowerCOAT slot nut	32mm	18mm	M22 x 1.5	04613
41920	ER20 PowerCOAT slot nut	35mm	19.5mm	M25 x 1.5	04614
41925	ER25 PowerCOAT slot nut	42mm	21mm	M32 x 1.5	04615
41925-L	ER25 PowerCOAT slot nut L	42mm	21mm	M32 x 1.5	04615
41932	ER32 PowerCOAT slot nut	50mm	23mm	M40 x 1.5	04616
41940	ER40 PowerCOAT slot nut	63mm	26mm	M50 x 1.5	04617
41950	ER50 PowerCOAT slot nut	78mm	35mm	M64 x 2.0	04618

L = Left threaded

PowerCOAT Ultra High-Speed ER Nuts

(balanced up to 70,000 RPM)

Part No.	Description	D	B	T	Wrench
46111	ER11 high speed hex nut	19mm	11.8mm	M14 x 0.75	04608
46116	ER16 high speed slot nut	27.5mm	18.0mm	M22 x 1.5	04613
46120	ER20 high speed slot nut	35mm	19.5mm	M25 x 1.5	04614
46125	ER25 high speed slot nut	42mm	20.5mm	M32 x 1.5	04615
46132	ER32 high speed slot nut	50mm	23.0mm	M40 x 1.5	04616
46140	ER40 high speed slot nut	63mm	26.0mm	M50 x 1.5	04617



Features

- Increases holding power by 75%
- Seals up to 1,500 P.S.I.
- Balanced to 25,000 RPM
- Use with coolant rings pg. 60

PowerCOAT ER Coolant Nuts

Part No.	Description	D	B	T	Wrench
41616	ER16 coolant slot nut	32	22.5	M22x1.5	04613
41620	ER20 coolant slot nut	35	24	M25x1.5	04614
41625	ER25 coolant slot nut	42	25	M32x1.5	04615
41632	ER32 coolant slot nut	50	27.5	M40x1.5	04616
41640	ER40 coolant slot nut	63	30.7	M50x1.5	04617

Holding Power Testing – ft/lbs

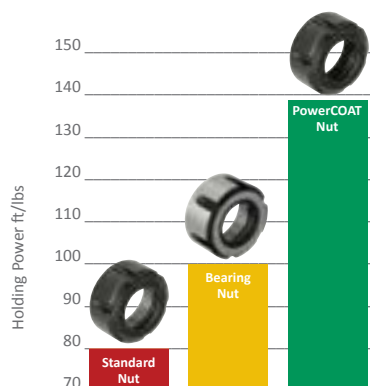

Each nut was tightened to 70 ft/lbs recommended torque before break-free testing of holding power.

Watch the Holding Power testing video at:
<http://ow.ly/sV3UY>

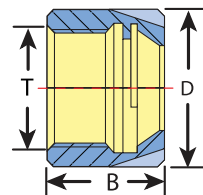

For best performance use a torque wrench and tighten nut to proper torque specification. Snap collet into nut before assembly.

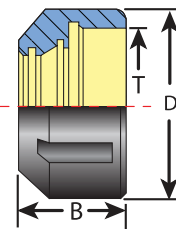

Coolant ring snaps into the nut to seal the tool shank. (pg. 60)
For coolant-thru tools.

PowerCOAT ER Mini Nuts



ER Mini Nut

Features

- For minimum nose O.D. applications
- High speed nuts balanced to 20,000 RPM
- Increases holding power by 75%



Collets
pg. 44



Coolant
Rings
pg. 66



Retention
Knobs
pg. 228



Wrenches
pg. 232

PowerCOAT ER High Speed Mini Nuts

(balanced to 20,000 RPM at G2.5)

Part No.	Description	D	B	T	Wrench
33108	ER8 high speed mini nut	12mm	11mm	M10 x 0.75	04620
33111	ER11 high speed mini nut	16mm	12mm	M13 x 0.75	04621
33116	ER16 high speed mini nut	22mm	18mm	M19 x 1.0	04622
33120	ER20 high speed mini nut	28mm	19.5mm	M24 x 1.0	04623
33125	ER25 high speed mini nut	35mm	21mm	M30 x 1.0	04624
33125-L	ER25 high speed left-hand mini nut	35mm	21mm	M30 x 1.0	04624

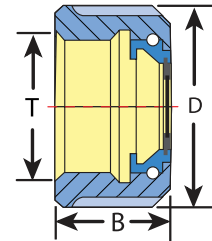

PowerCOAT ER Mini Nuts

(balanced to 10,000 RPM at G2.5)

Part No.	Description	D	B	T	Wrench
23108	ER8 mini nut	12mm	11mm	M10 x 0.75	04620
23111	ER11 mini nut	16mm	12mm	M13 x 0.75	04621
23116	ER16 mini nut	22mm	18mm	M19 x 1.0	04622
23120	ER20 mini nut	28mm	19.5mm	M24 x 1.0	04623
23125	ER25 mini nut	35mm	21mm	M30 x 1.0	04624

PowerCOAT ER Mini Coolant Nuts

(balanced to 10,000 RPM at G2.5)

Part No.	Description	Ring	D	B	T	Wrench
23616	ER16 mini coolant nut	ER16	22mm	24mm	M19 x 1.0	04622
23620	ER20 mini coolant nut	ER20	28mm	24mm	M24 x 1.0	04623
23625	ER25 mini coolant nut	ER25	35mm	26.5mm	M30 x 1.0	04624



Coolant Style Mini nut uses ER coolant rings
(page 60)

Black Gold ER Coolant Rings



Snap ring into nut before ER collet

Features

- Seals up to 1,500 P.S.I.
- Use with ER collets
- Use with PowerCOAT coolant nuts



PowerCOAT coolant nuts pg. 64.

NOTE: Remove o-ring for coolant surround tool applications using non-coolant cutting tools. (see photos next page)

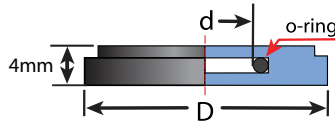

Black Gold ER16 Coolant Rings

Part No.	Shank mm	Shank inch
08516-03.5	3.5 – 3.0mm	1/8"
08516-04.0	4.0 – 3.5mm	5/32"
08516-04.5	4.5 – 4.0mm	11/64"
08516-05.0	5.0 – 4.5mm	3/16"
08516-05.5	5.5 – 5.0mm	13/64"
08516-06.0	6.0 – 5.5mm	7/32"
08516-06.5	6.5 – 6.0mm	1/4"
08516-07.0	7.0 – 6.5mm	17/64"
08516-07.5	7.5 – 7.0mm	9/32"
08516-08.0	8.0 – 7.5mm	5/16"
08516-08.5	8.5 – 8.0mm	21/64"
08516-09.0	9.0 – 8.5mm	11/32"
08516-09.5	9.5 – 9.0mm	3/8"
08516-10.0	10.0 – 9.5mm	25/64"

Dimensions	D
ER16	12.9 mm
ER20	15.9 mm
ER25	21 mm
ER32	26.95 mm
ER40	33.3 mm

Black Gold ER32 TG100 Coolant Rings

Part No.	Shank mm	Shank inch
08532-03.5	3.5 – 3.0mm	1/8"
08532-04.0	4.0 – 3.5mm	5/32"
08532-04.5	4.5 – 4.0mm	11/64"
08532-05.0	5.0 – 4.5mm	3/16"
08532-05.5	5.5 – 5.0mm	13/64"
08532-06.0	6.0 – 5.5mm	7/32"
08532-06.5	6.5 – 6.0mm	1/4"
08532-07.0	7.0 – 6.5mm	17/64"
08532-07.5	7.5 – 7.0mm	9/32"
08532-08.0	8.0 – 7.5mm	5/16"
08532-08.5	8.5 – 8.0mm	21/64"
08532-09.0	9.0 – 8.5mm	11/32"
08532-09.5	9.5 – 9.0mm	3/8"
08532-10.0	10.0 – 9.5mm	25/64"
08532-10.5	10.5 – 10.0mm	13/32"
08532-11.0	11.0 – 10.5mm	27/64"
08532-11.5	11.5 – 11.0mm	7/16"
08532-12.0	12.0 – 11.5mm	15/32"
08532-12.5	12.5 – 12.0mm	31/64"
08532-13.0	13.0 – 12.5mm	1/2"
08532-13.5	13.5 – 13.0mm	17/32"
08532-14.0	14.0 – 13.5mm	35/64"
08532-14.5	14.5 – 14.0mm	9/16"
08532-15.0	15.0 – 14.5mm	37/64"
08532-15.5	15.5 – 15.0mm	19/32"
08532-16.0	16.0 – 15.5mm	5/8"
08532-16.5	16.5 – 16.0mm	41/64"
08532-17.0	17.0 – 16.5mm	21/32"
08532-17.5	17.5 – 17.0mm	11/16"
08532-18.0	18.0 – 17.5mm	45/64"
08532-18.5	18.5 – 18.0mm	23/32"
08532-19.0	19.0 – 18.5mm	3/4"
08532-19.5	19.5 – 19.0mm	49/64"
08532-20.0	20.0 – 19.5mm	25/32"

Black Gold ER25 Coolant Rings

Part No.	Shank mm	Shank inch
08525-03.5	3.5 – 3.0mm	1/8"
08525-04.0	4.0 – 3.5mm	5/32"
08525-04.5	4.5 – 4.0mm	11/64"
08525-05.0	5.0 – 4.5mm	3/16"
08525-05.5	5.5 – 5.0mm	13/64"
08525-06.0	6.0 – 5.5mm	7/32"
08525-06.5	6.5 – 6.0mm	1/4"
08525-07.0	7.0 – 6.5mm	17/64"
08525-07.5	7.5 – 7.0mm	9/32"
08525-08.0	8.0 – 7.5mm	5/16"
08525-08.5	8.5 – 8.0mm	21/64"
08525-09.0	9.0 – 8.5mm	11/32"
08525-09.5	9.5 – 9.0mm	3/8"
08525-10.0	10.0 – 9.5mm	25/64"
08525-10.5	10.5 – 10.0mm	13/32"
08525-11.0	11.0 – 10.5mm	27/64"
08525-11.5	11.5 – 11.0mm	7/16"
08525-12.0	12.0 – 11.5mm	15/32"
08525-12.5	12.5 – 12.0mm	31/64"
08525-13.0	13.0 – 12.5mm	1/2"
08525-13.5	13.5 – 13.0mm	17/32"
08525-14.0	14.0 – 13.5mm	35/64"
08525-14.5	14.5 – 14.0mm	9/16"
08525-15.0	15.0 – 14.5mm	37/64"
08525-15.5	15.5 – 15.0mm	19/32"
08525-16.0	16.0 – 15.5mm	5/8"

Black Gold ER20 Coolant Rings

Part No.	Shank mm	Shank inch
08520-03.5	3.5 – 3.0mm	1/8"
08520-04.0	4.0 – 3.5mm	5/32"
08520-04.5	4.5 – 4.0mm	11/64"
08520-05.0	5.0 – 4.5mm	3/16"
08520-05.5	5.5 – 5.0mm	13/64"
08520-06.0	6.0 – 5.5mm	7/32"
08520-06.5	6.5 – 6.0mm	1/4"
08520-07.0	7.0 – 6.5mm	17/64"
08520-07.5	7.5 – 7.0mm	9/32"
08520-08.0	8.0 – 7.5mm	5/16"
08520-08.5	8.5 – 8.0mm	21/64"
08520-09.0	9.0 – 8.5mm	11/32"
08520-09.5	9.5 – 9.0mm	3/8"
08520-10.0	10.0 – 9.5mm	25/64"
08520-10.5	10.5 – 10.0mm	13/32"
08520-11.0	11.0 – 10.5mm	27/64"
08520-11.5	11.5 – 11.0mm	7/16"
08520-12.0	12.0 – 11.5mm	15/32"
08520-12.5	12.5 – 12.0mm	31/64"
08520-13.0	13.0 – 12.5mm	1/2"

Blue indicates coolant.

Black Gold ER Coolant Rings



Use ER Coolant Rings with o-ring for coolant-thru cutting tools.



Removing the o-ring creates a CoolBLAST coolant effect.

Use Black Gold Rings for Coolant Applications

It costs less money to use coolant rings and standard collets than coolant collets.

	ER32 Coolant Collet	ER32 Coolant Ring System
Cost of 320 collets	\$16,000.00	\$8,640.00
Cost of 20 nuts	\$ 0.00 (supplied with holders)	\$1,300.00 (includes rings)
Total 4 year cost	\$16,000.00	\$9,940.00

\$6,060.00 savings

Figures based on 20 toolholders, allowing 4 collets a year for each toolholder for a total of 320 collets, plus one nut for each toolholder over the four year period.

ER coolant rings are great for un-attended operation. There are no rubber seals to fail under high pressure.

ER Coolant Ring Sets

Part No.	Description
08516-14(SET)	14 piece ER16 coolant ring set
08520-20(SET)	20 piece ER20 coolant ring set
08525-26(SET)	26 piece ER25 coolant ring set
08532-34(SET)	34 piece ER32 coolant ring set
08540-46(SET)	46 piece ER40 coolant ring set

Black Gold ER40 Coolant Rings

Part No.	Shank mm	Shank inch
08540-03.5	3.5 – 3.0mm	1/8"
08540-04.0	4.0 – 3.5mm	5/32"
08540-04.5	4.5 – 4.0mm	11/64"
08540-05.0	5.0 – 4.5mm	3/16"
08540-05.5	5.5 – 5.0mm	13/64"
08540-06.0	6.0 – 5.5mm	7/32"
08540-06.5	6.5 – 6.0mm	1/4"
08540-07.0	7.0 – 6.5mm	17/64"
08540-07.5	7.5 – 7.0mm	9/32"
08540-08.0	8.0 – 7.5mm	5/16"
08540-08.5	8.5 – 8.0mm	21/64"
08540-09.0	9.0 – 8.5mm	11/32"
08540-09.5	9.5 – 9.0mm	3/8"
08540-10.0	10.0 – 9.5mm	25/64"
08540-10.5	10.5 – 10.0mm	13/32"

Part No.	Shank mm	Shank inch
08540-11.0	11.0 – 10.5mm	27/64"
08540-11.5	11.5 – 11.0mm	7/16"
08540-12.0	12.0 – 11.5mm	15/32"
08540-12.5	12.5 – 12.0mm	31/64"
08540-13.0	13.0 – 12.5mm	1/2"
08540-13.5	13.5 – 13.0mm	17/32"
08540-14.0	14.0 – 13.5mm	35/64"
08540-14.5	14.5 – 14.0mm	9/16"
08540-15.0	15.0 – 14.5mm	37/64"
08540-15.5	15.5 – 15.0mm	19/32"
08540-16.0	16.0 – 15.5mm	5/8"
08540-16.5	16.5 – 16.0mm	41/64"
08540-17.0	17.0 – 16.5mm	21/32"
08540-17.5	17.5 – 17.0mm	11/16"
08540-18.0	18.0 – 17.5mm	45/64"
08540-18.5	18.5 – 18.0mm	23/32"

Part No.	Shank mm	Shank inch
08540-19.0	19.0 – 18.5mm	3/4"
08540-19.5	19.5 – 19.0mm	49/64"
08540-20.0	20.0 – 19.5mm	25/32"
08540-20.5	20.5 – 20.0mm	51/64"
08540-21.0	21.0 – 20.5mm	13/16"
08540-21.5	21.5 – 21.0mm	27/32"
08540-22.0	22.0 – 21.5mm	55/64"
08540-22.5	22.5 – 22.0mm	7/8"
08540-23.0	23.0 – 22.5mm	29/32"
08540-23.5	23.5 – 23.0mm	59/64"
08540-24.0	24.0 – 23.5mm	15/16"
08540-24.5	24.5 – 24.0mm	61/64"
08540-25.0	25.0 – 24.5mm	31/32"
08540-25.5	25.5 – 25.0mm	1.0"
08540-26.0	26.0 – 25.5mm	1 1/64"

Blue indicates coolant.



Precision TG75 Collets and PowerCOAT Nut



Features

- .0004" T.I.R.
- Precision ground & hand inspected
- Clamping range: 1/64"



Dimensions

Series	L	A
TG75	1.844"	1.062"

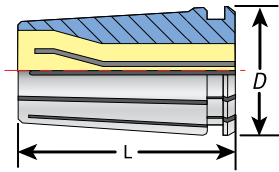

TG75 Sets

Part No.	Pieces	ID Sizes
04008-43S	43	1/8" - 3/4" by 64ths
04008-22S	22	1/8" - 3/4" by 32nds
04008-11S	11	1/8" - 3/4" by 16ths

TG75 Collets

Part No.	Shank	Part No.	Shank	Part No.	Shank	Part No.	Shank
04008-3/32	3/32"	04008-17/64	17/64"	04008-7/16	7/16"	04008-39/64	39/64"
04008-7/64	7/64"	04008-9/32	9/32"	04008-29/64	29/64"	04008-5/8	5/8"
04008-1/8	1/8"	04008-19/64	19/64"	04008-15/32	15/32"	04008-41/64	41/64"
04008-9/64	9/64"	04008-5/16	5/16"	04008-31/64	31/64"	04008-21/32	21/32"
04008-5/32	5/32"	04008-21/64	21/64"	04008-1/2	1/2"	04008-43/64	43/64"
04008-11/64	11/64"	04008-11/32	11/32"	04008-33/64	33/64"	04008-11/16	11/16"
04008-3/16	3/16"	04008-23/64	23/64"	04008-17/32	17/32"	04008-45/64	45/64"
04008-13/64	13/64"	04008-3/8	3/8"	04008-35/64	35/64"	04008-23/32	23/32"
04008-7/32	7/32"	04008-25/64	25/64"	04008-9/16	9/16"	04008-47/64	47/64"
04008-15/64	15/64"	04008-13/32	13/32"	04008-37/64	37/64"	04008-3/4	3/4"
04008-1/4	1/4"	04008-27/64	27/64"	04008-19/32	19/32"		



Features

- Increases holding power by 75%
- Balanced to 25,000 RPM
- Better rigidity and less T.I.R. (runout)

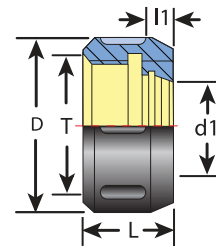

TG75 PowerCOAT Collet Nut

Part No.	Description	D	d1	T	I1	L	Wrench	Torque
84012	TG75 Collet Nut	1.88"	-	1 1/2 - 12"	0.32"	0.94"	04618	90 ft/lb

Precision TG100 Collets and PowerCOAT Nut



Features

- .0004" T.I.R.
- Precision ground & hand inspected
- Clamping range: 1/64"
- Metric sizes in stock



Dimensions

Series	L	A
TG100	2.375"	1.379"

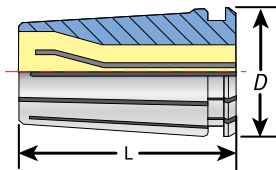

TG100 Sets

Part No.	Pcs.	ID Sizes
04010-59S	59	3/32 - 1" by 64ths
04010-41S	41	3/8 - 1" by 64ths
04010-30S	30	3/32 - 1" by 32nds
04010-21S	21	3/8 - 1" by 32nds
04010-15S	15	1/8 - 1" by 16ths

TG100 Collets

Part No.	Shank	Part No.	Shank	Part No.	Shank	Part No.	Shank
04010-3/32	3/32"	04010-21/64	21/64"	04010-9/16	9/16"	04010-25/32	25/32"
04010-7/64	7/64"	04010-11/32	11/32"	04010-37/64	37/64"	04010-51/64	51/64"
04010-1/8	1/8"	04010-23/64	23/64"	04010-19/32	19/32"	04010-13/16	13/16"
04010-9/64	9/64"	04010-3/8	3/8"	04010-39/64	39/64"	04010-53/64	53/64"
04010-5/32	5/32"	04010-25/64	25/64"	04010-5/8	5/8"	04010-27/32	27/32"
04010-11/64	11/64"	04010-13/32	13/32"	04010-41/64	41/64"	04010-55/64	55/64"
04010-3/16	3/16"	04010-27/64	27/64"	04010-21/32	21/32"	04010-7/8	7/8"
04010-13/64	13/64"	04010-7/16	7/16"	04010-43/64	43/64"	04010-57/64	57/64"
04010-7/32	7/32"	04010-29/64	29/64"	04010-11/16	11/16"	04010-29/32	29/32"
04010-15/64	15/64"	04010-15/32	15/32"	04010-45/64	45/64"	04010-59/64	59/64"
04010-1/4	1/4"	04010-31/64	31/64"	04010-23/32	23/32"	04010-15/16	15/16"
04010-17/64	17/64"	04010-1/2	1/2"	04010-47/64	47/64"	04010-61/64	61/64"
04010-9/32	9/32"	04010-33/64	33/64"	04010-3/4	3/4"	04010-31/32	31/32"
04010-19/64	19/64"	04010-17/32	17/32"	04010-49/64	49/64"	04010-63/64	63/64"
04010-5/16	5/16"	04010-35/64	35/64"	04010-20	20mm	04010-1	1.0"



Features

- Increases holding power by 75%
- Balanced to 25,000 RPM
- Better rigidity and less T.I.R. (runout)

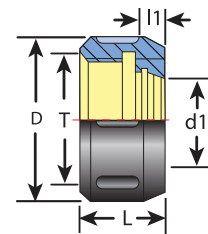

TG100 PowerCOAT Nut

Part No.	Description	D	d1	T	l1	L	Spanner	Torque
28110	TG100 Collet Nut	2.35"	1.12"	1 7/8 - 12"	0.44"	1.18"	03691	90 ft/lb



Precision TG100 Coolant Collets and PowerCOAT Nut



Features

- Up to 750 PSI coolant
- .0004" T.I.R.
- Clamping range: 1/64"



Nuts
pg. 64

Coolant
Rings
pg. 66

Retention
Knobs
pg. 228

Wrenches
pg. 232

Use with TG PowerCOAT Nut

Dimensions

Series	L	A
TG100	2.375"	1.379"

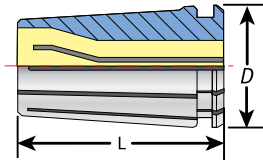

TG100 Coolant Collet Sets



Part No.	Pcs.	ID Sizes
84063-25(SET)	25	1/4" - 1.0" by 64ths
84063-57S	57	1/8" - 1.0" by 64ths

TG100 Coolant Collets

Part No.	Shank Size	Part No.	Shank Size	Part No.	Shank Size	Part No.	Shank Size
84063-3/32	3/32"	84063-9/32	9/32"	84063-1/2	1/2"	84063-3/4	3/4"
84063-7/64	7/64"	84063-19/64	19/64"	84063-33/64	33/64"	84063-49/64	49/64"
84063-1/8	1/8"	84063-5/16	5/16"	84063-17/32	17/32"	84063-25/32	25/32"
84063-9/64	9/64"	84063-21/64	21/64"	84063-9/16	9/16"	84063-51/64	51/64"
84063-5/32	5/32"	84063-11/32	11/32"	84063-19/32	19/32"	84063-13/16	13/16"
84063-11/64	11/64"	84063-23/64	23/64"	84063-39/64	39/64"	84063-53/64	53/64"
84063-3/16	3/16"	84063-3/8	3/8"	84063-5/8	5/8"	84063-27/32	27/32"
84063-13/64	13/64"	84063-13/32	13/32"	84063-41/64	41/64"	84063-55/64	55/64"
84063-7/32	7/32"	84063-27/64	27/64"	84063-21/32	21/32"	84063-7/8	7/8"
84063-15/64	15/64"	84063-7/16	7/16"	84063-43/64	43/64"	84063-57/64	57/64"
84063-1/4	1/4"	84063-29/64	29/64"	84063-11/16	11/16"	84063-29/32	29/32"
84063-17/64	17/64"	84063-15/32	15/32"	84063-23/32	23/32"	84063-59/64	59/64"
		84063-31/64	31/64"	84063-47/64	47/64"	84063-15/16	15/16"
						84063-61/64	61/64"
						84063-31/32	31/32"
						84063-63/64	63/64"
						84063-1	1.0"

Blue indicates coolant.



Features

- Works with TG100 collets
- Up to 1,500 PSI coolant
- Increases holding power by 75%

ER32 coolant ring snaps into the nut to seal the tool shank (page 66).

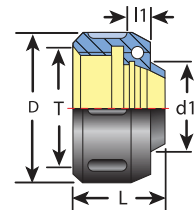

PowerCOAT TG100 Coolant Nut

Part No.	Description	D	d1	T	l1	L	Wrench	Torque
28210	TG100 Coolant Nut	2.35"	0.95"	1 7/8 - 12"	0.44"	1.41"	03691	90 ft/lb

Precision TG150 Collets and Collet Sets



Features

- .0004" T.I.R.
- Precision ground & hand inspected
- Clamping range: 1/64"



Dimensions

Series	L	A
TG150	3.0"	2.001"

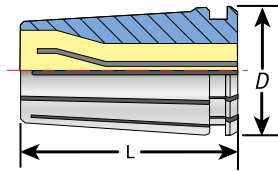

TG150 Sets

Part No.	Pieces	ID Sizes
04011-65S	65	1/2 - 1 1/2" by 64ths
04011-33S	33	1/2 - 1 1/2" by 32nds
04011-17S	17	1/2 - 1 1/2" by 16ths

TG150 Collets

Part No.	Shank	Part No.	Shank	Part No	Shank	Part No	Shank
04011-17/64	17/64"	04011-23/32	23/32"	04011-31/32	31/32"	04011-1 1/4	1-1/4"
04011-3/8	3/8"	04011-47/64	47/64"	04011-63/64	63/64"	04011-1 17/64	1-17/64"
04011-7/32	7/32"	04011-3/4	3/4"	04011-1	1 0"	04011-1 9/32	1-9/32"
04011-1/2	1/2"	04011-49/64	49/64"	04011-1 1/64	1-1/64"	04011-1 19/64	1-19/64"
04011-33/64	33/64"	04011-25/32	25/32"	04011-1 1/32	1-1/32"	04011-1 5/16	1-5/16"
04011-17/32	17/32"	04011-51/64	51/64"	04011-1 3/64	1-3/64"	04011-1 21/64	1-21/64"
04011-35/64	35/64"	04011-13/16	13/16"	04011-1 1/16	1-1/16"	04011-1 11/32	1-11/32"
04011-9/16	9/16"	04011-53/64	53/64"	04011-1 5/64	1-5/64"	04011-1 23/64	1-23/64"
04011-37/64	37/64"	04011-27/32	27/32"	04011-1 3/32	1-3/32"	04011-1 3/8	1-3/8"
04011-19/32	19/32"	04011-55/64	55/64"	04011-1 7/64	1-7/64"	04011-1 25/64	1-25/64"
04011-39/64	39/64"	04011-7/8	7/8"	04011-1 1/8	1-1/8"	04011-1 13/32	1-13/32"
04011-5/8	5/8"	04011-57/64	57/64"	04011-1 9/64	1-9/64"	04011-1 27/64	1-27/64"
04011-41/64	41/64"	04011-29/32	29/32"	04011-1 5/32	1-5/32"	04011-1 7/16	1-7/16"
04011-21/32	21/32"	04011-59/64	59/64"	04011-1 11/64	1-11/64"	04011-1 29/64	1-29/64"
04011-43/64	43/64"	04011-15/16	15/16"	04011-1 3/16	1-3/16"	04011-1 15/32	1-15/32"
04011-11/16	11/16"	04011-61/64	61/64"	04011-1 13/64	1-13/64"	04011-1 31/64	1-31/64"
04011-45/64	45/64"			04011-1 7/32	1-7/32"	04011-1 1/2	1-1/2"
				04011-1 15/64	1-15/64"		

SYOZ / EOC (DIN 6388) Perske Style



Features

- T.I.R. (runout) .0004"
- Collapse range: 1/64"
- Made from high-carbon steel

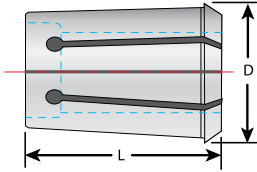

These collets and collet nuts conform to DIN 6388 standards. Snap collet into the nut before screwing the nut onto the spindle or holder.



Retention
Knobs
pg. 206



Wrenches
pg. 232



Tightening
Stands
pg. 234

SYOC / EOC Collet Dimensions

Part No.	L	D
SYOZ 20	34mm	20mm
SYOZ 25	52mm	35mm
EOC 08	26mm	14.4mm
EOC 16	40mm	25.5mm

SYOZ20

Various metric and inch sizes available from stock.

SYOZ25 Collets

Part No.	Shank Size
83868-1/8	1/8"
83868-3/16	3/16"
83868-1/4	1/4"
83868-5/16	5/16"
83868-3/8	3/8"
83868-7/16	7/16"
83868-1/2	1/2"
83868-9/16	9/16"
83868-5/8	5/8"
83868-3/4	3/4"
83868-7/8	7/8"
83868-1	1.0"
83868-10	10mm
83868-16	16mm
83868-20	20mm
83868-25	25mm

EOC8 Collets

Part No.	Shank Size
83508-0.109	0.109"
83508-1/8	1/8"
83508-3/16	3/16"
83508-1/4	1/4"
03508-17/64	17/64"
83508-3/8	3/8"
83508-5/16	5/16"
03508-03	3mm
03508-04	4mm
03508-08	8mm
03508-L	LH nut
83508-NUT	Nut

EOC 12 Collets

Part No.	Shank Size
83512-1/8	1/8"
83512-3/16	3/16"
83512-1/4	1/4"
83512-5/16	5/16"
83512-3/8	3/8"
83512-7/16	7/16"
83512-1/2	1/2"
83512-10	10mm

EOC16 Collets

Part No.	Shank Size
83531-1/8	1/8"
83531-3/16	3/16"
83531-1/4	1/4"
83531-3/8	3/8"
83531-5/16	5/16"
83531-7/16	7/16"
83531-1/2	1/2"
83531-9/16	9/16"
83531-5/8	5/8"
83531-02	2mm
83531-03	3mm
83531-04	4mm
83531-05	5mm
83531-06	6mm
83531-07	7mm
83531-08	8mm
83531-09	9mm
83531-10	10mm
83531-11	11mm
83531-12	12mm
83531-13	13mm
83531-14	14mm
83531-15	15mm
83531-16	16mm
03636-NUT	Nut
03636-WRENCH	Wrench (Hook 40-42)

DIN 6388 Nuts and Wrenches

Part No.	Description	L	D	Wrench
83508-NUT	EOC08 nut	19	30	-
03636-NUT	EOC16 nut	24	43	03636
83634	SYOZ20/EOC 12 nut	20	35	22220
83634-L	SYOZ20/EOC 12 left-hand nut	20	35	22220
83632	SYOZ25 PowerCOAT nut	30	60	03691

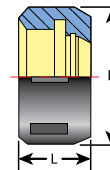

Precision Double Angle (DA) Collets



Features

- Collapse range: 1/64"
- Made from high-carbon steel
- Precision ground accuracy

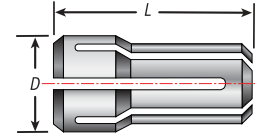

Double Angle Collet Sets*

DA180 Description

01618-9S	9pc 1/4 - 3/4" by 16 ^{ths}
01618-17S	17pc 1/4 - 3/4" by 32 ^{nds}
01618-21S	21pc 1/8 - 3/4" by 32 ^{nds}
01618-33S	33pc 1/4 - 3/4" by 64 ^{ths}
01618-41S	41pc 1/8 - 3/4" by 64 ^{ths}

DA180 Collets	Size
01618-1/16	1/16"
01618-5/64	5/64"
01618-3/32	3/32"
01618-7/64	7/64"
01618-1/8	1/8"
01618-9/64	9/64"
01618-5/32	5/32"
01618-11/64	11/64"
01618-3/16	3/16"
01618-13/64	13/64"
01618-7/32	7/32"
01618-15/64	15/64"
01618-1/4	1/4"
01618-17/64	17/64"
01618-9/32	9/32"
01618-19/64	19/64"
01618-5/16	5/16"
01618-21/64	21/64"
01618-11/32	11/32"
01618-23/64	23/64"
01618-3/8	3/8"
01618-25/64	25/64"
01618-13/32	13/32"
01618-27/64	27/64"
01618-7/16	7/16"
01618-29/64	29/64"
01618-15/32	15/32"
01618-31/64	31/64"
01618-1/2	1/2"
01618-33/64	33/64"

DA100 Description

01610-8S	8pc 1/8 - 9/16" by 16 ^{ths}
01610-15S	15pc 1/8 - 9/16" by 32 ^{nds}
01610-21S	21pc 1/4 - 9/16" by 64 ^{ths}
01610-29S	29pc 1/8 - 9/16" by 64 ^{ths}
01610-33S	33pc 1/16 - 9/16" by 64 ^{ths}

DA100 Collets	Size
01610-17/32	17/32"
01610-35/64	35/64"
01610-9/16	9/16"
01610-37/64	37/64"
01610-19/32	19/32"
01610-39/64	39/64"
01610-5/8	5/8"
01610-41/64	41/64"
01610-21/32	21/32"
01610-43/64	43/64"
01610-11/16	11/16"
01610-45/64	45/64"
01610-23/32	23/32"
01610-47/64	47/64"
01610-3/4	3/4"
DA100 Collets	Size
01610-1/16	1/16"
01610-5/64	5/64"
01610-3/32	3/32"
01610-7/64	7/64"
01610-1/8	1/8"
01610-9/64	9/64"
01610-5/32	5/32"
01610-11/64	11/64"
01610-3/16	3/16"
01610-13/64	13/64"
01610-7/32	7/32"
01610-15/64	15/64"
01610-1/4	1/4"

DA200 Description

01620-9S	9pc 1/8 - 3/8" by 32 ^{nds}
01620-17S	17pc 1/8 - 3/8" by 64 ^{ths}
01620-21S	21pc 1/16 - 3/8" by 64 ^{ths}

DA300 Description

01630-7S	7pc 1/16 - 1/4" by 32 ^{nds}
01630-14S	14pc 3/64 - 1/4" by 64 ^{ths}

DA200 Collets	Size
01620-11/64	11/64"
01620-3/16	3/16"
01620-13/64	13/64"
01620-7/32	7/32"
01620-15/64	15/64"
01620-1/4	1/4"
01620-17/64	17/64"
01620-9/32	9/32"
01620-19/64	19/64"
01620-5/16	5/16"
01620-21/64	21/64"
01620-11/32	11/32"
01620-23/64	23/64"
01620-3/8	3/8"
DA200 Collets	Size
01620-3/64	3/64"
01620-1/16	1/16"
01620-5/64	5/64"
01620-3/32	3/32"
01620-7/64	7/64"
01620-1/8	1/8"
01620-9/64	9/64"
01620-5/32	5/32"

Dimensions

Series	L	D
DA180	1.625"	1.035"
DA100	1.438"	0.769"
DA200	1.188"	0.531"
DA300	1.000"	0.375"

*The last number in the part number indicates the number of collets in the set.

DA300 Collets	Size
01630-3/64	3/64"
01630-1/16	1/16"
01630-5/64	5/64"
01630-3/32	3/32"
01630-7/64	7/64"
01630-1/8	1/8"
01630-9/64	9/64"
01630-5/32	5/32"
01630-11/64	11/64"
01630-3/16	3/16"
01630-13/64	13/64"
01630-7/32	7/32"
01630-15/64	15/64"
01630-1/4	1/4"

CNC Collet Identification and Special Orders Guide

Use the guide below for selecting replacement collets. The best way to tell what type of collet you have is to measure the length of the collet. Collets all have unique measurements. For best results always use a Power-COAT nut tightened to proper specification using an accurate torque wrench.

ER Collet	L	D	Torque Spec
ER8	13mm (.51")	8.5mm (.33")	-
ER11	18mm (.708")	11.5mm (.45")	17 ft/lbs
ER16	27.5mm (1.08")	17mm (.67")	42 ft/lbs
ER20	31.5mm (1.24")	21mm (.83")	59 ft/lbs
ER25	34mm (1.34")	26mm (1.02")	77 ft/lbs
ER32	40mm (1.57")	33mm (1.3")	100 ft/lbs
ER40	46mm (1.81")	41mm (1.61")	130 ft/lbs
ER50	60mm (2.36")	52mm (2.05")	130 ft/lbs

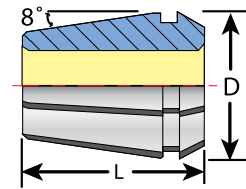

ER Collet Style

TG Collet	L	D	Torque Spec
TG75	47mm (1.85")	27mm (1.06")	90 ft/lbs
TG100	60mm (2.36")	35mm (1.38")	90 ft/lbs
TG150	76mm (3")	51mm (2")	110 ft/lbs

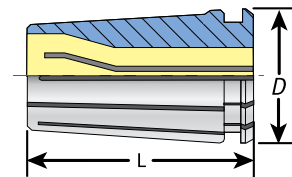

TG Collet Style

SYOZ / EOC Collet	L	D
EOC8	26mm (1.026")	14.4mm (.567")
SYOZ20	34mm (1.34")	20mm (.78")
RDO 20	34mm (1.34")	20mm (.78")
407E	34mm (1.34")	20mm (.78")
EOC 12	34mm (1.34")	20mm (.78")
SYOZ25	52mm (2.06")	35mm (1.38")
RDO 35	52mm (2.06")	35mm (1.38")
462E / SYOZ25	52mm (2.06")	35mm (1.38")
EOC 32	60mm (2.36")	43.7mm (1.72")

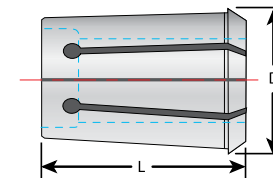

SYOZ Collet Style

DA Collet	L	D
DA180	1.625"	1.035"
DA100	1.438"	.769"
DA200	1.188"	.531"
DA300	1.000"	.375"

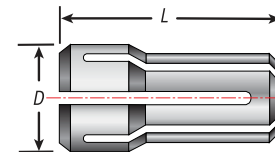

DA Collet Style

DNA Collet	L	D
DNA 11	16.9mm (0.67")	11.5mm (0.45")
DNA 16	24mm (0.94")	17mm (0.67")
DNA 20	30.42mm (1.20")	21.10mm (0.83")
DNA 32	40mm (1.57")	33.25mm (1.31")

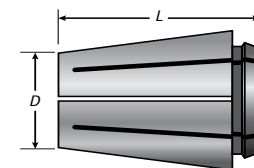

DNA Collet Style

SlimFIT Collet	T	Torque Spec
SBL6	M6 x 1.0P	9 ft/lbs
SBL12	M10 x 1.5P	44 ft/lbs
SBL20	M12 x 1.75P	74 ft/lbs

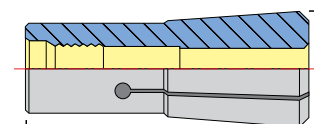

SlimFIT Collet Style

Special Order Collets – Call us for assistance

Length _____ Diameter _____ Other Markings _____

High-Precision End Mill Holders

Extend tool life with our H5 End Mill holders.



Features

- *Balanced to 15,000 RPM at G6.3*
- *DualDRIVE balanced to 25,000 RPM at G2.5*
- *Taper ground to AT3 specification*

Coolant Options

CoolBLAST coolant ports blast coolant on tool path. CoolFLEX holders feature coolant-thru tool or DIN B coolant.

CoolBLAST ports



Manufactured to an H5 Bore Tolerance

All Techniks end mill holder bores are manufactured to meet or exceed the H5 specification. H5 is an extremely accurate bore I.D. and provides improved T.I.R. for extended cutting tool life. (see how T.I.R. affects tool life below)

Brand X = .0008"

Techniks = .0002"

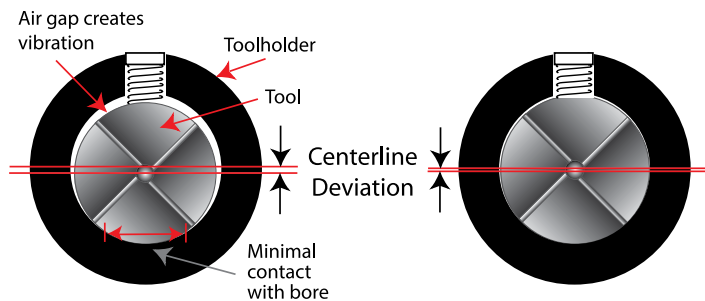

<http://ow.ly/rk7B>
View the video.

You lose 10% of tool life for every .0001" of T.I.R.
Techniks H5 bore tolerance to extends cutting tool life.

Built for Speed.



All Techniks products are backed by our 100% satisfaction guarantee!



We stand behind all our products with our 100% Satisfaction Guarantee • www.techniksusa.com

CAT40 Precision End Mill Holders



Techniks Certified for bore and taper tolerances

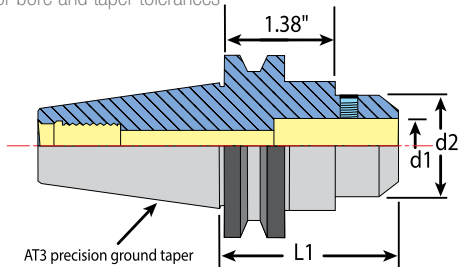

Stubby

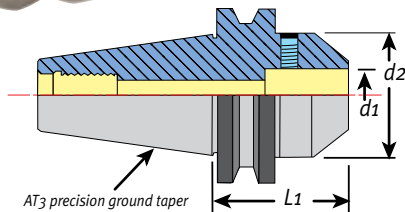

CAT40 Stubby Length End Mill Holders

Part No.	Description	d1	L1	d2
22907-1.75	CAT40 x 1/8" I.D. - 1.75"	1/8"	1.75"	.75"
22909-1.75	CAT40 x 3/16" I.D. - 1.75"	3/16"	1.75"	.79"
22911-1.75	CAT40 x 1/4" I.D. - 1.75"	1/4"	1.75"	.79"
22913-1.75	CAT40 x 5/16" I.D. - 1.75"	5/16"	1.75"	.88"
22915-1.75	CAT40 x 3/8" I.D. - 1.75"	3/8"	1.75"	.88"
22916-1.75	CAT40 x 7/16" I.D. - 1.75"	7/16"	1.75"	1.12"
22917-1.75	CAT40 x 1/2" I.D. - 1.75"	1/2"	1.75"	1.50"
22919-1.75	CAT40 x 5/8" I.D. - 1.75"	5/8"	1.75"	1.50"
22921-1.75	CAT40 x 3/4" I.D. - 1.75"	3/4"	1.75"	1.75"
22925A-1.75	CAT40 x 1.0" I.D. - 1.75"	1.0"	1.75"	2"
22927A-2	CAT40 x 1-1/4" I.D. - 2"	1-1/4"	2"	2.5"

Features

- High precision bore (H5) is best in industry
- Balanced to 15,000 RPM at G6.3
- Taper ground to AT3 for maximum spindle contact

CAT40 End Mill Holders Inch Size

Part No.	Description	d1	L1	d2
22907	CAT40 x 1/8" I.D. - 2.37"	1/8"	2.37"	.69"
22909	CAT40 x 3/16" I.D. - 2.5"	3/16"	2.5"	.69"
22911	CAT40 x 1/4" I.D. - 3"	1/4"	3"	.78"
22911-2.5	CAT40 x 1/4" I.D. - 2.5	1/4"	2.5"	.78"
22913	CAT40 x 5/16" I.D. - 3"	5/16"	3"	.88"
22913-2.5	CAT40 x 5/16" I.D. - 2.5"	5/16"	2.5"	.88"
22915	CAT40 x 3/8" I.D. - 3"	3/8"	3"	1.0"
22915-2.5	CAT40 x 3/8" I.D. - 2.5"	3/8"	2.5"	1.0"
22916-2.5	CAT40 x 7/16" I.D. - 2.5"	7/16"	2.5"	1.13"
22917	CAT40 x 1/2" I.D. - 3"	1/2"	3"	1.25"
22917-2.5	CAT40 x 1/2" I.D. - 2.5"	1/2"	2.5"	1.25"
22917-2.63	CAT40 x 1/2" I.D. - 2.63"	1/2"	2.63"	1.25"
22919	CAT40 x 5/8" I.D. - 3"	5/8"	3"	1.5"
22920	CAT40 x 5/8" I.D. - 3.75"	5/8"	3.75"	1.5"
22921	CAT40 x 3/4" I.D. - 3.5"	3/4"	3.5"	1.75"
22921-3	CAT40 x 3/4" I.D. - 3"	3/4"	3"	1.75"
22923	CAT40 x 7/8" I.D. - 3.5"	7/8"	3.5"	1.88"
22925-3	CAT40 x 1.0" I.D. - 3"	1.0"	3"	2"
22925	CAT40 x 1.0" I.D. - 4"	1.0"	4"	2"
22927	CAT40 x 1.25" I.D. - 4.6"	1.25"	4.6"	2.5"
22927-4	CAT40 x 1.25" I.D. - 4"	1.25"	4"	2.5"
22929	CAT40 x 1.5" I.D. - 4.5"	1.5"	4.5"	2.5"

CAT40 End Mill Holders Metric Size

Part No.	Description	d1	L1	d2
22963	CAT40 x 6mm I.D. - 2.5"	6mm	2.5"	25mm
22965	CAT40 x 8mm I.D. - 2.5"	8mm	2.5"	28mm
22967	CAT40 x 10mm I.D. - 2.5"	10mm	2.5"	35mm
22969	CAT40 x 12mm I.D. - 2.5"	12mm	2.5"	42mm
22971	CAT40 x 16mm I.D. - 2.5"	16mm	2.5"	48mm
22973	CAT40 x 20mm I.D. - 3"	20mm	3"	52mm
22975	CAT40 x 25mm I.D. - 4"	25mm	4"	65mm
22977	CAT40 x 32mm I.D. - 4"	32mm	4"	72mm

CAT40 Precision End Mill Holders



Techniks Certified for bore and taper tolerances

Features

- High precision bore (H5) is best in industry
- Balanced to 15,000 RPM at G6.3
- Taper ground to AT3 for maximum spindle contact

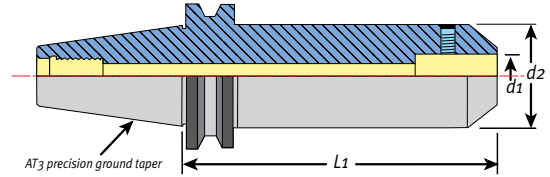

CAT40 Extended Length End Mill Holders

Part No.	Description	d1	L1	d2
22907-6	CAT40 x 1/8" I.D. - 6"	1/8"	6"	.69"
22909-6	CAT40 x 3/16" I.D. - 6"	3/16"	6"	.69"
22911-6	CAT40 x 1/4" I.D. - 6"	1/4"	6"	.78"
22915-5	CAT40 x 3/8" I.D. - 5"	3/8"	5"	1.0"
NEW 22915-6	CAT40 x 3/8" I.D. - 6"	3/8"	6"	1.0"
22917-4.63	CAT40 x 1/2" I.D. - 4.63"	1/2"	4.63"	1.25"
NEW 22917-6	CAT40 x 1/2" I.D. - 6"	1/2"	6"	1.25"
22920-5.75	CAT40 x 5/8" I.D. - 5.75"	5/8"	5.75"	1.5"
22921-5	CAT40 x 3/4" I.D. - 5"	3/4"	5"	1.75"
NEW 22921-6.5	CAT40 x 3/4" I.D. - 6.5"	3/4"	6.5"	1.75"
22925-6	CAT40 x 1.0" I.D. - 6"	1.0"	6"	2"
22927-6	CAT40 x 1 -1/4" I.D. - 6"	1 -1/4"	6"	2.5"



Techniks Certified for bore and taper tolerances

Our Rigid Reach End Mill holders are great for machining in tight areas at extended length where tolerance is important. The tapered design improves rigidity and overall cutting performance.

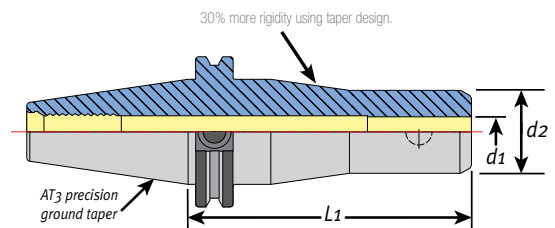

CAT40 Rigid Reach End Mill Holders

Part No.	Description	d1	L1	d2
22907-5.00-RR	CAT40 x 1/8" I.D. - 5"	1/8"	5"	.78"
22909-4.72-RR	CAT40 x 3/16" I.D. - 4.72"	3/16"	4.72"	.78"
22911-4.72-RR	CAT40 x 1/4" I.D. - 4.72"	1/4"	4.72"	.78"
22913-4.72-RR	CAT40 x 5/16" I.D. - 4.72"	5/16"	4.72"	.86"
22915-4.72-RR	CAT40 x 3/8" I.D. - 4.72"	3/8"	4.72"	1.0"
22917-4.72-RR	CAT40 x 1/2" I.D. - 4.72"	1/2"	4.72"	1.38"



CAT40 Precision CoolBLAST End Mill Holders



Features

- High precision bore (H5) is best in industry
- Balanced to 15,000 RPM at G6.3
- Taper ground to AT3 specification



Techniks Certified for bore and taper tolerances



Retention
Knobs
pg. 228



Lock
Screws
pg. 91



Wrenches
pg. 232



Tightening
Stands
pg. 234



CoolBLAST ports



CoolBLAST in-the-bore coolant ports blast coolant on the tool path, even at high RPMs.

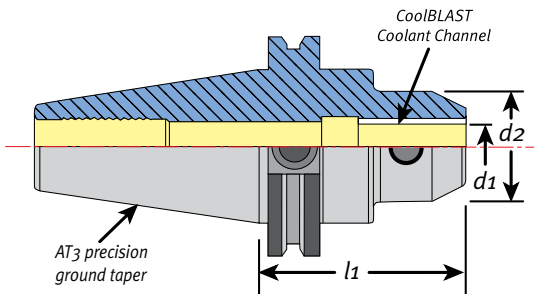

CAT40 CoolBLAST End Mill Holders

Part No.	Description	d1	l1	d2
22909-6B	CAT40 x 3/16" I.D. - 6"	3/16"	6"	.69"
22911-2.5B	CAT40 x 1/4" I.D. - 2.5"	1/4"	2.5"	.78"
22911-6B	CAT40 x 1/4" I.D. - 6"	1/4"	6"	.78"
22915-2.5B	CAT40 x 3/8" I.D. - 2.5"	3/8"	2.5"	1.0"
22915-4B	CAT40 x 3/8" I.D. - 4"	3/8"	4"	1.0"
22917-2.5B	CAT40 x 1/2" I.D. - 2.5"	1/2"	2.5"	1.25"
22917B	CAT40 x 1/2" I.D. - 3"	1/2"	3"	1.25"
22917-4B	CAT40 x 1/2" I.D. - 4"	1/2"	4"	1.25"
22919B	CAT40 x 5/8" I.D. - 3"	5/8"	3"	1.5"
22919-4B	CAT40 x 5/8" I.D. - 4"	5/8"	4"	1.5"
22921-1.75B	CAT40 x 3/4" I.D. - 1.75"	3/4"	1.75"	1.75"
22921-3B	CAT40 x 3/4" I.D. - 3"	3/4"	3"	1.75"
22921-4B	CAT40 x 3/4" I.D. - 4"	3/4"	4"	1.75"
22925B	CAT40 x 1.0" I.D. - 4"	1.0"	4"	2"

Blue indicates coolant.

CAT40 Precision CoolBLAST/CoolFLEX End Mill Holders



Techniks Certified for bore and taper tolerances

Features

- High precision bore (H5) is best in industry
- Balanced to 15,000 RPM at G6.3
- Taper ground to AT3 specification



CoolBLAST in-the-bore coolant ports blast coolant on the tool path, even at high RPMs.

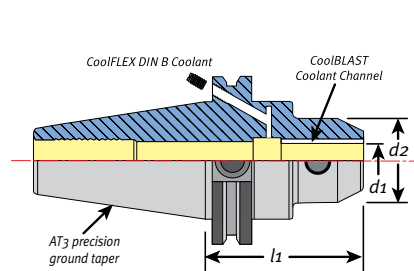

CoolFLEX Feature

CoolFLEX holders are factory set for coolant-thru spindle. Simply remove 2 stop screws for DIN B coolant-thru flange.

Part No.	Description
HSA-4-6	40 taper DIN B screw

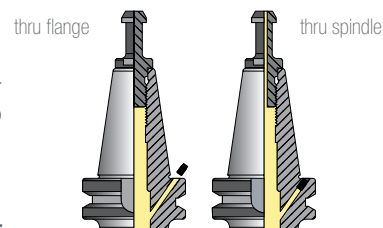

Coolant Set Screws page 47.

CAT40 CoolBLAST Holders with CoolFLEX

Part No.	Description	d1	l1	d2
22909-6FB	CAT40 x 3/16" I.D. - 6"	3/16"	6"	.69"
22911-2.5FB	CAT40 x 1/4" I.D. - 2.5"	1/4"	2.5"	.78"
22911-4FB	CAT40 x 1/4" I.D. - 4"	1/4"	4"	.78"
22911-6FB	CAT40 x 1/4" I.D. - 6"	1/4"	6"	.78"
22913-6FB	CAT40 x 5/16" I.D. - 6"	5/16"	6"	.88"
22915-2.5FB	CAT40 x 3/8" I.D. - 2.5"	3/8"	2.5"	1.0"
22915-5FB	CAT40 x 3/8" I.D. - 5"	3/8"	5"	1.0"
22917-2.5FB	CAT40 x 1/2" I.D. - 2.5"	1/2"	2.5"	1.25"
22917-4FB	CAT40 x 1/2" I.D. - 4"	1/2"	4"	1.25"
22919-1.75FB	CAT40 x 5/8" I.D. - 1.75"	5/8"	1.75"	1.5"
22920-6FB	CAT40 x 5/8" I.D. - 6"	5/8"	6"	1.5"
22921-3FB	CAT40 x 3/4" I.D. - 3"	3/4"	3"	1.75"
22925FB	CAT40 x 1.0" I.D. - 4"	1.0"	4"	2"

Blue indicates coolant.



CAT40 Precision CoolFLEX End Mill Holders



Techniks Certified for bore and taper tolerances

Features

- High precision bore (H5) is best in industry
- Balanced to 15,000 RPM at G6.3
- Taper ground to AT3 specification

CoolFLEX Feature

CoolFLEX holders are factory set for coolant-thru spindle. Simply remove two stop screws for DIN B coolant-thru flange.

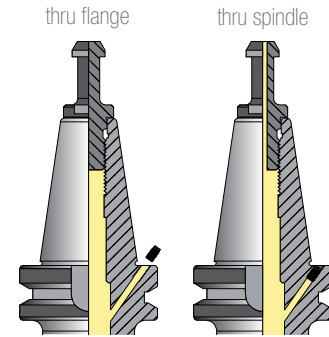

Replacement CoolFLEX Screws

Part No.	Description
HSA-4-6	40 taper DIN B screw

Coolant Set Screws page 47.

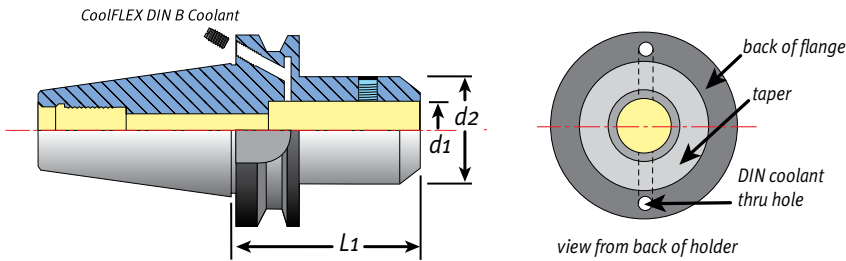

CAT40 CoolFLEX End Mill Holders

Part No.	Description	d1	l1	d2
22911F	CAT40 x 1/4" I.D. - 3"	1/4"	3"	.78"
22911-2.5F	CAT40 x 1/4" I.D. - 2.5"	1/4"	2.5"	.78"
22913-2.5F	CAT40 x 5/16" I.D. - 2.5"	5/16"	2.5"	.88"
22913F	CAT40 x 5/16" I.D. - 3"	5/16"	3"	.88"
22915-2.5F	CAT40 x 3/8" I.D. - 2.5"	3/8"	2.5"	1.0"
22915F	CAT40 x 3/8" I.D. - 3"	3/8"	3"	1.0"
22915-5F	CAT40 x 3/8" I.D. - 5"	3/8"	5"	1.0"
22916-2.5F	CAT40 x 7/16" I.D. - 2.5"	7/16"	2.5"	1.13"
22917F	CAT40 x 1/2" I.D. - 3"	1/2"	3"	1.25"
22919-1.75F	CAT40 x 5/8" I.D. - 1.75"	5/8"	1.75"	1.5"
22919F	CAT40 x 5/8" I.D. - 3"	5/8"	3"	1.5"
22921-1.75F	CAT40 x 3/4" I.D. - 1.75"	3/4"	1.75"	1.75"
22921-3F	CAT40 x 3/4" I.D. - 3"	3/4"	3"	1.75"
22921-5F	CAT40 x 3/4" I.D. - 5"	3/4"	5"	1.75"
22925-1.75F	CAT40 x 1.0" I.D. - 1.75"	1.0"	1.75"	2"
22925F	CAT40 x 1.0" I.D. - 4"	1.0"	4"	2"
22927F	CAT40 x 1-1/4" I.D. - 4.6"	1-1/4"	4.6"	2.5"
22929F	CAT40 x 1-1/2" I.D. - 4.5"	1-1/2"	4.5"	2.5"

Blue indicates coolant.

CAT40 DualDRIVE for Dual-Contact Spindles



Techniks Certified for bore and taper tolerances



Retention
Knobs
pg. 228



Lock
Screws
pg. 91



Wrenches
pg. 232



Tightening
Stands
pg. 234

Features

- High precision bore (H5) is best in industry
- Balanced to 25,000 RPM at G2.5
- Taper ground to AT3 specification

DualDRIVE for Dual Contact spindles

- Techniks Certified for Dual Contact
- Also for use in standard spindles

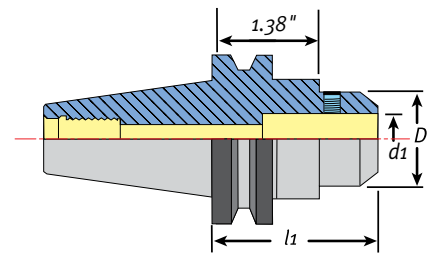

CAT40 DualDRIVE End Mill Holders

Part No.	Description d1 – l1	l1	d1	D
43.653.56.300	CAT40 x SLN 3/8" - 3" DualDRIVE toolholder	3"	3/8"	1"
43.653.56.500	CAT40 x SLN 3/8" - 5" DualDRIVE toolholder	5"	3/8"	1"
43.653.58.300	CAT40 x SLN 1/2" - 3" DualDRIVE toolholder	3"	1/2"	1.25"
43.653.58.463	CAT40 x SLN 1/2" - 4.63" DualDRIVE toolholder	4.63"	1/2"	1.25"
43.653.61.300	CAT40 x SLN 5/8" - 3" DualDRIVE toolholder	3"	5/8"	1.5"
43.653.61.375	CAT40 x SLN 5/8" - 3.75" DualDRIVE toolholder	3.75"	5/8"	1.5"
43.653.61.575	CAT40 x SLN 5/8" - 5.75" DualDRIVE toolholder	5.75"	5/8"	1.5"
43.653.64.350	CAT40 x SLN 3/4" - 3.5" DualDRIVE toolholder	3.5"	3/4"	1.75"
43.653.64.500	CAT40 x SLN 3/4" - 5" DualDRIVE toolholder	5"	3/4"	1.75"
43.653.68.400	CAT40 x SLN 1.0" - 4" DualDRIVE toolholder	4"	1.0"	2"
43.653.68.600	CAT40 x SLN 1.0" - 6" DualDRIVE toolholder	6"	1.0"	2"
43.653.72.460	CAT40 x SLN 1-1/4" - 4.6" DualDRIVE toolholder	4.6"	1-1/4"	2.5"
43.653.72.400	CAT40 x SLN 1-1/4" - 4" DualDRIVE toolholder	4"	1-1/4"	2.5"
43.653.72.600	CAT40 x SLN 1-1/4" - 6" DualDRIVE toolholder	6"	1-1/4"	2.5"
43.653.77.450	CAT40 x SLN 1-1/2" - 4 1/2" DualDRIVE toolholder	4.5"	1-1/2"	2.5"

Dual-Contact Spindles

Use Techniks DualDRIVE holders if your machine has a dual-contact spindle. Dual-Contact is a spindle option offered by some machine tool builders.

Dual-contact means both the toolholder taper and the flange make contact with the spindle. Dual-contact increases rigidity and accuracy during machining.

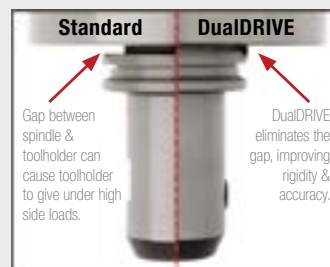

See our demonstration video of DualDRIVE at: <http://ow.ly/sUOqL>



CAT50 Precision End Mill Holders



Techniks Certified for bore and taper tolerances

Features

- High precision bore (H5) is best in industry
- Balanced to 15,000 RPM at G6.3
- Taper ground to AT3 for maximum spindle contact

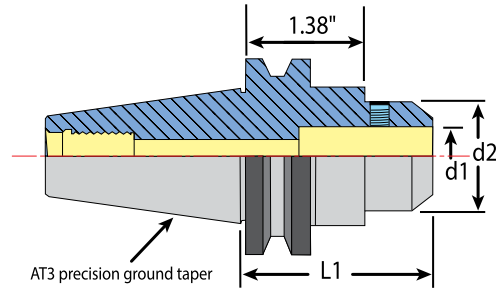

Stubby

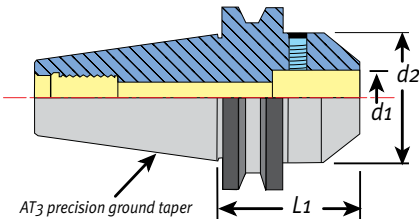

CAT50 End Mill Holders Inch Size

Part No.	Description	d1	L1	d2
22931	CAT50 x 1/4" I.D. - 4"	1/4"	4"	.78"
22933	CAT50 x 5/16" I.D. - 4"	5/16"	4"	.88"
22935	CAT50 x 3/8" I.D. - 4"	3/8"	4"	1.0"
22937	CAT50 x 1/2" I.D. - 4"	1/2"	4"	1.25"
22939-3	CAT50 x 5/8" I.D. - 3"	5/8"	3"	1.5"
22939	CAT50 x 5/8" I.D. - 4"	5/8"	4"	1.5"
22941-3	CAT50 x 3/4" I.D. - 3"	3/4"	3"	1.75"
22941	CAT50 x 3/4" I.D. - 4"	3/4"	4"	1.75"
22943	CAT50 x 7/8" I.D. - 4"	7/8"	4"	1.88"
22945	CAT50 x 1.0" I.D. - 4"	1.0"	4"	2"
22947	CAT50 x 1-1/4" I.D. - 4.6"	1-1/4"	4.6"	2.5"
22949	CAT50 x 1-1/2" I.D. - 4.6"	1-1/2"	4.6"	2.5"

CAT50 Stubby Length End Mill Holders

Part No.	Description	d1	L1	d2
22931-2 1/2	CAT50 x 1/4" I.D. - 2.5"	1/4"	2.5"	.78"
22935-2 1/2	CAT50 x 3/8" I.D. - 2.5"	3/8"	2.5"	1.0"
22937-2 5/8	CAT50 x 1/2" I.D. - 2.67"	1/2"	2.67"	1.5"
22939-9/16-1.44	CAT50 x 9/16" I.D. - 1.44"	9/16"	1.44"	1.5"
22939-9/16-3	CAT50 x 9/16" I.D. - 3"	9/16"	3"	1.5"
22939-1.44	CAT50 x 5/8" I.D. - 1.44"	5/8"	1.44"	1.5"
22941-1.44	CAT50 x 3/4" I.D. - 1.44"	3/4"	1.44"	1.75"
22945-2.62	CAT50 x 1.0" I.D. - 2.62"	1"	2.62"	2"
22947-2.62	CAT50 x 1-1/4" I.D. - 2.62"	1-1/4"	2.62"	2.5"
22949-2	CAT50 x 1-1/2" I.D. - 2"	1-1/2"	2"	2.75"

CAT50 End Mill Holders Metric Size

Part No.	Description	d1	L1	d2
22981	CAT50 x 6mm I.D. - 4"	6mm	4"	25mm
22983	CAT50 x 8mm I.D. - 4"	8mm	4"	28mm
22985	CAT50 x 10mm I.D. - 4"	10mm	4"	35mm
22987	CAT50 x 12mm I.D. - 4"	12mm	4"	42mm
22989	CAT50 x 16mm I.D. - 4"	16mm	4"	48mm
22990	CAT50 x 20mm I.D. - 3"	20mm	3"	52mm
22993	CAT50 x 25mm I.D. - 4"	25mm	4"	65mm
22996	CAT50 x 32mm I.D. - 4.6"	32mm	4.6"	72mm

CAT50 Precision End Mill Holders

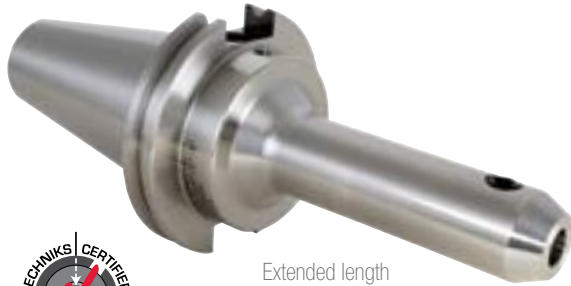

Extended length

Techniks H5 Bore Tolerance Extends Tool Life 60%

Features

- High precision bore (H5) is best in industry
- Balanced to 15,000 RPM at G6.3
- Taper ground to AT3 for maximum spindle contact

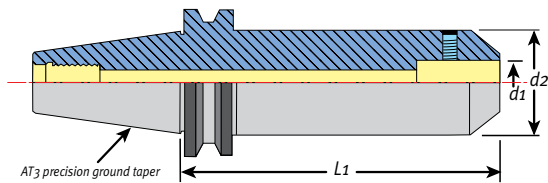

Rigid Reach

30% more rigidity using taper design.

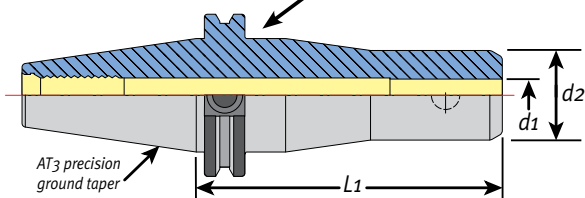

Our Rigid Reach End Mill holders are great for machining in tight areas at extended length where tolerance is important. The tapered design improves rigidity and overall cutting performance.

CAT50 Extended Length End Mill Holders

Part No.	Description	d1	L1	d2	
22931-8	CAT50 x 1/4" I.D. - 8"	1/4"	8"	.78"	NEW
22935-6	CAT50 x 3/8" I.D. - 6"	3/8"	6"	1.0"	
22935-8	CAT50 x 3/8" I.D. - 8"	3/8"	8"	1.0"	
22937-6	CAT50 x 1/2" I.D. - 6"	1/2"	6"	1.25"	
22937-8	CAT50 x 1/2" I.D. - 8"	1/2"	8"	1.25"	
22939-6	CAT50 x 5/8" I.D. - 6"	5/8"	6"	1.5"	
22939-8	CAT50 x 5/8" I.D. - 8"	5/8"	8"	1.5"	
22941-5.75	CAT50 x 3/4" I.D. - 5.75"	3/4"	5.75"	1.75"	
22941-6	CAT50 x 3/4" I.D. - 6"	3/4"	6"	1.75"	
22941-8	CAT50 x 3/4" I.D. - 8"	3/4"	8"	1.75"	
22943-6	CAT50 x 7/8" I.D. - 6"	7/8"	6"	1.88"	
22943-8	CAT50 x 7/8" I.D. - 8"	7/8"	8"	1.88"	
22945-6	CAT50 x 1.0" I.D. - 6"	1.0"	6"	2"	
22946-8	CAT50 x 1.0" I.D. - 8"	1.0"	8"	2"	
22947-6	CAT50 x 1-1/4" I.D. - 6"	1-1/4"	6"	2.5"	
22947-8	CAT50 x 1-1/4" I.D. - 8"	1-1/4"	8"	2.5"	
22951	CAT50 x 2" I.D. - 6"	2"	6"	3.75"	

CAT50 Rigid Reach End Mill Holders

Part No.	Description	d1	L1	d2	
22931-6.5T	CAT50 x 1/4" I.D. - 6.5"	1/4"	6.5"	.78"	
22931-10T	CAT50 x 1/4" I.D. - 10"	1/4"	10"	.78"	NEW
22935-6.5T	CAT50 x 3/8" I.D. - 6.5"	3/8"	6.5"	1.0"	
22935-10T	CAT50 x 3/8" I.D. - 10"	3/8"	10"	1.0"	NEW
22937-6.5T	CAT50 x 1/2" I.D. - 6.5"	1/2"	6.5"	1.38"	
22937-10T	CAT50 x 1/2" I.D. - 10"	1/2"	10"	1.25"	NEW
22939-7.25T	CAT50 x 5/8" I.D. - 7.25"	5/8"	7.25"	1.5"	
22939-10T	CAT50 x 5/8" I.D. - 10"	5/8"	10"	1.5"	NEW
22941-7.25T	CAT50 x 3/4" I.D. - 7.25"	3/4"	7.25"	1.75"	
22941-10T	CAT50 x 3/4" I.D. - 10"	3/4"	10"	1.75"	NEW
22945-8T	CAT50 x 1.0" I.D. - 8"	1.0"	8"	2"	
22945-10T	CAT50 x 1.0" I.D. - 10"	1.0"	10"	2"	NEW
22947-10T	CAT50 x 1-1/4" I.D. - 10"	1-1/4"	10"	2.5"	NEW



CAT50 Precision CoolBLAST End Mill Holders



Techniks Certified for bore and taper tolerances

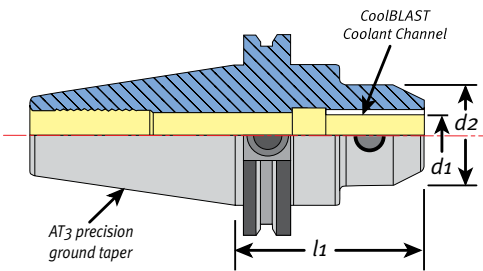

CoolBLAST Features

- Blast coolant directly on tool path
- No need for expensive coolant-thru tools
- High precision bore (H5) is best in industry



Retention Knobs
pg. 228



Lock Screws
pg. 91



Wrenches
pg. 232



Tightening Stands
pg. 234

CoolBLAST ports



CoolBLAST in-the-bore coolant ports blast coolant on the tool path, even at high RPMs.

CAT50 CoolBLAST End Mill Holders

Part No.	Description	d1	l1	d2
22931-2.5B	CAT50 x 1/4" I.D. - 2.5"	1/4"	2.5"	.78"
22931B	CAT50 x 1/4" I.D. - 4"	1/4"	4"	.78"
22931-6B	CAT50 x 1/4" I.D. - 6"	1/4"	6"	.78"
NEW 22931-8B	CAT50 x 1/4" I.D. - 8"	1/4"	8"	.78"
NEW 22931-10BT	CAT50 x 1/4" I.D. - 10"	1/4"	10"	.78"
22935-2.5B	CAT50 x 3/8" I.D. - 2.5"	3/8"	2.5"	1.0"
22935B	CAT50 x 3/8" I.D. - 4"	3/8"	4"	1.0"
22935-6B	CAT50 x 3/8" I.D. - 6"	3/8"	6"	1.0"
22935-8B	CAT50 x 3/8" I.D. - 8"	3/8"	8"	1.0"
NEW 22935-10BT	CAT50 x 3/8" I.D. - 10"	3/8"	10"	1.0"
22937-2.625B	CAT50 x 1/2" I.D. - 2-5/8"	1/2"	2-5/8"	1.25"
22937B	CAT50 x 1/2" I.D. - 4"	1/2"	4"	1.25"
22937-6B	CAT50 x 1/2" I.D. - 6"	1/2"	6"	1.25"
22937-8B	CAT50 x 1/2" I.D. - 8"	1/2"	8"	1.25"
NEW 22937-10BT	CAT50 x 1/2" I.D. - 10"	1/2"	10"	1.25"
22939-3B	CAT50 x 5/8" I.D. - 3"	5/8"	3"	1.5"
22939B	CAT50 x 5/8" I.D. - 4"	5/8"	4"	1.5"
22939-6B	CAT50 x 5/8" I.D. - 6"	5/8"	6"	1.5"
NEW 22939-10BT	CAT50 x 5/8" I.D. - 10"	5/8"	10"	1.5"

Part No.	Description	d1	l1	d2
22941-1.44B	CAT50 x 3/4" I.D. - 1.44"	3/4"	1.44"	1.75"
22941-3B	CAT50 x 3/4" I.D. - 3"	3/4"	3"	1.75"
22941B	CAT50 x 3/4" I.D. - 4"	3/4"	4"	1.75"
22941-6B	CAT50 x 3/4" I.D. - 6"	3/4"	6"	1.75"
22941-8B	CAT50 x 3/4" I.D. - 8"	3/4"	8"	1.75"
22941-10BT	CAT50 x 3/4" I.D. - 10"	3/4"	10"	1.75"
22943-6B	CAT50 x 7/8" I.D. - 6"	7/8"	6"	1.88"
22943-8B	CAT50 x 7/8" I.D. - 8"	7/8"	8"	2"
22945B	CAT50 x 1.0" I.D. - 4"	1.0"	4"	2"
22945-6B	CAT50 x 1.0" I.D. - 6"	1.0"	6"	2"
22946-8B	CAT50 x 1.0" I.D. - 8"	1.0"	8"	2"
22945-10BT	CAT50 x 1.0" I.D. - 10"	1.0"	10"	2"
22947-2.62B	CAT50 x 1-1/4" I.D. - 2.62"	1-1/4"	2.62"	2.5"
22947B	CAT50 x 1-1/4" I.D. - 4.6"	1-1/4"	4.6"	2.5"
22947-6B	CAT50 x 1-1/4" I.D. - 6"	1-1/4"	6"	2.5"
22947-8B	CAT50 x 1-1/4" I.D. - 8"	1-1/4"	8"	2.5"
22947-10BT	CAT50 x 1-1/4" I.D. - 10"	1-1/4"	10"	2.5"
22949B	CAT50 x 1-1/2" I.D. - 4.6"	1-1/2"	4.6"	2.5"
22951B	CAT50 x 2" I.D. - 6"	2"	6"	3.75"

Note: Part numbers with "BT" = Tapered design

CAT50 Precision CoolFLEX End Mill Holders



Techniks Certified for bore and taper tolerances

CoolFLEX Features

- Coolant-thru spindle or thru flange (DIN B)
- High precision bore (H5) is best in industry
- Balanced to 15,000 RPM at G6.3

Techniks H5 Bore Tolerance Extends Tool Life 60%
You lose 10% of cutting tool life
for every .0001" of T.I.R.

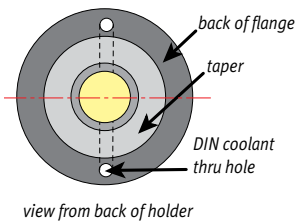
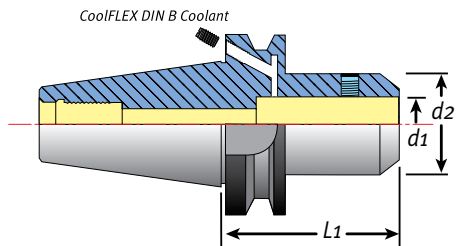
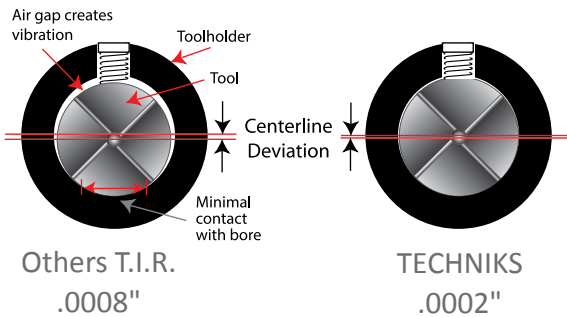

CoolFLEX Feature

CoolFLEX holders are factory set for coolant-thru spindle. Simply remove two stop screws for DIN B coolant-thru flange.

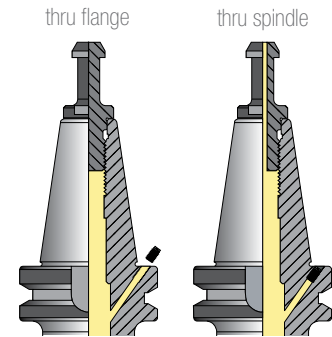

Replacement CoolFLEX Screws

Part No.	Description
HSA-6-6	50 taper DIN B screw

Coolant Set Screws page 47.

CAT50 CoolFLEX End Mill Holders

Part No.	Description	d1	l1	d2
22931F	CAT50 x 1/4" I.D. - 4"	1/4"	4"	.78"
22935F	CAT50 x 3/8" I.D. - 4"	1/4"	4"	1.00"
22937F	CAT50 x 1/2" I.D. - 4"	1/2"	4"	1.25"
22937-6F	CAT50 x 1/2" I.D. - 6"	1/2"	6"	1.25"
22937-8F	CAT50 x 1/2" I.D. - 8"	1/2"	8"	1.25"
22939F	CAT50 x 5/8" I.D. - 4"	5/8"	4"	1.5"
22941-3F	CAT50 x 3/4" I.D. - 3"	3/4"	3"	1.75"
22941F	CAT50 x 3/4" I.D. - 4"	3/4"	4"	1.75"
22945-2.62F	CAT50 x 1" I.D. - 2.62"	1.0"	2.62"	2"
22945F	CAT50 x 1.0" I.D. - 4"	1.0"	4"	2"
22947F	CAT50 x 1-1/4" I.D. - 4.6"	1-1/4"	4.6"	2.5"
22949F	CAT50 x 1-1/2" I.D. - 4.6"	1-1/2"	4.6"	2.5"

Blue indicates coolant.



We stand behind all our products with our 100% Satisfaction Guarantee • www.techniksusa.com

CAT50 DualDRIVE for Dual-Contact Spindles



Techniks Certified for bore and taper tolerances



Retention
Knobs
pg. 228



Lock
Screws
pg. 91



Wrenches
pg. 232



Tightening
Stands
pg. 234

Features

- Techniks Certified for dual-contact spindles
- High precision bore (H5) is best in industry
- Balanced to 25,000 RPM at G2.5

Benefits

- Better rigidity and reduced vibration (chatter)
- Improved performance at high metal removal rates and when machining at extended lengths

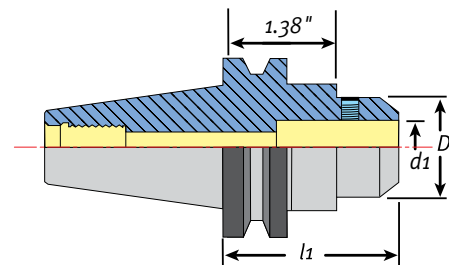

CAT50 DualDRIVE End Mill Holders

Part No.	Description d1 – L1	l1	d1	D
44.653.58.400	CAT50 x SLN 1/2" - 4" DualDRIVE	4"	1/2"	1.25"
44.653.58.600	CAT50 x SLN 1/2" - 6" DualDRIVE	6"	1/2"	1.25"
44.653.61.400	CAT50 x SLN 5/8" - 4" DualDRIVE	4"	5/8"	1.5"
44.653.61.600	CAT50 x SLN 5/8" - 6" DualDRIVE	6"	5/8"	1.5"
44.653.64.144	CAT50 x SLN 3/4" - 1.44" DualDRIVE	1.44"	3/4"	1.75"
44.653.64.300	CAT50 x SLN 3/4" - 3" DualDRIVE	3"	3/4"	1.75"
44.653.64.400	CAT50 x SLN 3/4" - 4" DualDRIVE	4"	3/4"	1.75"
44.653.64.600	CAT50 x SLN 3/4" - 6" DualDRIVE	6"	3/4"	1.75"
44.653.68.400	CAT50 x SLN 1.0" - 4" DualDRIVE	4"	1.0"	2"
44.653.68.262	CAT50 x SLN 1.0" - 2.62" DualDRIVE	2.62"	1.0"	2.484"
44.653.68.600	CAT50 x SLN 1.0" - 6" DualDRIVE	6"	1.0"	2.484"
44.653.72.262	CAT50 x SLN 1-1/4" - 2.62" DualDRIVE	2.62"	1-1/4"	2.75"
44.653.72.460	CAT50 x SLN 1-1/4" - 4.6" DualDRIVE	4.6"	1-1/4"	2.5"
44.653.72.600	CAT50 x SLN 1-1/4" - 6" DualDRIVE	6"	1-1/4"	2.75"
44.653.72.800	CAT50 x SLN 1-1/4" - 8" DualDRIVE	8"	1-1/4"	2.5"
44.653.77.460	CAT50 x SLN 1-1/2" - 4.6" DualDRIVE	4.6"	1-1/2"	2.5"
44.653.77.800	CAT50 x SLN 1-1/2" - 8" DualDRIVE	8"	1-1/2"	2.5"

Dual-Contact Spindles

Use Techniks DualDRIVE holders if your machine has a dual-contact spindle. Dual-Contact is a spindle option offered by some machine tool builders.

Dual-contact means both the toolholder taper and the flange make contact with the spindle. Dual-contact increases rigidity and accuracy during machining.

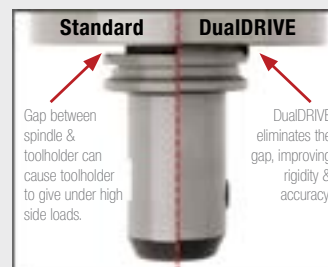

See our demonstration video of DualDRIVE at:
<http://ow.ly/sUOqL>

BT30 and BT30 DualDRIVE for Dual-Contact Spindles



Techniks Certified for bore and taper tolerances

Features

- High precision bore (H5) is best in industry
- Balanced to 15,000 RPM at G6.3
- Taper ground to AT3 for maximum spindle contact

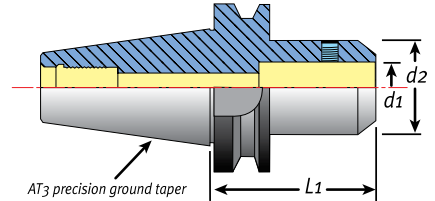

BT30 End Mill Holders

Part No.	Description	d1	L1	d2
17130-1/8	BT30 x 1/8" I.D. - 2.36" End Mill holder	1/8"	2.36"	.68"
17130-3/16	BT30 x 3/16" I.D. - 2.36" End Mill holder	3/16"	2.36"	.68"
17130-1/4	BT30 x 1/4" I.D. - 2.36" End Mill holder	1/4"	2.36"	.78"
17130-5/16	BT30 x 5/16" I.D. - 2.36" End Mill holder	5/16"	2.36"	.88"
17130-3/8	BT30 x 3/8" I.D. - 2.36" End Mill holder	3/8"	2.36"	1.0"
17130-7/16	BT30 x 7/16" I.D. - 2.36" End Mill holder	7/16"	2.36"	1.12"
17130-1/2	BT30 x 1/2" I.D. - 2.36" End Mill holder	1/2"	2.36"	1.25"
17130-5/8	BT30 x 5/8" I.D. - 2.36" End Mill holder	5/8"	2.36"	1.5"
17130-3/4	BT30 x 3/4" I.D. - 2.36" End Mill holder	3/4"	2.36"	1.75"



Techniks Certified for bore and taper tolerances

Features

- New one-piece design for dual-contact spindles
- High precision bore (H5) is best in industry
- Balanced to 25,000 RPM at G2.5

Benefits

- Better rigidity and reduced vibration
- Improved performance at high metal removal rates or extended lengths

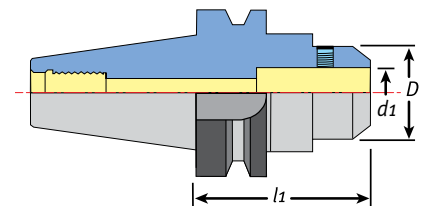

BT30 DualDRIVE End Mill Holders

Part No.	Description d1 – l1	l1	d1	D
25.653.52.250	BT30 x SLN 1/8" - 2.5" DualDRIVE	2.5"	1/8"	.68"
25.653.53.250	BT30 x SLN 3/16" - 2.5" DualDRIVE	2.5"	3/16"	.68"
25.653.54.250	BT30 x SLN 1/4" - 2.5" DualDRIVE	2.5"	1/4"	.78"
25.653.56.250	BT30 x SLN 3/8" - 2.5" DualDRIVE	2.5"	3/8"	1.0"
25.653.58.250	BT30 x SLN 1/2" - 2.5" DualDRIVE	2.5"	1/2"	1.25"
25.653.61.250	BT30 x SLN 5/8" - 2.5" DualDRIVE	2.5"	5/8"	1.5"
25.653.64.300	BT30 x SLN 3/4" - 3" DualDRIVE	3"	3/4"	1.75"



BT40 Precision End Mill Holders



Techniks Certified for bore and taper tolerances

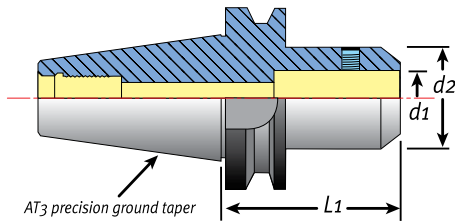

Features

- High precision bore (H5) is best in industry
- Balanced to 15,000 RPM at G6.3
- Taper ground to AT3 for maximum spindle contact

Techniks H5 Bore Tolerance Extends Tool Life 60%
You lose 10% of cutting tool life
for every .0001" of T.I.R.

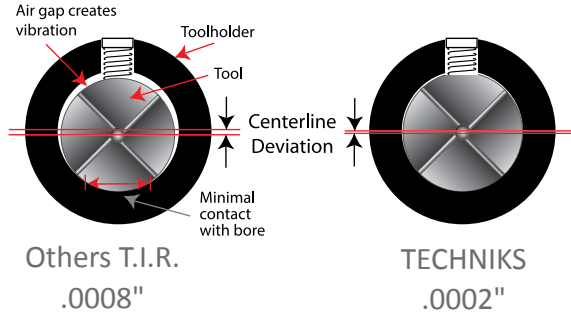

BT40 End Mill Holders Inch Size

Part No.	Description	d1	L1	d2
17140-1/8	BT40 x 1/8" I.D. - 2.5"	1/8"	2.5"	.68"
17140-3/16	BT40 x 3/16" I.D. - 2.5"	3/16"	2.5"	.68"
17140-1/4	BT40 x 1/4" I.D. - 2.5"	1/4"	2.5"	.78"
17140-5/16	BT40 x 5/16" I.D. - 2.5"	5/16"	2.5"	.88"
17140-3/8	BT40 x 3/8" I.D. - 2.5"	3/8"	2.5"	1.0"
17140-7/16	BT40 x 7/16" I.D. - 2.5"	7/16"	2.5"	1.10"
17140-1/2	BT40 x 1/2" I.D. - 2.5"	1/2"	2.5"	1.25"
17140-5/8	BT40 x 5/8" I.D. - 2.5"	5/8"	2.5"	1.50"
17140-3/4	BT40 x 3/4" I.D. - 2.5"	3/4"	2.5"	1.75"
17140-1	BT40 x 1.0" I.D. - 3.56"	1.0"	3.56"	2"
17140-1-1/4	BT40 x 1-1/4" I.D. - 3.56"	1-1/4"	3.56"	2.5"
17140-1-1/2	BT40 x 1-1/2" I.D. - 3.56"	1-1/2"	3.56"	2.5"

BT40 End Mill Holders Metric Size

Part No.	Description	d1	L1	d2
17131	BT40 x 6mm I.D. - 50mm	6mm	50mm	25mm
17132	BT40 x 8mm I.D. - 50mm	8mm	50mm	28mm
17133	BT40 x 10mm I.D. - 63mm	10mm	63mm	35mm
17134	BT40 x 12mm I.D. - 63mm	12mm	63mm	42mm
17135	BT40 x 16mm I.D. - 63mm	16mm	63mm	48mm
17135-18	BT40 x 18mm I.D. - 63mm	18mm	63mm	50mm
17136	BT40 x 20mm I.D. - 63mm	20mm	63mm	52mm
17137	BT40 x 25mm I.D. - 100mm	25mm	100mm	65mm
17138	BT40 x 32mm I.D. - 100mm	32mm	100mm	72mm

BT40 Precision End Mill Holders



Techniks Certified for bore and taper tolerances

Techniks Certified Tooling Features

- High precision bore (H5) is best in industry
- Balanced to 15,000 RPM at G6.3
- Taper ground to AT3 for maximum spindle contact

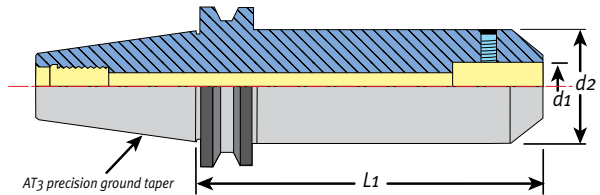

BT40 Extended Length End Mill Holders

Part No.	Description	d1	L1	d2
17140-1/8-4	BT40 x 1/8" I.D. - 4"	1/8"	4"	.68"
17140-3/16-4	BT40 x 3/16" I.D. - 4"	3/16"	4"	.68"
17140-1/4-4	BT40 x 1/4" I.D. - 4"	1/4"	4"	.78"
17140-3/8-4	BT40 x 3/8" I.D. - 4"	3/8"	4"	1.0"
17140-1/2-4	BT40 x 1/2" I.D. - 4"	1/2"	4"	1.25"
17140-5/8-4	BT40 x 5/8" I.D. - 4"	5/8"	4"	1.5"
17140-3/4-4	BT40 x 3/4" I.D. - 4"	3/4"	4"	1.75"
17140-7/8-5	BT40 x 7/8" I.D. - 5"	7/8"	5"	1.75"
17140-1-5	BT40 x 1.0" I.D. - 5"	1.0"	5"	2"



Techniks Certified for bore and taper tolerances

Our Rigid Reach End Mill holders are great for machining in tight areas at extended length where tolerance is important. The tapered design improves rigidity and overall cutting performance.

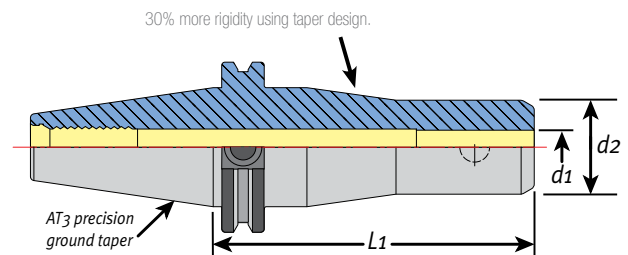

BT40 Rigid Reach End Mill Holders

Part No.	Description	d1	L1	d2
17140-1/8-5.0-RR	BT40 x 1/8" I.D. - 5"	1/8"	5"	.78"
17140-3/16-4.72-RR	BT40 x 3/16" I.D. - 4.72"	3/16"	4.72"	.78"
17140-1/4-4.72-RR	BT40 x 1/4" I.D. - 4.72"	1/4"	4.72"	.78"
17140-3/8-4.72-RR	BT40 x 3/8" I.D. - 4.72"	3/8"	4.72"	1.0"
17140-1/2-4.72-RR	BT40 x 1/2" I.D. - 4.72"	1/2"	4.72"	1.38"
17140-3/4-6-RR	BT40 x 3/4" I.D. - 6"	3/4"	6"	1.38"



BT40 Precision CoolFLEX End Mill Holders



Techniks Certified for bore and taper tolerances

Features

- High precision bore (H5) is best in industry
- Balanced to 15,000 RPM at G6.3
- Taper ground to AT3 specification



Retention
Knobs
pg. 228



Lock
Screws
pg. 91



Wrenches
pg. 232



Tightening
Stands
pg. 234

Techniks H5 Bore Tolerance Extends Tool Life 60%

You lose 10% of cutting tool life
for every .0001" of T.I.R.

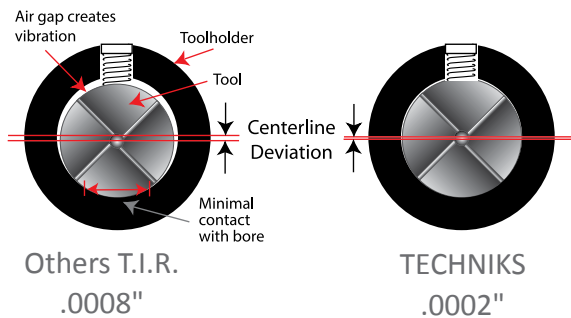

Others T.I.R.
.0008"

TECHNIKS
.0002"

CoolFLEX Feature

CoolFLEX holders are factory set for coolant-thru spindle. Simply remove two stop screws for DIN B coolant-thru flange.

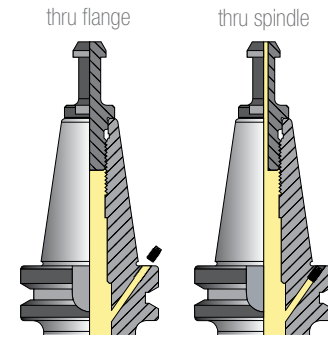

Replacement CoolFLEX Screws

Part No.	Description
HSA-4-6	40 taper DIN B screw

Coolant Set Screws page 47.

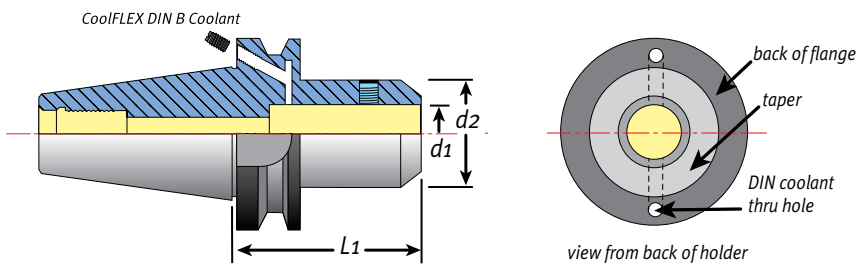

BT40 CoolFLEX End Mill Holders

Part No.	Description	d1	L1	d2
17140-1/4F	BT40 x 1/4" I.D. - 2.5"	1/4"	2.5"	.78"
17140-3/8F	BT40 x 3/8" I.D. - 2.5"	3/8"	2.5"	1.0"
17140-1/2F	BT40 x 1/2" I.D. - 2.5"	1/2"	2.5"	1.25"
17140-5/8F	BT40 x 5/8" I.D. - 2.5"	5/8"	2.5"	1.50"
17140-3/4F	BT40 x 3/4" I.D. - 2.5"	3/4"	2.5"	1.75"
17140-1F	BT40 x 1.0" I.D. - 3.56"	1.0"	3.56"	2"
17140-1-1/4F	BT40 x 1-1/4" I.D. - 3.56"	1-1/4"	3.56"	2.5"

Blue indicates coolant.

BT50 Precision End Mill Holders – End Mill Lock Screws



Techniks Certified for bore and taper tolerances

Features

- High precision bore (H5) is best in industry
- Balanced to 15,000 RPM at G6.3
- Taper ground to AT3 for maximum spindle contact

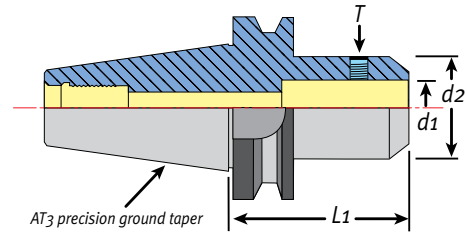

BT50 End Mill Holders

Part No.	Description	d1	l1	d2
17150-1/4	BT50 x 1/4" I.D. - 3"	1/4"	3"	.78"
17150-3/8	BT50 x 3/8" I.D. - 2.75"	3/8"	2.75"	1.0"
17150-1/2	BT50 x 1/2" I.D. - 3"	1/2"	3"	1.25"
17150-5/8	BT50 x 5/8" I.D. - 3"	5/8"	3"	1.5"
17150-3/4	BT50 x 3/4" I.D. - 3"	3/4"	3"	1.75"
17150-1-4.5	BT50 x 1.0" I.D. - 4.5"	1.0"	4.5"	2"
17150-1-6	BT50 x 1.0" I.D. - 6"	1.0"	6"	2"
17150-1-1/4-4.5	BT50 x 1.25" I.D. - 4.5"	1.25"	4.5"	2.5"
18593	BT50 x 1.5" I.D. - 4.13"	1.5"	4.13"	-

Part No.	Fits EMH I.D.	Length	Torque	Stubby Body	Thread
22954-5/16	1/8"	5/16" (.3125)	10 ft/lbs	-	6-32
22955-1/4	3/16"	1/4" (.25)	3 ft/lbs	-	8-32
22956-5/16	1/4"	5/16" (.3125)	5 ft/lbs	-	1/4-28
22957-1/4	3/8"	1/4" (.25)	15 ft/lbs	22915-1.75	5/16-24
22957-5/16	5/16"	5/16" (.3125)	14 ft/lbs	-	5/16-24
22958-5/16	3/8"	5/16" (.3125)	15 ft/lbs	-	3/8-24
22959-5/16	7/16"	5/16" (.3125)	16 ft/lbs	-	7/16-20
22959-3/8	1/2"	3/8" (.375)	20 ft/lbs	-	7/16-20
22959-7/16	5/8"	7/16" (.4375)	40 ft/lbs	-	1/2-20
22961-9/32	1-1/4"	9/32" (.2813)	110 ft/lbs	22927A-2	5/8-18
22961-7/16	1"	7/16" (.4375)	110 ft/lbs	22925-1.75(F) 22923 22925-3	5/8-18
22961-1/2	3/4"	1/2" (.5)	70 ft/lbs	-	5/8-18
22961-1/2	7/8"	1/2" (.5)	70 ft/lbs	-	5/8-18
22962-1/2	1.0"	1/2" (.5)	110 ft/lbs	-	3/4-16
22961-5/8	1-1/4"	5/8" (.625)	110 ft/lbs	22947-2.62	5/8-18

End Mill Holder Replacement Lock Screws

Please specify your bore I.D. (shank size) when ordering replacement lock screws to ensure correct replacement.



Part No.	Metric	Thread
HSA-18-20	18mm	M18 x 2.0P
HSA-20-20	20mm	M20 x 2.0P



HSK63A, 63F, 100A Precision End Mill Holders



HSK63A

Features

- I.D. bore tolerance is H5
- Balanced to 15,000 RPM at G6.3
- Taper ground to AT3 tolerance



Techniks Certified for bore and taper tolerances

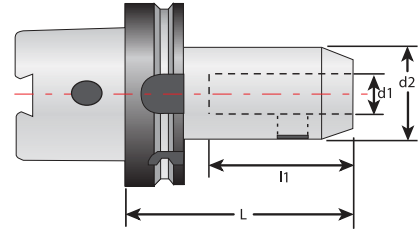

HSK63A End Mill Holders

Part No.	Description - I.D.	d1	d2	L	l1
NEW 32946	HSK63A x End Mill holder 1/8"	1/8"	.68"	3"	.79"
NEW 32946-5	HSK63A x End Mill holder 1/8"	1/8"	.68"	5"	.79"
NEW 32947	HSK63A x End Mill holder 3/16"	3/16"	.68"	3"	1.0"
NEW 32947-5	HSK63A x End Mill holder 3/16"	3/16"	.68"	5"	1.0"
NEW 32948	HSK63A x End Mill holder 1/4"	1/4"	.78"	3"	1.38"
NEW 32948-5	HSK63A x End Mill holder 1/4"	1/4"	.78"	5"	1.38"
NEW 32952	HSK63A x End Mill holder 3/8"	3/8"	1.0"	3"	1.54"
NEW 32952-5	HSK63A x End Mill holder 3/8"	3/8"	1.0"	5"	1.54"
32954	HSK63A x End Mill holder 1/2"	1/2"	1.38"	3"	1.97"
NEW 32954-5	HSK63A x End Mill holder 1/2"	1/2"	1.38"	5"	1.97"
32956	HSK63A x End Mill holder 5/8"	5/8"	1.63"	3.75"	2.09"
NEW 32956-5	HSK63A x End Mill holder 5/8"	5/8"	1.63"	5"	2.09"
32958	HSK63A x End Mill holder 3/4"	3/4"	1.75"	3.75"	2.22"
NEW 32958-6	HSK63A x End Mill holder 3/4"	3/4"	1.75"	6"	2.22"
32962	HSK63A x End Mill holder 1.0"	1.0"	2.00"	3.75"	2.46"
NEW 32964	HSK63A x End Mill holder 1-1/4"	1-1/4"	2.50"	4.25"	2.51"

HSK63F Side Lock End Mill Holders

Part No.	Description - I.D.	d1	d2	L	l1
NEW 32958-4-F	HSK63F x SLN 3/4" - 4.0"	3/4"	1.75"	4.0"	4.0"
NEW 32962-4-F	HSK63F x SLN 1" - 4.0"	1"	2"	4.0"	4.0"
NEW 32838-4-F	HSK63F x SLN 25mm - 4.0"	25mm	65mm	4.0"	4.0"
NEW 32840-4-F	HSK63F x SLN 32mm - 4.0"	32mm	72mm	4.0"	4.0"
NEW 32840-F	HSK63F x SLN 32mm - 110mm	32mm	72mm	110mm	4.0"

HSK100A End Mill Holders

Part No.	Description - I.D.	d1	d2	L	l1
32984	HSK100A x End Mill holder 1/2"	1/2"	1.38"	3.25"	1.97"
32986	HSK100A x End Mill holder 5/8"	5/8"	1.63"	3.75"	2.09"
32988	HSK100A x End Mill holder 3/4"	3/4"	1.75"	3.75"	2.22"
32992	HSK100A x End Mill holder 1"	1"	2.00"	4.25"	2.46"
32994	HSK100A x End Mill holder 1-1/4"	1-1/4"	2.50"	4.25"	2.51"
32996	HSK100A x End Mill holder 1-1/2"	1-1/2"	2.75"	4.50"	2.93"
32998	HSK100A x End Mill holder 2"	2"	3.75"	5.50"	3.53"

Precision ShrinkFIT Holders and Machines

New holder technologies that expand the capabilities of ShrinkFIT tools

NEW Modular ShrinkFIT

- CAT, BT, HSK,
- Balanced 25,000 RPM



SFS ShrinkFIT Modular Adapters

Modular system expands your ShrinkFIT capability without buying additional toolholders.

Tool changes are fast and easy and It is compatible with similar systems.

NEW ShrinkSTATION



(see page 116)

- change tools in only 6-8 seconds
- automatic air cycle
- handles tools up to 22" gauge lengths



TECHNIKS CERTIFIED
ACCURACY BALANCE

We've Expanded our line-up of ShrinkFIT

CAT, BT, HSK, ISO – also more, extended lengths in both inch and metric sizes. Choose Techniks Certified DualDRIVE ShrinkFIT holders for your dual-contact spindles.

NEW 3-Port Coolant-thru Design

Smaller coolant holes for increased pressure & easier tool removal.

CoolBLAST internal coolant paths
CoolFLEX DIN B coolant thru flange

You lose 10% of tool life for every .0001" of T.I.R.
ShrinkFIT T.I.R. of .0001" extends cutting tool life.

Built for Speed.



All Techniks products are backed by our 100% satisfaction guarantee!



We stand behind all our products with our 100% Satisfaction Guarantee • www.techniksusa.com

CAT40 Precision ShrinkFIT Holders – Inch Size



Techniks Certified for accuracy and balance



ShrinkFIT
Machines
pg. 116



ShrinkFIT
Extensions
pg. 115



Retention
Knobs
pg. 228



Wrenches
pg. 232

ShrinkFIT Holder Features

- Maximum T.I.R. only 0.0001"
- Balanced 25,000 RPM at G2.5
- Comes with coolant-thru set screw installed

ShrinkFIT toolholders provide concentric clamping force of 10,000 lbs. or more directly on the cutting tool shank to reduce T.I.R. (runout). This allows operators to run faster and cutters last longer too.

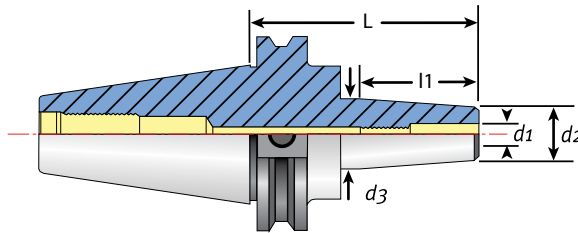

Coolant-thru
set screw included.
Page 115 for dimensions.



CAT40 ShrinkFIT Holders

Part No.	Description	d1	d2	d3	L	l1	thread	coolant screw
29002	CAT40 x 1/8" I.D. - 3.5"	1/8"	.36"	.63"	3.5"	.79"	M6 x 1.0P	16081C-20
29006	CAT40 x 3/16" I.D. - 3.5"	3/16"	.43"	.70"	3.5"	.79"	M6 x 1.0P	16081C-20
29010	CAT40 x 1/4" I.D. - 3"	1/4"	.71"	.94"	3"	1.42"	M5 x 0.8P	16080C-20
29011	CAT40 x 1/4" I.D. - 3.5"	1/4"	.71"	.94"	3.5"	1.42"	M5 x 0.8P	16080C-20
29016	CAT40 x 5/16" I.D. - 3.5"	5/16"	.79"	1.06"	3.5"	1.42"	M6 x 1.0P	16081C-20
29020	CAT40 x 3/8" I.D. - 3"	3/8"	.94"	1.18"	3"	1.53"	M8 x 1.25P	16082C-20
29021	CAT40 x 3/8" I.D. - 3.75"	3/8"	.94"	1.26"	3.75"	1.53"	M8 x 1.25P	16082C-20
29025	CAT40 x 7/16" - 3"	7/16"	.94"	1.18"	3"	1.62"	M10 x 1.5P	16083C-20
29026	CAT40 x 1/2" I.D. - 3"	1/2"	1.10"	1.34"	3"	1.85"	M10 x 1.5P	16083C-20
29027	CAT40 x 1/2" I.D. - 3.75"	1/2"	1.10"	1.34"	3.75"	1.85"	M10 x 1.5P	16083C-20
29032	CAT40 x 5/8" I.D. - 3.75"	5/8"	1.06"	1.34"	3.75"	1.97"	M12 x 1.75P	16085C-20
29034	CAT40 x 3/4" I.D. - 3"	3/4"	1.42"	1.65"	3"	2.04"	M16 x 2.0P	16089C-20
29036	CAT40 x 3/4" I.D. - 4"	3/4"	1.42"	1.65"	4"	2.04"	M16 x 2.0P	16089C-20
29040	CAT40 x 1.0" I.D. - 3"	1.0"	1.81"	2.04"	3"	2.28"	M20 x 2.0P	16091C-20
29042	CAT40 x 1.0" I.D. - 4"	1.0"	1.81"	2.09"	4"	2.28"	M20 x 2.0P	16091C-20
29046	CAT40 x 1-1/4" I.D. - 4"	1-1/4"	1.81"	2.09"	4"	2.28"	M20 x 2.0P	16091C-20

CAT40 Precision Extended Length & SlimLINE



Techniks Certified for accuracy and balance

Features

- Maximum T.I.R. only .0001"
- Balanced 25,000 RPM at G2.5
- Comes with coolant-thru set screw installed

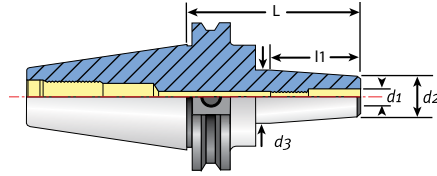

Coolant-thru set screw included. Page 115 for dimensions.



CAT40 Extended Length ShrinkFIT Holders

Part No.	Description	d1	d2	d3	L	l1	thread	coolant screw
29004	CAT40 x 1/8" I.D. - 5"	1/8"	.36"	.87"	5"	.79"	-	16081C-20
29008	CAT40 x 3/16" I.D. - 5"	3/16"	.43"	.71"	5"	.79"	M6 x 1.0P	16081C-20
29013	CAT40 x 1/4" I.D. - 5"	1/4"	.71"	1.06"	5"	1.42"	M5 x 0.8P	16080C-20
29014	CAT40 x 1/4" I.D. - 6"	1/4"	.71"	1.37"	6"	1.42"	M5 x 0.8P	16080C-20
29018	CAT40 x 5/16" I.D. - 5"	5/16"	.79"	1.06"	5"	1.42"	M6 x 1.0P	16081C-20
29023	CAT40 x 3/8" I.D. - 5"	3/8"	.94"	1.37"	5"	1.53"	M8 x 1.25P	16082C-20
29024	CAT40 x 3/8" I.D. - 6"	3/8"	.94"	1.37"	6"	1.53"	M8 x 1.25P	16082C-20
29029	CAT40 x 1/2" I.D. - 5"	1/2"	1.10"	1.37"	5"	1.85"	M10 x 1.5P	16083C-20
29030	CAT40 x 1/2" I.D. - 6"	1/2"	1.10"	1.37"	6"	1.85"	M10 x 1.5P	16083C-20
29037	CAT40 x 3/4" I.D. - 5"	3/4"	1.26"	1.37"	5"	2.04"	M16 x 2.0P	16089C-20
29038	CAT40 x 3/4" I.D. - 6"	3/4"	1.26"	1.37"	6"	2.04"	M16 x 2.0P	16089C-20
29044	CAT40 x 1.0" I.D. - 6"	1.0"	1.81"	2.09"	6"	2.28"	M20 x 2.0P	16091C-20



Features

- Smaller nose diameter (d2)
- Maximum T.I.R. only 0.0001"
- Balanced 25,000 RPM at G2.5

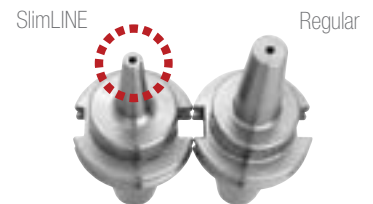

Use SlimLINE holders for finish passes where small nose diameter (d2) tooling is needed.

CAT40 SlimLINE ShrinkFIT Holders Inch Sizes

Part No.	Description	d1	d2	d3	L	l1	thread	coolant screw
31528	CAT40 x 1/8" I.D. - 3.15" SlimLINE	1/8"	.35"	.60"	3.15"	.78"	M6 x 1.0P	16081C-20
31538	CAT40 x 3/16" I.D. - 3.15" SlimLINE	3/16"	.43"	.68"	3.15"	.78"	M6 x 1.0P	16081C-20
31548	CAT40 x 1/4" I.D. - 3.15" SlimLINE	1/4"	.47"	.72"	3.15"	1.42"	M5 x 0.8P	16080C-20
31568	CAT40 x 3/8" I.D. - 3.15" SlimLINE	3/8"	.63"	.88"	3.15"	1.93"	M8 x 1.25P	16082C-20
31588	CAT40 x 1/2" I.D. - 3.15" SlimLINE	1/2"	.70"	.96"	3.15"	1.93"	M10 x 1.5P	16083C-20

CAT40 SlimLINE ShrinkFIT Holders Metric Sizes

Part No.	Description	d1	d2	d3	L	l1	thread	coolant screw
29103	CAT40 x 3mm I.D. - 80mm SlimLINE	3mm	9mm	15.5mm	80mm	45mm	M6 x 1.0P	16081C-20
29104	CAT40 x 4mm I.D. - 80mm SlimLINE	4mm	10mm	16.3mm	80mm	45mm	M6 x 1.0P	16081C-20
29106	CAT40 x 6mm I.D. - 80mm SlimLINE	6mm	12mm	18.3mm	80mm	45mm	M5 x 0.8P	16080C-20



CAT40 Precision ShrinkFIT Toolholders – Metric Size



Techniks Certified for accuracy and balance

ShrinkFIT Features

- Maximum T.I.R. only 0.0001"
- Balanced 25,000 RPM at G2.5
- Comes with coolant-thru set screw installed

ShrinkFIT toolholders provide concentric clamping force of 10,000 lbs. or more directly on the cutting tool shank to reduce T.I.R. (runout). This allows operators to run faster and cutters last longer too.



ShrinkFIT
Machines
pg. 116



ShrinkFIT
Extensions
pg. 115



Retention
Knobs
pg. 228



Wrenches
pg. 232

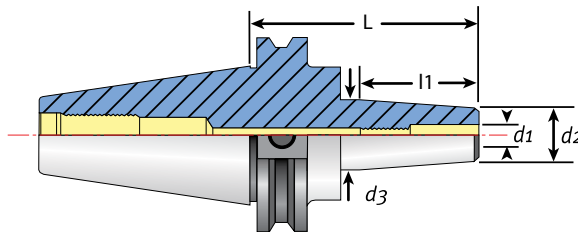

Coolant-thru
set screw included.
Page 115 for dimensions.



CAT40 Metric ShrinkFIT Holders

Part No.	Description	d1	d2	d3	L	l1	thread	coolant screw
29204	CAT40 x 4mm I.D. - 100mm	4mm	10mm	18.7mm	100mm	20mm	M6 x 1.0P	16081C-20
29206	CAT40 x 5mm I.D. - 100mm	5mm	16mm	22mm	100mm	20mm	M8 x 1.25P	16081C-20
29208	CAT40 x 6mm I.D. - 100mm	6mm	21mm	27mm	100mm	36mm	M5 x 0.8P	16080C-20
29210	CAT40 x 6mm I.D. - 150mm	6mm	21mm	27mm	150mm	36mm	M5 x 0.8P	16080C-20
29212	CAT40 x 8mm I.D. - 100mm	8mm	21mm	27mm	100mm	36mm	M6 x 1.0P	16081C-20
29214	CAT40 x 8mm I.D. - 150mm	8mm	21mm	27mm	150mm	36mm	M6 x 1.0P	16081C-20
29216	CAT40 x 10mm I.D. - 100mm	10mm	24mm	32mm	100mm	42mm	M8 x 1.25P	16082C-20
29218	CAT40 x 10mm I.D. - 150mm	10mm	24mm	32mm	150mm	42mm	M8 x 1.25P	16082C-20
29220	CAT40 x 12mm I.D. - 100mm	12mm	24mm	32mm	100mm	47mm	M10 x 1.5P	16083C-20
29222	CAT40 x 12mm I.D. - 150mm	12mm	24mm	32mm	150mm	47mm	M10 x 1.5P	16083C-20
29226	CAT40 x 14mm I.D. - 100mm	14mm	27mm	34mm	100mm	47mm	M10 x 1.5P	16083C-20
29228	CAT40 x 14mm I.D. - 152.4mm	14mm	27mm	34mm	152.4mm	47mm	M10 x 1.5P	16083C-20
29232	CAT40 x 16mm I.D. - 100mm	16mm	27mm	34mm	100mm	50mm	M12 x 1.75P	16085C-20
29234	CAT40 x 16mm I.D. - 160mm	16mm	27mm	34mm	160mm	50mm	M12 x 1.75P	16085C-20
29236	CAT40 x 18mm I.D. - 100mm	18mm	33mm	42mm	100mm	50mm	M12 x 1.75P	16089C-20
29238	CAT40 x 20mm I.D. - 80mm	20mm	33mm	42mm	80mm	52mm	M16 x 2.0P	16089C-20
29240	CAT40 x 25mm I.D. - 101.6mm	25mm	44mm	53mm	101.6mm	58mm	M20 x 2.0P	16091C-20

CAT40 CoolBLAST, CAT40 CoolFLEX Holders



CoolBLAST Features

- Maximum chip removal for maximum feed rates
- Balanced 25,000 RPM at G2.5
- Comes with coolant-thru set screw installed



3-port design features smaller coolant holes for increased pressure & easier tool removal.

CoolBLAST features a 3° angle to better direct coolant on the cutting tool.
CoolBLAST coolant ports direct coolant on the tool path, even at high RPMs.

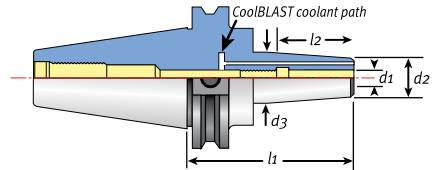

CAT40 CoolBLAST ShrinkFIT Holders

Part No.	Description	d1	d2	d3	L	l1	thread	coolant screw
29004B	CAT40 x 1/8" - 5" with CoolBlast	1/8"	.63"	.87"	5"	.79"	M8 x 1.25P	16081C-20
29008B	CAT40 x 3/16" - 5" with CoolBlast	3/16"	.63"	.87"	5"	.79"	M6 x 1.0P	16081C-20
29014B	CAT40 x 1/4" - 6" with CoolBlast	1/4"	.71"	1.40"	6"	1.42"	M5 x 0.8P	16080C-20
29018B	CAT40 x 5/16" - 5" with CoolBlast	5/16"	.78"	1.06"	5"	1.42"	M6 x 1.0P	16081C-20
29023B	CAT40 x 3/8" I.D. - 5" with CoolBLAST	3/8"	.94"	1.26"	5"	1.53"	M8 x 1.25P	16082C-20
29029B	CAT40 x 1/2" I.D. - 5" with CoolBLAST	1/2"	1.10"	1.34"	5"	1.85"	M10 x 1.5P	16083C-20
29033B	CAT40 x 5/8" I.D. - 5" with CoolBLAST	5/8"	1.06"	1.34"	5"	1.97"	M12 x 1.75P	16085C-20
29036B	CAT40 x 3/4" I.D. - 4" with CoolBLAST	3/4"	1.42"	1.65"	4"	2.04"	M16 x 2.0P	16089C-20
29037B	CAT40 x 3/4" I.D. - 5" with CoolBLAST	3/4"	1.42"	1.65"	5"	2.04"	M16 x 2.0P	16089C-20

Blue indicates coolant.

CoolFLEX Feature

CoolFLEX holders are factory set for coolant-thru spindle. Simply remove 2 stop screws for DIN B coolant-thru flange.

Part No.	Description
HSA-4-6	40 taper DIN B screw

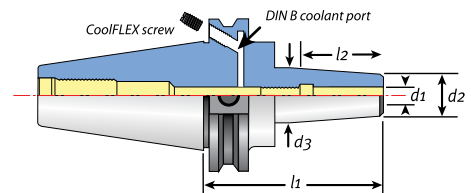
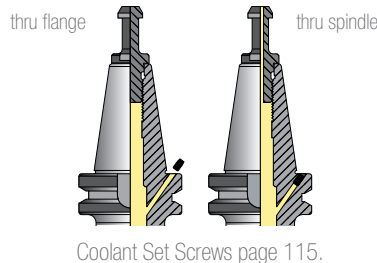

CAT40 CoolFLEX ShrinkFIT Holders

Part No.	Description	d1	d2	d3	L	l1	thread	coolant screw
29011F	CAT40 x 1/4" I.D. - 3.5" with CoolFLEX	1/4"	.71"	1.06"	3.5"	1.42"	M5 x 0.8P	16080C-20
29021F	CAT40 x 3/8" I.D. - 3.75" with CoolFLEX	3/8"	.94"	1.26"	3.75"	1.53"	M8 x 1.25P	16082C-20
29027F	CAT40 x 1/2" I.D. - 3.75" with CoolFLEX	1/2"	1.10"	1.34"	3.75"	1.85"	M10 x 1.5P	16083C-20
29040F	CAT40 x 1.0" I.D. - 3" with CoolFLEX	1.0"	1.81"	2.04"	3"	2.28"	M20 x 2.0P	16091C-20
29042F	CAT40 x 1.0" I.D. - 4" with CoolFLEX	1.0"	1.81"	2.09"	4"	2.28"	M20 x 2.0P	16091C-20
29046F	CAT40 x 1-1/4" I.D. - 4" with CoolFLEX	1-1/4"	1.81"	2.09"	4"	2.28"	M20 x 2.0P	16091C-20

Blue indicates coolant.



CAT40 Precision CoolBLAST/CoolFLEX Holders



Features

- Get CoolBLAST performance from DIN B spindles
- Balanced 25,000 RPM at G2.5
- Comes with coolant-thru set screw installed

CoolBLAST features a 3° angle to better direct coolant on the cutting tool.

CoolBLAST coolant ports direct coolant on the tool path, even at high RPMs.



Techniks Certified for accuracy and balance



ShrinkFIT
Machines
pg. 116



ShrinkFIT
Extensions
pg. 115



Retention
Knobs
pg. 228



Wrenches
pg. 232



3-port design features smaller coolant holes for increased pressure & easier tool removal.



CoolFLEX Feature

CoolFLEX holders are factory set for coolant-thru spindle. Simply remove 2 stop screws for DIN B coolant-thru flange.

Part No.	Description
HSA-4-6	40 taper DIN B screw

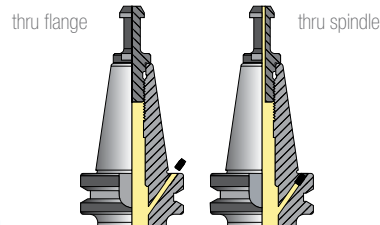

Coolant Set Screws page 115.

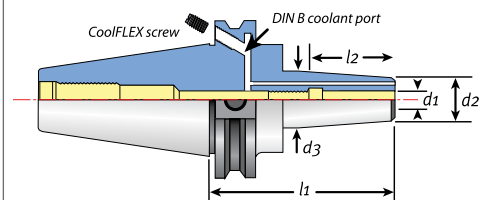

CAT40 CoolBLAST and CoolFLEX DIN B Coolant Capability

Part No.	Description	d1	d2	d3	L	l1	thread	coolant screw
29002FB	CAT40 x 1/8" I.D. - 3.5"	1/8"	.63"	.87"	3.5"	-	M6 x 1.0P	16081C-20
29006FB	CAT40 x 3/16" I.D. - 3.5"	3/16"	.63"	.87"	3.5"	-	M8 x 1.25P	16081C-20
29011FB	CAT40 x 1/4" I.D. - 3.5"	1/4"	.71"	1.06"	3.5"	1.42"	M5 x 0.8P	16080C-20
29016FB	CAT40 x 5/16" I.D. - 3.5"	5/16"	.78"	1.06"	3.5"	1.42"	M6 x 1.0P	16081C-20
29021FB	CAT40 x 3/8" I.D. - 3.75"	3/8"	.94"	1.26"	3.75"	1.53"	M8 x 1.25P	16082C-20
29023FB	CAT40 x 3/8" I.D. - 5"	3/8"	.94"	1.26"	5"	1.53"	M8 x 1.25P	16082C-20
29027FB	CAT40 x 1/2" I.D. - 3.75"	1/2"	1.10"	1.34"	3.75"	1.85"	M10 x 1.5P	16083C-20
29032FB	CAT40 x 5/8" I.D. - 3.75"	5/8"	1.06"	1.34"	3.75"	1.97"	M12 x 1.75P	16085C-20
29036FB	CAT40 x 3/4" I.D. - 4"	3/4"	1.42"	1.65"	4"	2.04"	M16 x 2.0P	16089C-20
29042FB	CAT40 x 1.0" I.D. - 4"	1.0"	1.81"	2.09"	4"	2.28"	M20 x 2.0P	16091C-20

Blue indicates coolant.

CAT40 DualDRIVE for Dual-Contact Spindles



Techniks Certified for accuracy and balance

CoolBLAST features a 3° angle to better direct coolant on the cutting tool.

CoolBLAST coolant ports direct coolant on the tool path, even at high RPMs.

Features

- CoolBLAST ports directs coolant right on tool
- CoolFLEX DIN B coolant-thru spindle or thru flange is standard
- Balanced to 25,000 RPM at G2.5

Benefits

- Better rigidity and reduced vibration (chatter)
- Improved performance at high metal removal rates and when machining at extended lengths



3-port design features smaller coolant holes for increased pressure & easier tool removal.

CoolFLEX Feature

CoolFLEX holders are factory set for coolant-thru spindle. Simply remove 2 stop screws for DIN B coolant-thru flange.

Part No.	Description
HSA-4-6	40 taper DIN B screw

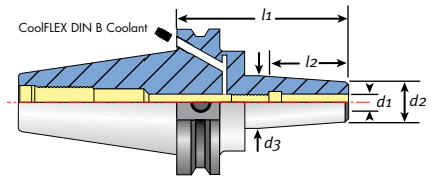
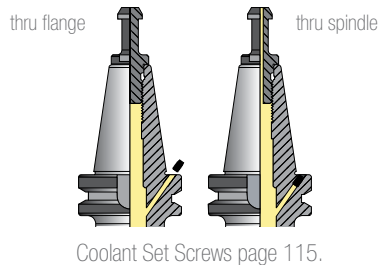

CAT40 DualDRIVE CoolBLAST with DIN B CoolFLEX Holders

Part No.	Description	d1	d2	d3	L	l1	thread	coolant screw
46.651B.58.315	CAT40 x 1/2" - 3.15" DualDRIVE w/BLAST	1/2"	28mm	34mm	3.15"	47mm	M10 x 1.5P	16083C-20
46.651B.64.400	CAT40 x 3/4" - 4" DualDRIVE w/BLAST	3/4"	36mm	42mm	4"	52mm	M16 x 2.0P	16089C-20

Blue indicates coolant.

CAT40 DualDRIVE CoolFLEX (DIN B) ShrinkFIT Holders

Part No.	Description	d1	d2	d3	L	l1	thread	coolant screw
46.651.54.350	CAT40 x 1/4" - 3.5" DualDRIVE w/FLEX	1/4"	18mm	27mm	3.5"	36mm	M5 x 0.8P	16080C-20
46.651.56.375	CAT40 x 3/8" - 3.75" DualDRIVE w/FLEX	3/8"	24mm	32mm	3.75"	42mm	M8 x 1.25P	16082C-20
46.651.58.375	CAT40 x 1/2" - 3.75" DualDRIVE w/FLEX	1/2"	28mm	34mm	3.75"	47mm	M10 x 1.5P	16083C-20
46.651.64.400	CAT40 x 3/4" - 4" DualDRIVE w/FLEX	3/4"	36mm	42mm	4"	52mm	M16 x 2.0P	16089C-20
46.651.68.400	CAT40 x 1.0" - 4" DualDRIVE w/FLEX	1.0"	46mm	53mm	4"	58mm	M20 x 2.0P	16091C-20
46.651.72.400	CAT40 x 1-1/4" DualDRIVE w/FLEX	1-1/4"	46mm	53mm	4"	58mm	M20 x 2.0P	16091C-20

Blue indicates coolant.

Dual-Contact Spindles

Use Techniks DualDRIVE holders if your machine has a dual-contact spindle. Dual-Contact is a spindle option offered by some machine tool builders.

Dual-contact means both the toolholder taper and the flange make contact with the spindle. Dual-contact increases rigidity and accuracy during machining.

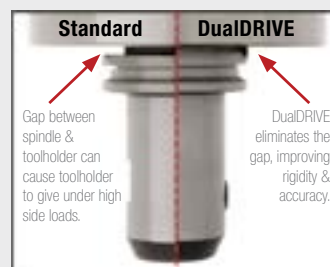

See our demonstration video of DualDRIVE at: <http://ow.ly/sUOqL>



CAT50 Precision ShrinkFIT Toolholders – Inch Size



Techniks Certified for accuracy and balance

Features

- Maximum T.I.R. only 0.0001"
- Balanced 25,000 RPM at G2.5
- Comes with coolant-thru set screw installed



ShrinkFIT
Machines
pg. 116



ShrinkFIT
Extensions
pg. 115



Retention
Knobs
pg. 228



Wrenches
pg. 232

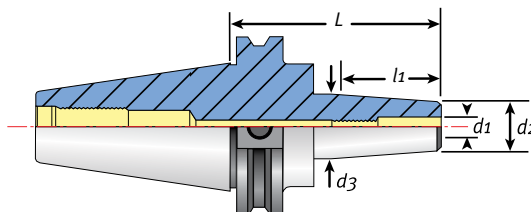

Coolant-thru
set screw included.
Page 115 for dimensions.



CAT50 ShrinkFIT Holders

Part No.	Description	d1	d2	d3	L	l1	thread	coolant screw
29051	CAT50 x 1/8" I.D. - 4"	1/8"	.36"	.72"	4"	.79"	M6 x 1.0P	16081C-20
29052	CAT50 x 3/16" I.D. - 3.54"	3/16"	.42"	.74"	3.54"	.79"	M6 x 1.0P	16081C-20
29054	CAT50 x 1/4" I.D. - 3.54"	1/4"	.71"	1.02"	3.54"	1.42"	M5 x 0.8P	16080C-20
29056	CAT50 x 5/16" I.D. - 3.54"	5/16"	.79"	1.06"	3.54"	1.42"	M6 x 1.0P	16081C-20
29058	CAT50 x 3/8" I.D. - 3.94"	3/8"	.94"	1.26"	3.94"	1.42"	M8 x 1.25P	16082C-20
29060	CAT50 x 1/2" I.D. - 3.94"	1/2"	1.10"	1.34"	3.94"	1.85"	M10 x 1.5P	16083C-20
29062	CAT50 x 5/8" I.D. - 3.94"	5/8"	1.06"	1.34"	3.94"	1.97"	M12 x 1.75P	16085C-20
29064	CAT50 x 3/4" I.D. - 4.13"	3/4"	1.42"	1.65"	4.13"	2.04"	M16 x 2.0P	16089C-20
29068	CAT50 x 1.0" I.D. - 4.13"	1"	1.81"	2.09"	4.13"	2.28"	M20 x 2.0P	16091C-20
29072	CAT50 x 1-1/4" I.D. - 4.13"	1-1/4"	1.81"	2.09"	4.13"	2.28"	M20 x 2.0P	16091C-20
29074	CAT50 x 1-1/4" I.D. - 4.72"	1-1/4"	1.81"	2.09"	4.72"	2.28"	M20 x 2.0P	16091C-20

CAT50 Extended Length ShrinkFIT Holders

Part No.	Description	d1	d2	d3	L	l1	thread	coolant screw
29052-6	CAT50 x 3/16" I.D. - 6"	3/16"	.42"	.71"	6"	.79"	M6 x 1.0P	16081C-20
29054-6	CAT50 x 1/4" I.D. - 6"	1/4"	.71"	1.06"	6"	1.42"	M8 x 1.25P	16080C-20
29054-8	CAT50 x 1/4" I.D. - 8"	1/4"	.71"	1.06"	8"	1.42"	M5 x 0.8P	16080C-20
29058-6	CAT50 x 3/8" I.D. - 6"	3/8"	.78"	1.06"	6"	1.42"	M8 x 1.25P	16082C-20
29058-8	CAT50 x 3/8" I.D. - 8"	3/8"	.78"	1.06"	8"	1.42"	M8 x 1.25P	16082C-20
29060-6	CAT50 x 1/2" I.D. - 6"	1/2"	1.10"	1.34"	6"	1.85"	M10 x 1.5P	16081C-20
29060-8	CAT50 x 1/2" I.D. - 8"	1/2"	1.10"	1.34"	8"	1.85"	M10 x 1.5P	16083C-20
29062-6	CAT50 x 5/8" I.D. - 6"	5/8"	1.06"	1.34"	6"	1.97"	M12 x 1.75P	16085C-20
29066	CAT50 x 3/4" I.D. - 6"	3/4"	1.42"	1.65"	6"	2.04"	M16 x 2.0P	16089C-20
29070	CAT50 x 1.0" I.D. - 6"	1"	1.81"	2.09"	6"	2.28"	M20 x 2.0P	16091C-20
29076	CAT50 x 1-1/4" I.D. - 6"	1-1/4"	1.81"	2.09"	6"	2.28"	M20 x 2.0P	16091C-20

CAT50 Precision ShrinkFIT Toolholders – Metric Size



Techniks Certified for accuracy and balance

Features

- Maximum T.I.R. only 0.0001"
- Balanced 25,000 RPM at G2.5
- Comes with coolant-thru set screw installed



ShrinkFIT
Machines
pg. 116



ShrinkFIT
Extensions
pg. 115



Retention
Knobs
pg. 228



Wrenches
pg. 232

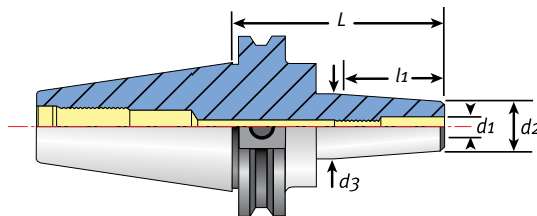

Coolant-thru
set screw included.
Page 115 for dimensions.



CAT50 Metric ShrinkFIT Holders

Part No.	Description	d1	d2	d3	L	l1	thread	coolant screw
29252	CAT50 x 6mm I.D.-100mm	6mm	21mm	27mm	100mm	36mm	M5 x 0.8P	16080C-20
29256	CAT50 x 8mm I.D.-100mm	8mm	21mm	27mm	100mm	36mm	M6 x 1.0P	16081C-20
29260	CAT50 x 10mm I.D.-100mm	10mm	24mm	32mm	100mm	42mm	M8 x 1.25P	16082C-20
29264	CAT50 x 12mm I.D.-100mm	12mm	24mm	32mm	100mm	47mm	M10 x 1.5P	16083C-20
29268	CAT50 x 14mm I.D.-100mm	14mm	27mm	34mm	100mm	47mm	M10 x 1.5P	16083C-20
29272	CAT50 x 16mm I.D.-100mm	16mm	27mm	34mm	100mm	50mm	M12 x 1.75P	16085C-20
29276	CAT50 x 18mm I.D.-100mm	18mm	33mm	42mm	100mm	50mm	M12 x 1.75P	16085C-20
29278-100	CAT50 x 20mm I.D.-100mm	20mm	33mm	42mm	100mm	52mm	M16 x 2.0P	16089C-20
29280	CAT50 x 25mm I.D.-100mm	25mm	44mm	53mm	100mm	58mm	M20 x 2.0P	16091C-20
29282	CAT50 x 32mm I.D.-100mm	32mm	44mm	53mm	100mm	58mm	M20 x 2.0P	16091C-20

CAT50 Extended Length Metric ShrinkFIT Holders

Part No.	Description	d1	d2	d3	L	l1	thread	coolant screw
29254	CAT50 x 6mm I.D.-150mm	6mm	21mm	27mm	150mm	36mm	M5 x 0.8P	16080C-20
29254-8	CAT50 x 6mm I.D.-203mm	6mm	21mm	27mm	203mm	36mm	M5 x 0.8P	16080C-20
29258	CAT50 x 8mm I.D.-150mm	8mm	21mm	27mm	150mm	36mm	M6 x 1.0P	16081C-20
29258-8	CAT50 x 8mm I.D.-203mm	8mm	21mm	27mm	203mm	36mm	M6 x 1.0P	16081C-20
29262	CAT50 x 10mm I.D.-150mm	10mm	24mm	32mm	150mm	42mm	M8 x 1.25P	16082C-20
29266	CAT50 x 12mm I.D.-150mm	12mm	24mm	32mm	150mm	47mm	M10 x 1.5P	16083C-20
29266-8	CAT50 x 12mm I.D.-203mm	12mm	24mm	32mm	203mm	47mm	M10 x 1.5P	16083C-20
29270	CAT50 x 14mm I.D.-150mm	14mm	27mm	34mm	150mm	47mm	M10 x 1.5P	16083C-20
29274	CAT50 x 16mm I.D.-160mm	16mm	27mm	34mm	160mm	50mm	M12 x 1.75P	16085C-20
NEW 29278-160	CAT50 x 20mm I.D.-160mm	20mm	33mm	42mm	160mm	52mm	M16 x 2.0P	16089C-20
NEW 29280-160	CAT50 x 25mm I.D.-160mm	25mm	44mm	53mm	160mm	52mm	M20 x 2.0P	16091C-20



CAT50 Precision CoolBLAST ShrinkFIT Toolholders



Techniks Certified for accuracy and balance

CoolBLAST features a 3° angle to better direct coolant on the cutting tool.



CoolBLAST coolant ports direct coolant on the tool path, even at high RPMs. No need to purchase coolant-thru cutting tools.

CoolBLAST Features

- Maximum chip removal for maximum feed rates
- Balanced 25,000 RPM at G2.5
- Comes with coolant-thru set screw installed



3-port design features smaller coolant holes for increased pressure & easier tool removal.



ShrinkFIT Machines
pg. 116



ShrinkFIT Extensions
pg. 115



Retention Knobs
pg. 228



Wrenches
pg. 232

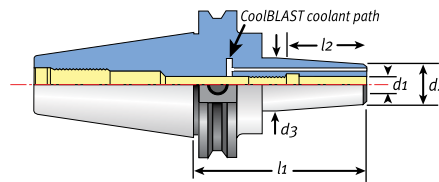

Coolant-thru set screw included. Page 115 for dimensions.



CAT50 CoolBLAST ShrinkFIT Holders

Part No.	Description	d1	d2	d3	L	l1	thread	coolant screw
29252B	CAT50 x 6mm - 100mm CoolBlast	6mm	0.83"	1.06"	100mm	1.42"	M5 x 0.8P	16080C-20
29054B	CAT50 x 1/4" - 3.54" with CoolBLAST	1/4"	0.71"	0.98"	3.54"	1.42"	M5 x 0.8P	16080C-20
29058B	CAT50 x 3/8" - 3.94" with CoolBLAST	3/8"	0.94"	1.26"	3.94"	1.42"	M8 x 1.25P	16082C-20
29260B	CAT50 x 10mm - 100mm w/ CoolBlast	10mm	0.94"	1.26"	100mm	1.42"	M8 x 1.25P	16082C-20
29060B	CAT50 x 1/2" - 3.94" with CoolBLAST	1/2"	1.10"	1.34"	3.94"	1.85"	M10 x 1.5P	16083C-20
29062B	CAT50 x 5/8" - 3.94" with CoolBLAST	5/8"	1.06"	1.34"	3.94"	1.97"	M12 x 1.75P	16085C-20
29064B	CAT50 x 3/4" - 4.13" with CoolBLAST	3/4"	1.42"	1.65"	4.13"	2.04"	M16 x 2.0P	16089C-20
29068B	CAT50 x 1" - 4.13" with CoolBLAST	1"	1.81"	2.09"	4.13"	2.28"	M20 x 2.0P	16091C-20
29072B	CAT50 x 1-1/4" - 4.13" w/ CoolBLAST	1-1/4"	1.81"	2.09"	4.13"	2.28"	M20 x 2.0P	16091C-20

Blue indicates coolant.

CAT50 Extended Length CoolBLAST ShrinkFIT Holders

Part No.	Description	d1	d2	d3	L	l1	thread	coolant screw
29054-6B	CAT50 x 1/4" - 6" with CoolBLAST	1/4"	0.71"	1.06"	6"	1.42"	M5 x 0.8P	16080C-20
29058-6B	CAT50 x 3/8" - 6" with CoolBLAST	3/8"	0.94"	1.26"	6"	1.65"	M8 x 1.25P	16082C-20
29060-6B	CAT50 x 1/2" - 6" with CoolBLAST	1/2"	1.10"	1.34"	6"	1.85"	M10 x 1.5P	16083C-20
29062-6B	CAT50 x 5/8" - 6" with CoolBLAST	5/8"	1.06"	1.34"	6"	1.97"	M12 x 1.75P	16085C-20
29066B	CAT50 x 3/4" - 6" with CoolBLAST	3/4"	1.42"	1.65"	6"	2.04"	M16 x 2.0P	16089C-20
29070B	CAT50 x 1" - 6" with CoolBLAST	1"	1.81"	2.09"	6"	2.28"	M20 x 2.0P	16091C-20

Blue indicates coolant.

BT30 ShrinkFIT & DualDRIVE for Dual-Contact Spindles



Techniks Certified for accuracy and balance

Features

- Maximum T.I.R. only 0.0001"
- Balanced 25,000 RPM at G2.5
- Comes with coolant-thru set screw installed

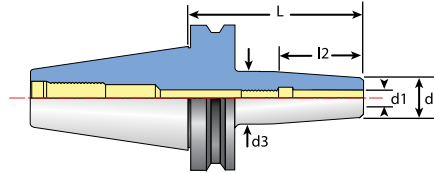

Coolant-thru set screw included. Page 115 for dimensions.



BT30 ShrinkFIT Holders

Part No.	Description	d1	d2	d3	L	l2	thread	coolant screw
67250	BT30 x 1/4" I.D. - 3"	1/4"	0.82"	1.06"	3"	1.42"	M5 x 0.8P	16082C-20
67375	BT30 x 3/8" I.D. - 3"	3/8"	0.94"	1.25"	3"	1.42"	M8 x 1.25P	16082C-20
67500	BT30 x 1/2" I.D. - 3"	1/2"	0.94"	1.25"	3"	1.85"	M10 x 1.5P	16083C-20
67625	BT30 x 5/8" I.D. - 3"	5/8"	1.06"	1.33"	3"	1.97"	M12 x 1.75P	16085C-20
67750	BT30 x 3/4" I.D. - 3"	3/4"	1.29"	1.62"	3"	2.04"	M16 x 2.0P	16089C-20



Techniks Certified for accuracy and balance

Features

- Designed for dual-contact spindles
- Coolant-thru spindle or thru flange (DIN B) (comes with coolant-thru set screw installed)
- Balanced to 25,000 RPM at G2.5

Benefits

- Better rigidity and reduced vibration (chatter)
- Improved performance at high metal removal rates and when machining at extended lengths

BT30 DualDRIVE ShrinkFIT Holders

Part No.	Description	d1	d2	d3	L	l2	thread	coolant screw
25.651.54.300	BT30 x 1/4" I.D. - 3" DualDRIVE	1/4"	.83"	1.06"	3"	1.42"	M8 x 1.25P	16082C-20
25.651.56.300	BT30 x 3/8" I.D. - 3" DualDRIVE	3/8"	.94"	1.26"	3"	1.42"	M8 x 1.25P	16082C-20
25.651.58.300	BT30 x 1/2" I.D. - 3" DualDRIVE	1/2"	.94"	1.26"	3"	1.85"	M10 x 1.5P	16083C-20
25.651.61.300	BT30 x 5/8" I.D. - 3" DualDRIVE	5/8"	1.06"	1.34"	3"	1.97"	M12 x 1.75P	16085C-20
25.651.64.300	BT30 x 3/4" I.D. - 3" DualDRIVE	3/4"	1.30"	1.62"	3"	2.04"	M16 x 2.0P	16089C-20

Dual-Contact Spindles

Use Techniks DualDRIVE holders if your machine has a dual-contact spindle. Dual-Contact is a spindle option offered by some machine tool builders.

Dual-contact means both the toolholder taper and the flange make contact with the spindle. Dual-contact increases rigidity and accuracy during machining.

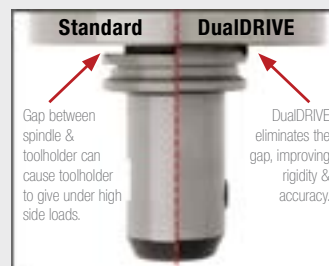

Gap between spindle & toolholder can cause toolholder to give under high side loads.

DualDRIVE eliminates the gap, improving rigidity & accuracy.



See our demonstration video of DualDRIVE at: <http://ow.ly/sUOqL>

BT40 Precision ShrinkFIT Toolholders



Techniks Certified for accuracy and balance

Features

- Maximum T.I.R. only 0.0001"
- Balanced 25,000 RPM at G2.5
- Comes with coolant-thru set screw installed

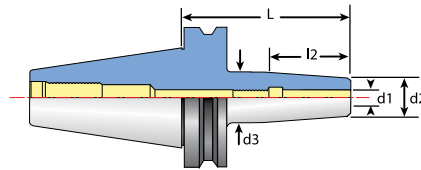

Coolant-thru set screw included. Page 115 for dimensions.



BT40 ShrinkFIT Holders Inch Size

Part No.	Description	d1	d2	d3	L	l2	thread	coolant screw
39110	BT40 x 3/16" I.D. - 3.54	3/16"	.43"	.75"	6"	.79"	M6 x 1.0P	16081C-20
39111	BT40 x 1/4" I.D. - 3.54	1/4"	.82"	1.06"	6"	1.42"	M5 x 0.8P	16080C-20
39113	BT40 x 3/8" I.D. - 3.54	3/8"	.94"	1.25"	6"	1.65"	-	16082C-20
39114	BT40 x 1/2" I.D. - 3.54	1/2"	1.10"	1.34"	6"	1.85"	M10 x 1.5P	16083C-20
19029	BT40 x 5/8" I.D. - 3.54	5/8"	1.06"	1.34"	6"	1.96"	M12 x 1.75P	16089C-20
39115	BT40 x 3/4" I.D. - 3.54	3/4"	1.29"	1.65"	6"	2.04"	M16 x 2.0P	16085C-20
39117	BT40 x 1.0" I.D. - 3.54	1.0"	1.73"	2.08"	6"	2.28"	M20 x 2.0P	16089C-20
39119-4.13	BT40 x 1-1/4" I.D. - 4.13	1-1/4"	1.81"	2.08"	6"	2.28"	M20 x 2.0P	16091C-20

BT40 Extended Length ShrinkFIT Holders

Part No.	Description	d1	d2	d3	L	l2	thread	coolant screw
19019-6	BT40 x 1/8" I.D. - 6"	1/8"	.36"	.63"	6"	0.70"	M6 x 1.0P	16081C-20
19020-6	BT40 x 3/16" I.D. - 6"	3/16"	.43"	.70"	6"	0.79"	M6 x 1.0P	16081C-20
19022-6	BT40 x 1/4" I.D. - 6"	1/4"	.49"	.83"	6"	1.42"	M5 x 0.8P	16080C-20
19026-6	BT40 x 3/8" I.D. - 6"	3/8"	.61"	.94"	6"	1.65"	M8 x 1.25P	16082C-20
19028-6	BT40 x 1/2" I.D. - 6"	1/2"	.74"	1.06"	6"	1.85"	M10 x 1.5P	16083C-20
19030-6	BT40 x 5/8" I.D. - 6"	5/8"	1.06"	1.34"	6"	1.96"	M12 x 1.75P	16085C-20
19032-6	BT40 x 3/4" I.D. - 6"	3/4"	1.29"	1.65"	6"	1.65"	M16 x 2.0P	16089C-20
19034-6	BT40 x 1" I.D. - 6"	1"	1.73"	2.09"	6"	2.28"	M20 x 2.0P	16091C-20

BT40 ShrinkFIT Holders Metric Size

Part No.	Description	d1	d2	d3	L	l2	thread	coolant screw
19136-135	BT40 x 6mm I.D. - 135mm	6mm	12mm	26mm	135mm	36mm	M5 x 0.8P	16080C-20
19138	BT40 x 8mm I.D. - 90mm	8mm	21mm	26mm	90mm	36mm	M6 x 1.0P	16081C-20
19138-135	BT40 x 8mm I.D. - 135mm	8mm	14mm	36mm	135mm	36mm	M6 x 1.0P	16081C-20
19140	BT40 x 10mm I.D. - 90mm	10mm	24mm	29mm	90mm	36mm	M8 x 1.25P	16082C-20
19140-135	BT40 x 10mm - I.D. 135mm	10mm	16mm	36mm	135mm	42mm	M8 x 1.25P	16082C-20
19142	BT40 x 12mm - I.D. 90mm	12mm	24mm	29mm	90mm	47mm	M10 x 1.5P	16083C-20
19142-135	BT40 x 12mm - I.D. 135mm	12mm	15mm	29mm	135mm	47mm	M10 x 1.5P	16083C-20

HSK40E, 50E Precision ShrinkFIT Holders



Features

- Maximum T.I.R. only 0.0001"
- Balanced 25,000 RPM at G2.5
- Coolant-thru set screw installed



Techniks Certified for accuracy and balance

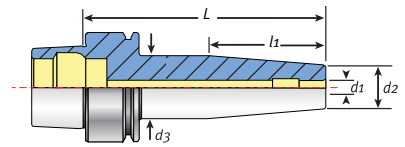

HSK40E Inch Size ShrinkFIT Holders

Part No.	Description	d1	d2	d3	L	l2	thread	coolant screw
39001-E	HSK40E x 1/8" I.D. - 3.54"	1/8"	.36"	.47"	3.54"	.79"	-	16081C-20
39002-E	HSK40E x 3/16" I.D. - 3.54"	3/16"	.63"	.71"	3.54"	.79"	-	16081C-20
39004-E	HSK40E x 1/4" I.D. - 3.54"	1/4"	.71"	1.06"	3.54"	1.42"	M5 x 0.8P	16080C-20
39006-E	HSK40E x 5/16" I.D. - 3.54"	5/16"	.83"	1.06"	3.54"	1.42"	M6 x 1.0P	16081C-20
39008-E	HSK40E x 3/8" I.D. - 3.54"	3/8"	.94"	1.26"	3.54"	1.65"	M8 x 1.25P	16082C-20

HSK40E Metric Size ShrinkFIT Holders

Part No.	Description	d1	d2	d3	L	l2	thread	coolant screw
39082-E	HSK40E x 3mm I.D. - 80mm	3mm	9mm	18mm	80mm	18mm	-	16081C-20
39084-E	HSK40E x 4mm I.D. - 80mm	4mm	10mm	22mm	80mm	20mm	-	16081C-20
39088-E	HSK40E x 6mm I.D. - 80mm	6mm	21mm	27mm	80mm	36mm	M5 x 0.8P	16080C-20
39090-E	HSK40E x 8mm I.D. - 80mm	8mm	21mm	27mm	80mm	36mm	M6 x 1.0P	16081C-20
39092-E	HSK40E x 10mm I.D. - 80mm	10mm	24mm	32mm	85mm	42mm	M8 x 1.25P	16082C-20



Use SlimLINE holders for finish passes where small nose diameter (d2) tooling is required.

Features

- Smaller nose diameter (d2)
- Maximum T.I.R. only 0.0001"
- Balanced 25,000 RPM at G2.5

Coolant-thru set screw included. Page 115 for dimensions.



HSK40E SlimLINE ShrinkFIT Holders

Part No.	Description	d1	d2	d3	L	l2	thread	coolant screw
99528	HSK40E x 1/8" I.D. - 2.36" SlimLINE	1/8"	.36"	.63"	2.36"	.78"	M6 x 1.0P	16081C-20
99538	HSK40E x 3/16" I.D. - 2.36" SlimLINE	3/16"	.43"	.69"	2.36"	.78"	M6 x 1.0P	16081C-20
99548	HSK40E x 1/4" I.D. - 2.36" SlimLINE	1/4"	.47"	.81"	2.36"	1.42"	M5 x 0.8P	16080C-20
99568	HSK40E x 3/8" I.D. - 2.36" SlimLINE	3/8"	.63"	.94"	2.36"	1.65"	M8 x 1.25P	16082C-20
99588	HSK40E x 1/2" I.D. - 2.36" SlimLINE	1/2"	.71"	1.06"	2.36"	1.85"	M10 x 1.5P	16083C-20

HSK50E ShrinkFIT Holders

Part No.	Description	d1	d2	d3	L	l2	thread	coolant screw
39014-E	HSK50E x 1/8" I.D. - 3.15"	1/8"	.36"	.87"	3.15"	.79"	M6 x 1.0P	16081C-20
39016-E	HSK50E x 3/16" I.D. - 3.54"	3/16"	.43"	.87"	3.54"	.79"	M6 x 1.0P	16081C-20
39018-E	HSK50E x 1/4" I.D. - 3.54"	1/4"	.71"	1.06"	3.54"	1.42"	M5 x 0.8P	16080C-20
39020-E	HSK50E x 5/16" I.D. - 3.54"	5/16"	.83"	1.06"	3.54"	1.42"	M6 x 1.0P	16081C-20
39022-E	HSK50E x 3/8" I.D. - 3.54"	3/8"	.94"	1.26"	3.54"	1.65"	M8 x 1.25P	16082C-20
39024-E	HSK50E x 1/2" I.D. - 3.54"	1/2"	1.10"	1.34"	3.54"	1.85"	M10 x 1.5P	16083C-20
39025-E	HSK50E x 5/8" I.D. - 3.54"	5/8"	1.06"	1.34"	3.54"	.97"	M12 x 1.75P	16085C-20



HSK63A Precision ShrinkFIT Holders



Features

- Maximum T.I.R. only 0.0001"
- Balanced 25,000 RPM at G2.5
- Comes with coolant-thru set screw installed



Techniks Certified for accuracy and balance

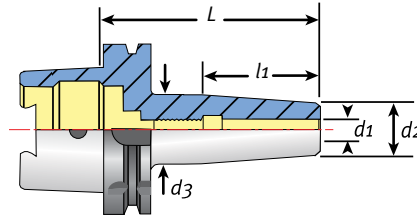

Coolant-thru set screw included. Page 115 for dimensions.



HSK63A Inch Size ShrinkFIT Toolholders

Part No.	Description	d1	d2	d3	L	l1	thread	coolant screw
93115	HSK63A x 1/4" I.D. - 3.15"	1/4"	.83"	1.06"	3.15"	1.42"	M5 x 0.8P	16082C-20
93116	HSK63A x 5/16" I.D. - 3.15"	5/16"	.83"	1.06"	3.15"	1.42"	M6 x 1.0P	16082C-20
93117	HSK63A x 3/8" I.D. - 3.35"	3/8"	.94"	1.26"	3.35"	1.65"	M8 x 1.25P	16082C-20
93118	HSK63A x 7/16" I.D. - 3.54"	7/16"	.94"	1.26"	3.54"	1.85"	M8 x 1.25P	16082C-20
93119	HSK63A x 1/2" I.D. - 3.54"	1/2"	.94"	1.26"	3.54"	1.85"	M10 x 1.5P	16083C-20
93120	HSK63A x 9/16" I.D. - 3.54"	9/16"	1.06"	1.34"	3.54"	1.85"	M10 x 1.5P	16083C-20
93121	HSK63A x 5/8" I.D. - 3.74"	5/8"	1.06"	1.34"	3.74"	1.97"	M12 x 1.75P	16085C-20
93124	HSK63A x 3/4" I.D. - 3.94"	3/4"	1.30"	1.65"	3.94"	2.05"	M16 x 2.0P	16089C-20
93126	HSK63A x 1.0" I.D. - 4.53"	1.0"	1.73"	2.05"	4.53"	2.28"	M20 x 2.0P	16091C-20
93128	HSK63A x 1-1/4" I.D. - 4.72"	1-1/4"	1.73"	2.09"	4.72"	2.28"	M20 x 2.0P	16091C-20

HSK63A Extended Length ShrinkFIT Toolholders

Part No.	Description	d1	d2	d3	L	l1	thread	coolant screw
93130	HSK63A x 3/8" I.D. - 6.3"	3/8"	.94"	1.26"	6.3"	1.65"	M8 x 1.25P	16082C-20
93135	HSK63A x 1/2" I.D. - 6.3"	1/2"	.94"	1.10"	6.3"	1.85"	M10 x 1.5P	16083C-20
93140	HSK63A x 3/4" I.D. - 6.3"	3/4"	1.42"	1.65"	6.3"	2.05"	M16 x 2.0P	16089C-20
93145	HSK63A x 1.0" I.D. - 6.3"	1.0"	1.73"	2.09"	6.3"	2.28"	M20 x 2.0P	16091C-20



SlimLINE Features

- Smaller nose diameter (d2)
- Maximum T.I.R. only 0.0001"
- Balanced 25,000 RPM at G2.5

Use SlimLINE holders for finish passes where small nose diameter (d2) tooling is required.



Coolant-thru set screw included. Page 115 for dimensions.

HSK63A SlimLINE ShrinkFIT Holders

Part No.	Description	d1	d2	d3	L	l1	thread	coolant screw
73528	HSK63A x 1/8" I.D. - 3.15" SlimLINE	1/8"	.35"	.63"	3.15"	.78"	M6x1.0P	16081C-20
73538	HSK63A x 3/16" I.D. - 3.15" SlimLINE	3/16"	.43"	.69"	3.15"	.78"	M6x1.0P	16081C-20
73548	HSK63A x 1/4" I.D. - 3.15" SlimLINE	1/4"	.47"	.81"	3.15"	1.42"	M5x0.8P	16080C-20
73568	HSK63A x 3/8" I.D. - 3.15" SlimLINE	3/8"	.63"	.94"	3.15"	1.65"	M8x1.25P	16082C-20
73588	HSK63A x 1/2" I.D. - 3.15" SlimLINE	1/2"	.71"	1.06"	3.15"	1.85"	M10x1.5P	16083C-20

HSK63A Precision ShrinkFIT Holders



Techniks Certified for accuracy and balance

Features

- Maximum T.I.R. only 0.0001"
- Balanced 25,000 RPM at G2.5
- Coolant-thru set screw installed

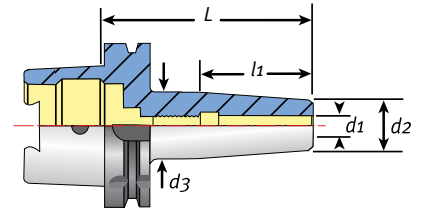

HSK63A Metric Size ShrinkFIT Toolholders

Part No.	Description	d1	d2	d3	L	l1	thread	coolant screw
39132	HSK63A x 4mm I.D. - 80mm	4mm	10mm	22mm	80mm	20mm	M6 x 1.0P	16082C-20
39134	HSK63A x 5mm I.D. - 80mm	5mm	16mm	22mm	80mm	20mm	M6 x 1.0P	16082C-20
39136	HSK63A x 6mm I.D. - 80mm	6mm	21mm	27mm	80mm	36mm	M5 x 0.8P	16082C-20
39138	HSK63A x 8mm I.D. - 80mm	8mm	21mm	27mm	80mm	36mm	M6 x 1.0P	16082C-20
39140	HSK63A x 10mm I.D. - 85mm	10mm	24mm	32mm	85mm	42mm	M8 x 1.25P	16082C-20
39142	HSK63A x 12mm I.D. - 90mm	12mm	24mm	32mm	90mm	47mm	M10 x 1.5P	16083C-20
39144	HSK63A x 14mm I.D. - 90mm	14mm	27mm	34mm	90mm	47mm	M10 x 1.5P	16083C-20
39146	HSK63A x 16mm I.D. - 95mm	16mm	27mm	34mm	95mm	50mm	M12 x 1.75P	16085C-20
39148	HSK63A x 18mm I.D. - 95mm	18mm	33mm	42mm	95mm	50mm	M12 x 1.75P	16085C-20
39150	HSK63A x 20mm I.D. - 100mm	20mm	33mm	42mm	100mm	52mm	M16 x 2.0P	16089C-20
39152	HSK63A x 25mm I.D. - 115mm	25mm	44mm	53mm	115mm	58mm	M20 x 2.0P	16091C-20
39154	HSK63A x 32mm I.D. - 120mm	32mm	44mm	53mm	120mm	58mm	M20 x 2.0P	16091C-20



CoolBLAST Features

- Maximum chip removal and feed rates
- Balanced 25,000 RPM at G2.5
- Coolant-thru set screw installed



3-port design features smaller coolant holes for increased pressure & easier tool removal.

HSK63A Inch Size CoolBLAST ShrinkFIT Toolholders

Part No.	Description	d1	d2	d3	L	l1	thread	coolant screw
93113B	HSK63A x 1/8" I.D. - 3.15" with CoolBLAST	1/8"	.63"	.87"	3.15"	.79"	M6x1.0P	16081C-20
93114B	HSK63A x 3/16" I.D. - 3.15" with CoolBLAST	3/16"	.63"	.87"	3.15"	.79"	M6 x 1.0P	16082C-20
93115B	HSK63A x 1/4" I.D. - 3.15" with CoolBLAST	1/4"	.83"	1.06"	3.15"	1.42"	M5 x 0.8P	16082C-20
93115-6B	HSK63A x 1/4" I.D. - 6" with CoolBLAST	1/4"	.83"	1.06"	6"	1.42"	M5 x 0.8P	16082C-20
93117B	HSK63A x 3/8" I.D. - 3.35" with CoolBLAST	3/8"	.94"	1.26"	3.35"	1.65"	M8 x 1.25P	16082C-20
93117-6B	HSK63A x 3/8" I.D. - 6" with CoolBLAST	3/8"	.94"	1.26"	6"	1.65"	M8 x 1.25P	16082C-20
93119B	HSK63A x 1/2" I.D. - 3.54" with CoolBLAST	1/2"	1.110"	1.34"	3.54"	1.85"	M10 x 1.5P	16083C-20
93119-6B	HSK63A x 1/2" I.D. - 6" with CoolBLAST	1/2"	1.110"	1.34"	6"	1.85"	M10 x 1.5P	16083C-20
93121B	HSK63A x 5/8" I.D. - 3.74" with CoolBLAST	5/8"	1.06"	1.34"	3.74"	1.97"	M12 x 1.75P	16085C-20
93121-6B	HSK63A x 5/8" I.D. - 6" with CoolBLAST	5/8"	1.06"	1.34"	6"	1.97"	M12 x 1.75P	16085C-20
93124B	HSK63A x 3/4" I.D. - 3.94" with CoolBLAST	3/4"	1.30"	1.65"	3.94"	2.05"	M16 x 2.0P	16089C-20
93124-6B	HSK63A x 3/4" I.D. - 6" with CoolBLAST	3/4"	1.30"	1.65"	6"	2.05"	M16 x 2.0P	16089C-20
93126-6B	HSK63A x 1" I.D. - 6" with CoolBLAST	1"	1.42"	1.65"	6"	2.04"	M20 x 2.0P	16091C-20



HSK63F and HSK100A ShrinkFIT Toolholders



Features

- Maximum T.I.R. only 0.0001"
- Balanced 25,000 RPM at G2.5
- Comes with coolant-thru set screw installed

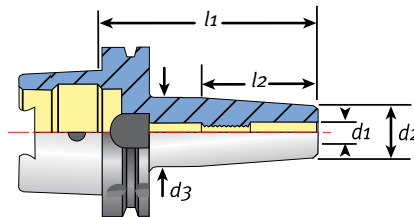

Order coolant-thru set screws separately. Page 115 for dimensions.



HSK63F Inch ShrinkFIT Toolholders

Part No.	Description	d1	d2	d3	l1	l2	thread	coolant screw
71250	HSK63F x 1/4" I.D. - 3.15"	1/4"	.83"	1.06"	3.15"	1.42"	M5 x 0.8P	16080C-20
71312	HSK63F x 5/16" I.D. - 3.74"	5/16"	.79"	1.06"	3.74"	1.42"	M6 x 1.0P	16081C-20
71375	HSK63F x 3/8" I.D. - 3.74"	3/8"	.94"	1.26"	3.74"	1.65"	M8 x 1.25P	16082C-20
71500	HSK63F x 1/2" I.D. - 3.74"	1/2"	.94"	1.26"	3.74"	1.85"	M10 x 1.5P	16083C-20
71625	HSK63F x 5/8" x 3.74"	5/8"	1.06"	1.34"	3.74"	1.97"	M12 x 1.75P	16085C-20
71750	HSK63F x 3/4" I.D. - 3.94"	3/4"	1.42"	1.65"	3.94"	2.05"	M16 x 2.0P	16089C-20
71100	HSK63F x 1.0" I.D. - 4.53"	1"	1.42"	1.65"	4.53"	2.28"	M20 x 2.0P	16091C-20

HSK63F Metric ShrinkFIT Toolholders

Part No.	Description	d1	d2	d3	l1	l2	thread	coolant screw
71010	HSK63F x 20mm I.D. - 100mm	20mm	33mm	42mm	100mm	47mm	M16 x 2.0P	16089C-20
71011	HSK63F x 25mm I.D. - 115mm	25mm	44mm	53mm	115mm	58mm	M20 x 2.0P	16091C-20

HSK100A ShrinkFIT Toolholders

Part No.	Description	d1	d2	d3	l1	l2	thread	coolant screw
39304	HSK100A x 1/8" I.D. - 90	1/8"	.35"	.87"	90	.79"	M6 x 1.0P	16081C-20
39306	HSK100A x 1/4" I.D. - 90	1/4"	.83"	1.06"	90	1.42"	M5 x 0.8P	16080C-20
NEW 39307	HSK 100A x 1/4" I.D. - 160	1/4"	.83"	1.06"	160	1.42"	M5 x 0.8P	16080C-20
39308	HSK100A x 5/16" I.D. - 85	5/16"	.79"	1.06"	85	1.42"	M6 x 1.0P	16081C-20
39310	HSK 100A x 3/8" I.D. - 90	3/8"	.94"	1.26"	90	1.65"	M8 x 1.25P	16082C-20
39310-6	HSK100A x 3/8" I.D. - 6"	3/8"	.94"	1.26"	6"	1.65"	M8 x 1.25P	16082C-20
NEW 39311	HSK 100A x 3/8" I.D. - 160	3/8"	.94"	1.26"	160	1.65"	M8 x 1.25P	16082C-20
39312	HSK100A x 7/16" I.D. - 95	7/16"	.94"	1.26"	95	1.85"	M10 x 1.5P	16083C-20
39314	HSK100A x 1/2" I.D. - 95	1/2"	1.10"	1.34"	95	1.85"	M10 x 1.5P	16083C-20
39315	HSK100A x 1/2" I.D. - 160	1/2"	1.10"	1.34"	160	1.85"	M10 x 1.5P	16083C-20
39318	HSK100A x 5/8" I.D. - 100	5/8"	1.06"	1.34"	100	1.97"	M12 x 1.75P	16085C-20
39319	HSK100A x 5/8" I.D. - 160	5/8"	1.26"	1.34"	160	1.97"	M12 x 1.75P	16085C-20
39320	HSK100A x 3/4" I.D. - 105	3/4"	1.42"	1.65"	105	2.04"	M16 x 2.0P	16089C-20
39321	HSK100A x 3/4" I.D. - 160	3/4"	1.42"	1.65"	160	2.04"	M16 x 2.0P	16089C-20
39324	HSK100A x 1.0" I.D. - 115	1.0"	1.81"	2.09"	115	2.28"	M20 x 2.0P	16091C-20
39325	HSK100A x 1.0" I.D. - 160	1.0"	1.81"	2.09"	160	2.28"	M20 x 2.0P	16091C-20
39326	HSK100A x 1-1/4" I.D. - 120	1-1/4"	1.81"	2.09"	120	2.28"	M20 x 2.0P	16091C-20
39327	HSK100A x 1-1/4" I.D. - 160	1-1/4"	1.81"	2.09"	160	2.28"	M20 x 2.0P	16091C-20

HSK100A CoolBLAST ShrinkFIT Toolholders



Techniks Certified for accuracy and balance

CoolBLAST Features

- Maximum chip removal for maximum feed rates
- Balanced 25,000 RPM at G2.5
- Comes with coolant-thru set screw installed



3-port design features smaller coolant holes for increased pressure & easier tool removal.



ShrinkFIT toolholders provide concentric clamping force of 10,000 lbs. or more directly on the cutting tool shank to reduce T.I.R. (runout). This allows operators to run faster and cutters last longer too.

CoolBLAST coolant ports direct coolant on the tool path, even at high RPMs. No need to purchase coolant-thru cutting tools.

CoolBLAST features a 3° angle to better direct coolant on the cutting tool.

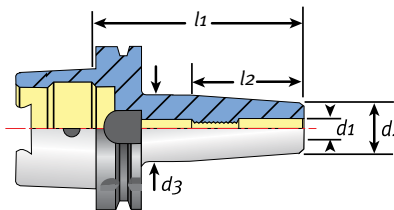

Coolant-thru set screw included. Page 115 for dimensions.



HSK100A ShrinkFIT CoolBLAST Toolholders

Part No.	Description	d1	d2	d3	l1	l2	thread
39306B	HSK 100A x 1/4" I.D. - 90 CoolBLAST	1/4"	.83"	1.06"	90	1.42"	M5 x 0.8P
39307B	HSK 100A x 1/4" I.D. - 160 CoolBLAST	1/4"	.83"	1.06"	160	1.42"	M5 x 0.8P
39310B	HSK 100A x 3/8" I.D. - 90 CoolBLAST	3/8"	.94"	1.26"	90	1.65"	M8 x 1.25P
39311B	HSK 100A x 3/8" I.D. - 160 CoolBLAST	3/8"	.94"	1.26"	160	1.65"	M8 x 1.25P
39314B	HSK 100A X 1/2" I.D. - 95 CoolBLAST	1/2"	1.10"	1.34"	95	1.85"	M10 x 1.5P
39315B	HSK 100A X 1/2" I.D. - 160 CoolBLAST	1/2"	1.10"	1.34"	160	1.85"	M10 x 1.5P
39318B	HSK 100A x 5/8" I.D. - 100mm CoolBLAST	5/8"	1.06"	1.34"	100	1.97"	M12 x 1.75P
39319B	HSK 100A x 5/8" I.D. - 160 CoolBLAST	5/8"	1.26"	1.34"	160	1.97"	M12 x 1.75P
39320B	HSK 100A x 3/4" I.D. - 105 CoolBLAST	3/4"	1.42"	1.65"	105	2.04"	M16 x 2.0P
39321B	HSK 100A x 3/4" I.D. - 160 CoolBLAST	3/4"	1.42"	1.65"	160	2.04"	M16 x 2.0P
39324B	HSK 100A x 1" I.D. - 115 CoolBLAST	1.0"	1.81"	2.09"	115	2.28"	M20 x 2.0P
39325B	HSK 100A x 1" I.D. - 160 CoolBLAST	1.0"	1.81"	2.09"	160	2.28"	M20 x 2.0P
39326B	HSK 100A x 1-1/4" I.D. - 120 CoolBLAST	1-1/4"	1.81"	2.09"	120	2.28"	M20 x 2.0P
39327B	HSK 100A x 1-1/4" - 160 CoolBLAST	1-1/4"	1.81"	2.09"	160	2.28"	M20 x 2.0P



Precision ShrinkFIT Toolholders for CNC Routers



Features

- Maximum T.I.R. only 0.0001"
- Balanced 25,000 RPM at G2.5
- Comes with coolant-thru set screw installed



Techniks Certified for accuracy and balance

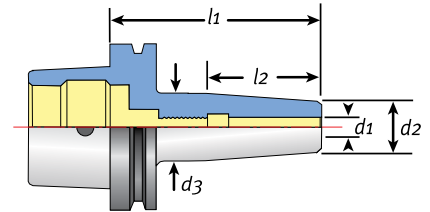

Order coolant-thru set screws separately. Page 115 for dimensions.



Scan the QR code with a smartphone or enter this url: <http://ow.ly/rKs6W> to request our new 76 page CNC Router Tooling catalog. Or, you can call us at (800) 597-3921 to have it sent to you.

HSK63F Inch ShrinkFIT Toolholders

Part No.	Description	d1	d2	d3	l1	l2	thread	coolant screw
71250	HSK63F x 1/4" I.D. - 3.15"	1/4"	.83"	1.06"	3.15"	1.42"	M5 x 0.8P	16080C-20
71312	HSK63F x 5/16" I.D. - 3.74"	5/16"	.79"	1.06"	3.74"	1.42"	M6 x 1.0P	16081C-20
71375	HSK63F x 3/8" I.D. - 3.74"	3/8"	.94"	1.26"	3.74"	1.65"	M8 x 1.25P	16082C-20
71500	HSK63F x 1/2" I.D. - 3.74"	1/2"	.94"	1.26"	3.74"	1.85"	M10 x 1.5P	16083C-20
71625	HSK63F x 5/8" x 3.74"	5/8"	1.06"	1.34"	3.74"	1.97"	M12 x 1.75P	16085C-20
71750	HSK63F x 3/4" I.D. - 3.94"	3/4"	1.42"	1.65"	3.94"	2.05"	M16 x 2.0P	16089C-20
71100	HSK63F x 1.0" I.D. - 4.53"	1"	1.42"	1.65"	4.53"	2.28"	M20 x 2.0P	16091C-20

HSK63F Metric ShrinkFIT Toolholders

Part No.	Description	d1	d2	d3	l1	l2	thread	coolant screw
71010	HSK63F x 20mm I.D. - 100mm	20mm	33mm	42mm	100mm	47mm	M16 x 2.0P	16089C-20
71011	HSK63F x 25mm I.D. - 115mm	25mm	44mm	53mm	115mm	58mm	M20 x 2.0P	16091C-20



ShrinkFIT toolholders provide concentric clamping force of 10,000 lbs. or more directly on the cutting tool shank to reduce T.I.R. (runout). This is why operators are able to run faster and cutters last longer too.

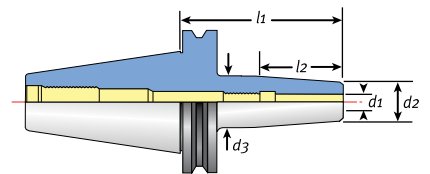

ISO30 ShrinkFIT Toolholders

Part No.	Description	d1	d2	d3	l1	l2	thread	coolant screw
64250	ISO30 x 1/4" - 80	1/4"	21	27	80	39	M5 x 0.8P	16082C-20
64375	ISO30 x 3/8" - 80	3/8"	24	32	80	42	M8 x 1.25P	16082C-20
64500	ISO30 x 1/2" - 80	1/2"	28	32	80	47	M10 x 1.5P	16083C-20
64625	ISO30 x 5/8" - 80	5/8"	28	32	80	50	M12 x 1.75P	16085C-20
64750	ISO30 x 3/4" - 80	3/4"	33	42	80	52	M16 x 2.0P	16089C-20
64110	ISO30 x 1.0" - 4"	1.0"	46	53	4"	58	M20 x 2.0P	16091C-20



NEW

SFS12 ShrinkFIT Holders & Adapters

SFS12 Shrink Adapters provide excellent accuracy and clearance at extended lengths. A great choice for mold & die applications.



Features

- T.I.R 0.0001" measured from the taper to the I.D.
- Balanced to 25,000 RPM @ G2.5
- Compatible with other modular shrink fit systems
- Coolant thru capable

How It Works

SFS toolholders feature a powerful internal drawbar design for maximum holding power and accuracy.

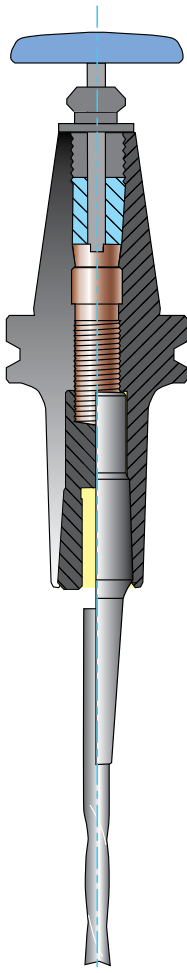

- H13 tool steel for easy tool changes
- Compatible with other holders
- Coolant thru capable

Advantages of H13 Tool Steel

SFS toolholders and ShrinkFIT adapters are made from H13 tool steel for compatibility with fast induction heat shrink machines like Techniks ShrinkPRO that provide tool changes in only 3–5 seconds. Toolholders made from H13 also provide reduced wear and tear on the machine spindle when compared to stainless steel holders.

For shanks from 1/8" to 1/2" using ShrinkFIT adapters.

SFS12 CAT, BT, HSK SFS12 Holders



Features

- T.I.R 0.0001" measured from the taper to the I.D.
- Balanced to 25,000 RPM @ G2.5
- Compatible with other modular shrink fit systems
- Coolant thru capable

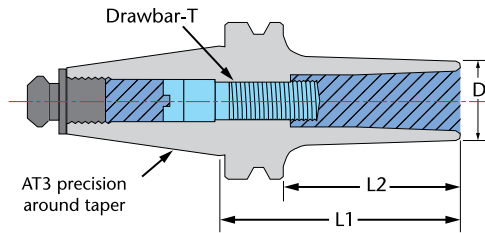

BT30 Retention Knobs for 10.780.12.138

Style	Part No.
45°	17817-MAS-1
60°	17806-MAS-2

Drawbar wrench requires coolant pull stud.

SFS Toolholders for CAT, BT, HSK

SFS toolholders feature a powerful internal drawbar design for maximum holding power and are coolant-thru capable.

Part No.	Description	L1	L2	D	Drawbar-T
10.780.12.138	BT30 x SFS12 - 1.38"	1.38"	0.51"	1.50"	See table above
11.780.12.045	BT40 x SFS12 - 1.77"	1.77"	0.71"	1.50"	SBL-M10C-25
31.780.12.177	CAT40 x SFS12 - 1.77"	1.77"	0.34"	1.61"	SBL-M10C-25
32.780.12.295	CAT50 x SFS12 - 2.95"	2.95"	1.46"	1.50"	SBL-M10C-25
99.780.12.075	HSK40E x SFS12 - 2.95"	2.95"	2.16"	1.50"	SFS-M10C-20.6
73.780.12.075	HSK63A x SFS12 - 2.95"	2.95"	1.85"	1.50"	SFS-M10C-20.6
103.780.12.065	HSK63F x SFS12 - 2.56"	2.56"	1.45"	1.50"	SFS-M10C-20.6
75.780.12.105	HSK100A x SFS12 - 4.13"	4.13"	1.85"	1.50"	SFS-M10C-20.6

Techniks SFS12 ShrinkFIT Adapters – Inch Size



Use with SFS Holders on page 112.

- H13 tool steel for easy tool changes
- Compatible with other holders
- Coolant thru capable

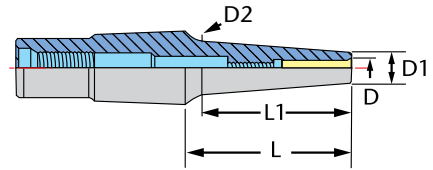

- H13 tool steel for easy tool changes
- Compatible with other holders
- Coolant thru capable

Inch Size SFS Adapters

Tighten to 44 ft/lbs

Part No.	Description	D	L	L1	D1	D2
258.SFS12.52.138	SFS 12 x 1/8" - 1.38"	1/8"	1.38"	.87"	.24"	.33"
258.SFS12.53.138	SFS 12 x 3/16" - 1.38"	3/16"	1.38"	.87"	.31"	.40"
258.SFS12.54.138	SFS 12 x 1/4" - 1.38"	1/4"	1.38"	.87"	.37"	.46"
258.SFS12.56.138	SFS 12 x 3/8" - 1.38"	3/8"	1.38"	.87"	.49"	.58"
258.SFS12.58.138	SFS 12 x 1/2" - 1.38"	1/2"	1.38"	.87"	.62"	.71"
258.SFS12.52.055	SFS 12 x 1/8" - 2.16"	1/8"	2.16"	1.65"	.24"	.41"
258.SFS12.52.055-3	SFS 12 x 1/8" - 2.16"	1/8"	2.16"	1.65"	.36"	.64"
258.SFS12.53.055	SFS 12 x 3/16" - 2.16"	3/16"	2.16"	1.65"	.30"	.48"
258.SFS12.54.055	SFS 12 x 1/4" - 2.16"	1/4"	2.16"	1.65"	.37"	.54"
258.SFS12.56.055	SFS 12 x 3/8" - 2.16"	3/8"	2.16"	1.65"	.49"	.66"
258.SFS12.58.055	SFS 12 x 1/2" - 2.16"	1/2"	2.16"	1.65"	.62"	.79"
258.SFS12.52.315	SFS 12 x 1/8" - 3.15"	1/8"	3.15"	2.64"	.24"	.52"
258.SFS12.53.315	SFS 12 x 3/16" - 3.15"	3/16"	3.15"	2.64"	.31"	.58"
258.SFS12.54.315	SFS 12 x 1/4" - 3.15"	1/4"	3.15"	2.64"	.37"	.64"
258.SFS12.56.315	SFS 12 x 3/8" - 3.15"	3/8"	3.15"	2.64"	.49"	.77"
258.SFS12.58.315	SFS 12 x 1/2" - 3.15"	1/2"	3.15"	2.64"	.62"	.89"
258.SFS12.52.433	SFS 12 x 1/8" - 4.33"	1/8"	4.33"	3.82"	.24"	.64"
258.SFS12.53.433	SFS 12 x 3/16" - 4.33"	3/16"	4.33"	3.82"	.31"	.71"
258.SFS12.54.433	SFS 12 x 1/4" - 4.33"	1/4"	4.33"	3.82"	.37"	.77"
258.SFS12.56.433	SFS 12 x 3/8" - 4.33"	3/8"	4.33"	3.82"	.49"	.89"
258.SFS12.58.433	SFS 12 x 1/2" - 4.33"	1/2"	4.33"	3.82"	.62"	1.02"

Techniks SFS12 ShrinkFIT Adapters – Metric Size



Use with SFS Holders on page 112.

- H13 tool steel for easy tool changes
- Compatible with other holders
- Coolant thru capable

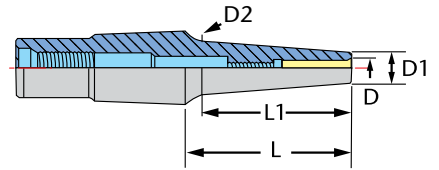

Metric Size SFS Adapters

Part No.	Description	D	L	L1	D1	D2
258.SFS12.03.035	SFS12 x 3mm - 35mm	3mm	35mm	22mm	6mm	8.3mm
258.SFS12.04.035	SFS12 x 4mm - 35mm	4mm	35mm	22mm	7mm	9.3mm
258.SFS12.06.035	SFS12 x 6mm - 35mm	6mm	35mm	22mm	9mm	11.3mm
258.SFS12.08.035	SFS12 x 8mm - 35mm	8mm	35mm	22mm	11mm	13.3mm
258.SFS12.10.035	SFS12 x 10mm - 35mm	10mm	35mm	22mm	13mm	15.3mm
258.SFS12.12.035	SFS12 x 12mm - 35mm	12mm	35mm	22mm	15mm	17.3mm
258.SFS12.03.055	SFS12 x 3mm - 55mm	3mm	55mm	42mm	6mm	10.4mm
258.SFS12.04.055	SFS12 x 4mm - 55mm	4mm	55mm	42mm	7mm	11.4mm
258.SFS12.06.055	SFS12 x 6mm - 55mm	6mm	55mm	42mm	9mm	13.4mm
258.SFS12.08.055	SFS12 x 8mm - 55mm	8mm	55mm	42mm	11mm	15.4mm
258.SFS12.10.055	SFS12 x 10mm - 55mm	10mm	55mm	42mm	13mm	17.4mm
258.SFS12.12.055	SFS12 x 12mm - 55mm	12mm	55mm	42mm	15mm	19.4mm
258.SFS12.03.080	SFS12 x 3mm - 80mm	3mm	80mm	67mm	6mm	13mm
258.SFS12.04.080	SFS12 x 4mm - 80mm	4mm	80mm	67mm	7mm	14mm
258.SFS12.06.080	SFS12 x 6mm - 80mm	6mm	80mm	67mm	9mm	16.2mm
258.SFS12.08.080	SFS12 x 8mm - 80mm	8mm	80mm	67mm	11mm	18mm
258.SFS12.10.080	SFS12 x 10mm - 80mm	10mm	80mm	67mm	13mm	20mm
258.SFS12.03.110	SFS12 x 3mm - 110mm	3mm	110mm	97mm	6mm	16.2mm
258.SFS12.04.110	SFS12 x 4mm - 110mm	4mm	110mm	97mm	7mm	17.2mm
258.SFS12.06.110	SFS12 x 6mm - 110mm	6mm	110mm	97mm	9mm	19.2mm
258.SFS12.08.110	SFS12 x 8mm - 110mm	8mm	110mm	97mm	11mm	21.2mm
258.SFS12.10.110	SFS12 x 10mm - 110mm	10mm	110mm	97mm	13mm	23.1mm
258.SFS12.12.110	SFS12 x 12mm - 110mm	12mm	110mm	97mm	15mm	25.2mm

Universal ShrinkFIT Extensions – Coolant Set Screws



For extended lengths
or tight clearances

Features

- Extend the reach of your existing holders
- Better rigidity and T.I.R. extends tool life
- Works with a variety of toolholders



ShrinkFIT extensions work
great with our 00400
ShrinkSTATION.

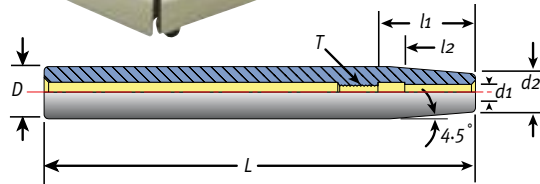

Metric sizes available upon request.

Part No.	Description	D	d1	d2	L	l1	l2	T
86062	5/8" O.D., x 1/8" I.D. - 6.3" length	5/8"	1/8"	.394"	6.3"	-	.39"	-
86064	5/8" O.D., x 3/16" I.D. - 6.3" length	5/8"	3/16"	.394"	6.3"	-	.39"	-
86066	5/8" O.D., x 1/4" I.D. - 6.3" length	5/8"	1/4"	.394"	6.3"	1.42	1.02"	M6x1.0
86076	3/4" O.D., x 1/4" I.D. - 6.3" length	3/4"	1/4"	.551"	6.3"	1.42	1.02"	M6x1.0
86080	3/4" O.D., x 3/8" I.D. - 6.3" length	3/4"	3/8"	.551"	6.3"	1.65	1.26"	M8x1.25
86090	1.0" O.D., x 3/8" I.D. - 6.3" length	1.0"	3/8"	.79"	6.3"	1.65	1.26"	M8x1.25
86092	1.0" O.D., x 1/2" I.D. - 6.3" length	1.0"	1/2"	.79"	6.3"	1.85	1.46"	M10x1.5
86094	1.0" O.D., x 5/8" I.D. - 6.3" length	1.0"	5/8"	.87"	6.3"	1.97	1.57"	M12x1.75

Coolant Set Screws

Part No.	Description	M	L	d
16080C-20	Coolant Set Screw	M5 x 0.8P	20mm	2.5
16081C-20	Coolant Set Screw	M6 x 1.0P	20mm	-
16082C-20	Coolant Set Screw	M8 x 1.25P	20mm	4
16083C-20	Coolant Set Screw	M10 x 1.5P	20mm	4
16085C-20	Coolant Set Screw	M12 x 1.75P	20mm	4
16089C-20	Coolant Set Screw	M16 x 02.0P	20mm	5
16091C-20	Coolant Set Screw	M20 x 2.0P	20mm	5

Blue indicates coolant.

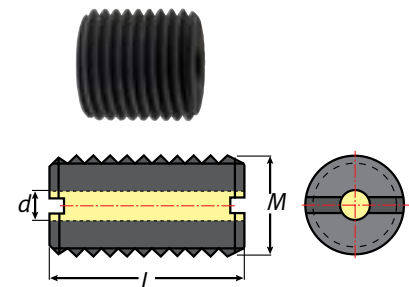

We stand behind all our products with our 100% Satisfaction Guarantee • www.techniksusa.com

ShrinkSTATION – ShrinkFIT Machine

NEW

Features

- Changes tools in 15–25 seconds (1/2" shank)
- Easy-to-Use touch screen controls
- Automatic cooling using 90 PSI shop air

The ShrinkSTATION is an ideal solution for job shops or manufacturing facilities that need a reliable shrink fit machine that can handle practically all sizes and types of toolholders, and is affordable.

This machine features many of the same processor and control technologies used in our ShrinkPRO machines. Every component of this machine from the industrial touch-screen interface, to the motor driven transport rail, and the heavy-duty stainless steel base, is designed for reliable performance and ease-of-use in demanding environments.

Ease-of-Use

- Use the touch screen to select your shank size, and the machine displays the default cycle time
- Change preset defaults for your tool changes
- Jog feature for easy height adjustments
- Tool moves to the optimum position for heating automatically



Designed and built in Indianapolis, IN.



select tool shank

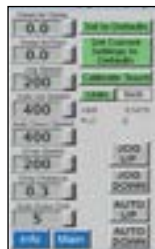

change default settings

The ShrinkSTATION includes everything you need to perform shrink fit tool changes on CAT40, CAT50, BT30, BT40, ISO30, HSK40, 50, 63 and 100, C4, C5, C6 toolholders with gauge lengths up to 22" (560mm).

It is designed to be used with carbide cutting tools from 1/8" up to 1-1/4" (3mm to 32mm).

NOTE: For shrinking tools made from high-speed steel (HSS) we recommend Model 00600 ShrinkPRO or 00500 Quencher machines.

ShrinkSTATION Includes:

Part No.	Description	QTY.
00400	induction heat shrink fit machine	1
00165	induction stop ring (3-5mm)	1
00166	induction stop ring (6-12mm)	1
00167	induction stop ring (14-20mm)	1
00301-01.4	induction stop ring (25-32mm)	1
00151	toolholder adapter - 30 taper	1
00152	toolholder adapter - 40 taper & C6	1
00153	toolholder adapter - 50 taper	1
00157	toolholder adapter - HSK40 & C4	1
00158	toolholder adapter - HSK50 & C5	1
00159	toolholder adapter - HSK63	1
	transport adapter for extended lengths	1
26139-L	thermal insulated glove	1

Part No.	Description	Tool Change	Cooling	Rating	L x D x H	Weight
00400	induction heat, air cool shrink fit machine	15–25 seconds	2 minutes	1 phase, 220V, 20A	16"x 16"x 22"	42 lbs

ShrinkPRO – High-Performance ShrinkFIT



20" wide x 20" deep x 37" tall

The ShrinkPRO is a great choice for dedicated tool changing stations or cellular workflows, because it can operate on voltages ranging from 208VAC thru 480VAC.

Features

- Change 1/8" shanks in 2 seconds. 1" in 6 seconds
- Flexible – Operates on 208V up to 480V
- Automatic cooling cycle by compressed air

Features and Flexibility

This machine truly has it all; touchscreen simplicity, state-of-the-art induction heating for fast tool changes, and automatic cooling cycle using your shop air.

Easy-to-Use Touchscreen



Select your shank size and ShrinkPRO sets heating duration

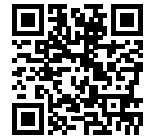

View the video.
<http://ow.ly/sVv3S>



Designed and built in Indianapolis, IN.

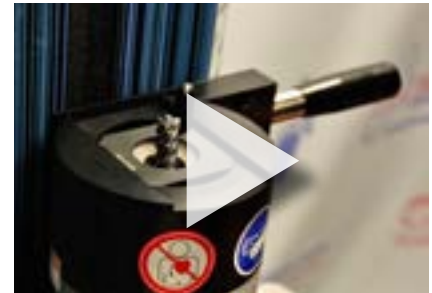

Scan the QR code to view the demo video.

Included With ShrinkPRO Machine

Part No.	Description	QTY.
TAR-BT30	30 taper adapter	1
TAR-CAT40	40 taper adapter	1
TAR-C6	50 taper adapter	1
TAR-HSK40	HSK40 adapter	1
TAR-HSK50	HSK50 adapter	1
TAR-HSK63-100	HSK63/100 adapter	1
26139-L	insulated glove	1
	Owners Manual	1

Part No.	Description	Tool Change	Rating	L x D x H	Ship Wt.
00600	ShrinkPRO machine	2–6 seconds	3 phase, 480V, 20A	20"x 20"x 37"	84 lbs

For HSK32 Adapter order Part No. 00156. For HSK80 Adapter order Part No. 00160.



“The Quencher” Cools Tools in Only 30 Seconds



Designed and built in Indianapolis, IN.



36.75" wide x 24" deep x 71" tall

Features

- Change tool and back to spindle in under 1 minute!
- Auto-Quench means you never touch hot toolholder
- Flexible – Operates on 208V up to 480V

The Quencher ShrinkFIT machine features a liquid cooling cycle that is 250% faster than air-cooled units. Cooling time is to less than 30 seconds!

The hot tool is immersed in the Quench Tank and the cool tool is returned to the shrink position in only 30 seconds and automatically dried using shop air.

The Quencher is a great choice for dedicated tool changing stations or cellular workflows, because it can operate on voltages from 208 - 480VAC.



View the demo video.
<http://ow.ly/u3JPK>

Touchscreen Simplicity



Select your shank size and the Quencher sets heating duration. Touch the Quench button to start cooling cycle.

The Quencher includes induction rings for 1/8" up to 1-1/4" shank sizes, tool seats for BT30/CAT30, BT40/CAT40, BT50/CAT50, and HSK40, 50, 63 and 100. No plumbing is required and the Quencher comes loaded with coolant.

Part No.	Description	Tool Change	Cooling Cycle	Rating	L x D x H	Ship Wt.
00500	ShrinkPRO Quencher	2–6 seconds	45 seconds	3 phase, 480V, 20A	37"x 24"x 71"	660 lbs

NOTE: 00500 includes same accessories as included with 00600 ShrinkPRO, plus coolant is pre-loaded. Owners man



“Never Down” Guarantee

We stand behind our products 100% and expect them to out-perform the competition. Purchase any Techniks ShrinkFIT machine with confidence knowing that we can provide a backup if yours should ever need servicing!

Replacement machine is on loan until original is repaired and back in service. Replacement machines are limited to standard configuration. Power requirements may vary from original machine. Replacements are subject to availability. Extended Warranties are also available.

Techniks Certified Face Mill Arbors

Manufactured from H13 tool steel for performance and long life.

NEW Extended Length Face Mill Arbors

- CAT40, CAT50 now up to 12" gauge lengths
- H6 arbor tolerance reduces chatter



CAT40-50, BT30-40-50, HSK63A-100A, R8

- Compatible with all face mills
- Use CoolBLAST arbor screws for high-pressure coolant



DualDRIVE for Dual Contact Spindles

- Techniks Certified for dual contact
- Compatible with standard spindles too



View the DualDRIVE video for face mill arbors.
<http://ow.ly/sUOqL>

CAT40 Precision Face Mill Arbors



Techniks Certified for accuracy

Features

- Compatible with all face mills
- H6 arbor tolerance for less chatter & better tool life
- Taper ground to AT3 tolerance or better



Arbor
Screws
pg. 128



Tightening
Stands
pg. 234



Retention
Knobs
pg. 228



Wrenches
pg. 232

CoolBLAST Coolant Option

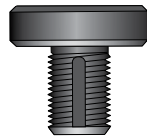

CoolBLAST arbor screw
provides coolant path.
Order on page 128.

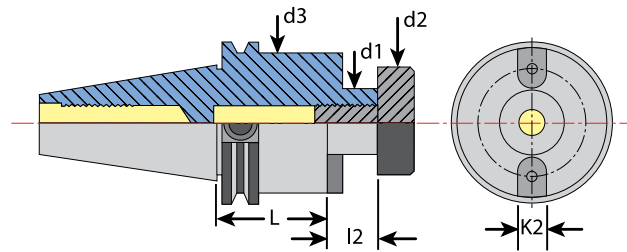

CAT40 Face Mill Arbors

Part No.	Description	L	I2	d1	d2	d3	K2
22709	CAT40 x FMA 1/2" - 1.37"	1.37"	.55"	1/2"	.66"	1.45"	.25"
22709-4	CAT40 x FMA 1/2" - 4"	4"	.55"	1/2"	.66"	1.45"	.25"
22711	CAT40 x FMA 3/4" - 1.37"	1.37"	.69"	3/4"	.88"	1.69"	.31"
22711-4	CAT40 x FMA 3/4" - 4.0"	4"	.69"	3/4"	.88"	1.69"	.31"
22711-6	CAT40 x FMA 3/4" - 6.0"	6"	.69"	3/4"	.88"	1.69"	.31"
NEW 22711-8	CAT40 x FMA 3/4" - 8.0"	8"	.69"	3/4"	.88"	1.69"	.31"
22713	CAT40 x FMA 1.0" - 2.06"	2.06"	.69"	1.0"	1.19"	2.2"	.38"
22713-4	CAT40 x FMA 1.0" - 4.0"	4"	.69"	1.0"	1.19"	2.2"	.38"
22713-6	CAT40 x FMA 1.0" - 6.0"	6"	.69"	1.0"	1.19"	2.2"	.38"
NEW 22713-8	CAT40 x FMA 1.0" - 6.0"	8"	.69"	1.0"	1.19"	2.2"	.38"
22715	CAT40 x FMA 1-1/4" - 2.21"	2.21"	.69"	1-1/4"	1.5"	2.75"	.5"
22715-4	CAT40 x FMA 1-1/4" - 4.0"	4"	.69"	1-1/4"	1.5"	2.75"	.5"
22715-6	CAT40 x FMA 1-1/4" - 6.0"	6"	.69"	1-1/4"	1.5"	3."	.5"
NEW 22715-8	CAT40 x FMA 1-1/4" - 8.0"	8"	.69"	1-1/4"	1.5"	3."	.5"
22717	CAT40 x FMA 1-1/2" - 2.21"	2.21"	.94"	1-1/2"	1.88"	3.8"	.63"
22717-4	CAT40 x FMA 1-1/2" - 4"	4"	.94"	1-1/2"	1.88"	3.8"	.63"

CAT40 DualDRIVE for Dual-Contact Spindles



Techniks Certified for accuracy

Features

- Techniks Certified for dual-contact spindles
- Compatible with all face mills
- H6 arbor tolerance for less chatter & better tool life

Benefits

- Better rigidity and reduced vibration
- Improved performance at high metal removal rates and when machining at extended lengths

CoolBLAST Coolant Option

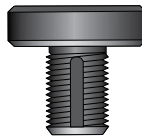

CoolBLAST arbor screw provides coolant path. Order on page 128.

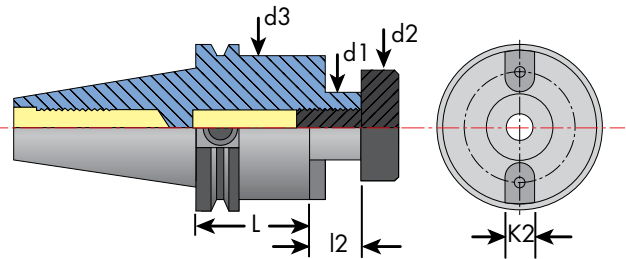

CAT40 DualDRIVE Face Mill Arbors

Part No.	Description	L	l2	d1	d2	d3	K2
43.151.64.137	CAT40 x FMA 3/4" - 1.37" DualDRIVE	1.37"	.69"	3/4"	.88"	1.69"	.31"
43.151.64.400	CAT40 x FMA 3/4" - 4" DualDRIVE	4"	.69"	3/4"	.88"	1.69"	.31"
43.151.64.600	CAT40 x FMA 3/4" - 6" DualDRIVE	6"	.69"	3/4"	.88"	1.69"	.31"
43.151.68.206	CAT40 x FMA 1.0" - 2.06" DualDRIVE	2.06"	.69"	1.0"	1.19"	2.2"	.38"
43.151.68.400	CAT40 x FMA 1.0" - 4" DualDRIVE	4"	.69"	1.0"	1.19"	2.2"	.38"
43.151.68.600	CAT40 x FMA 1.0" - 6" DualDRIVE	6"	.69"	1.0"	1.19"	2.2"	.38"
43.151.72.221	CAT40 x FMA 1-1/4" - 2.21" DualDRIVE	2.21"	.69"	1-1/4"	1.5"	2.75"	.5"
43.151.72.400	CAT40 x FMA 1-1/4" - 4" DualDRIVE	4"	.69"	1-1/4"	1.5"	2.75"	.5"
43.151.72.600	CAT40 x FMA 1-1/4" - 6" DualDRIVE	6"	.69"	1-1/4"	1.5"	3"	.5"
43.151.77.221	CAT40 x FMA 1-1/2" - 2.21" DualDRIVE	2.21"	.94"	1-1/2"	1.88"	3.8"	.63"
43.151.77.400	CAT40 x FMA 1-1/2" - 4" DualDRIVE	4"	.94"	1-1/2"	1.88"	3.8"	.63"

Dual-Contact Spindles

Use Techniks DualDRIVE holders if your machine has a dual-contact spindle. Dual-Contact is a spindle option offered by some machine tool builders.

Dual-contact means both the toolholder taper and the flange make contact with the spindle. Dual-contact increases rigidity and accuracy during machining.

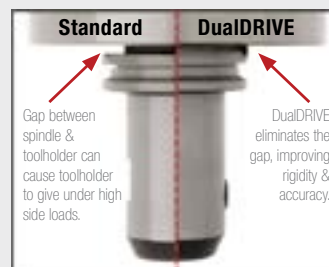

See our demonstration video of DualDRIVE at: <http://ow.ly/sUOqL>



CAT50 Precision Face Mill Arbors



Techniks Certified for accuracy

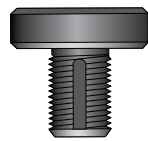

CoolBLAST arbor screw provides coolant path. Order on page 128.

Features

- Compatible with all face mills
- H6 arbor tolerance for less chatter & better tool life
- Taper ground to AT3 tolerance or better



Arbor
Screws
pg. 128



Tightening
Stands
pg. 234



Retention
Knobs
pg. 228



Wrenches
pg. 232

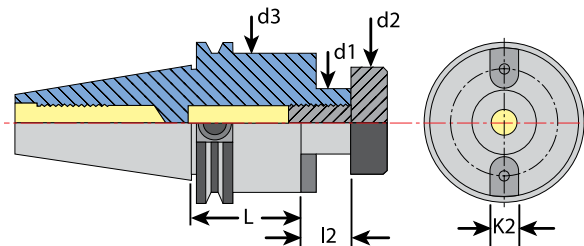

CAT50 Face Mill Arbors

Part No.	Description	L	l2	d1	d2	d3	K2
22719	CAT50 x FMA 1/2" - 1.5"	1.5"	.055"	1/2"	.66"	1.45"	.25"
22721	CAT50 x FMA 3/4" - 1.5"	1.5"	.69"	3/4"	.88"	2.75"	.31"
22721-3.5	CAT50 x FMA 3/4" - 3.5"	3.5"	.69"	3/4"	.88"	1.69"	.31"
22721-5.5	CAT50 x FMA 3/4" - 5.5"	5.5"	.69"	3/4"	.88"	1.69"	.31"
NEW 22721-8	CAT50 x FMA 3/4" - 8"	8"	.69"	3/4"	.88"	1.69"	.31"
NEW 22721-10	CAT50 x FMA 3/4" - 10"	10"	.69"	3/4"	.88"	1.69"	.31"
NEW 22721-12	CAT50 x FMA 3/4" - 12"	12"	.69"	3/4"	.88"	1.69"	.31"
22723	CAT50 x FMA 1" - 2.0"	2.0"	.69"	1.0"	1.19"	2.2"	.38"
22723-4	CAT50 x FMA 1" - 4.0"	4"	.69"	1.0"	1.19"	2.2"	.38"
22723-6	CAT50 x FMA 1" - 6.0"	6"	.69"	1.0"	1.19"	2.2"	.38"
22723-8	CAT50 x FMA 1" - 8.0"	8"	.69"	1.0"	1.19"	2.2"	.38"
NEW 22723-10	CAT50 x FMA 1" - 10.0"	10"	.69"	1.0"	1.19"	2.2"	.38"
NEW 22723-12	CAT50 x FMA 1" - 12.0"	12"	.69"	1.0"	1.19"	2.2"	.38"
22725	CAT50 x FMA 1-1/4" - 1.50"	1.5"	.69"	1-1/4"	1.5"	2.75"	.5"
22725-3.5	CAT50 x FMA 1-1/4" - 3.5"	3.5"	.69"	1-1/4"	1.5"	2.75"	.5"
22725-6	CAT50 x FMA 1-1/4" - 6.0"	6"	.69"	1-1/4"	1.5"	2.75"	.5"
22725-8	CAT50 x FMA 1-1/4" - 8.0"	8"	.69"	1-1/4"	1.5"	2.75"	.5"
NEW 22725-10	CAT50 x FMA 1-1/4" - 10.0"	10"	.69"	1-1/4"	1.5"	2.75"	.5"
NEW 22725-12	CAT50 x FMA 1-1/4" - 12.0"	12"	.69"	1-1/4"	1.5"	2.75"	.5"
22727	CAT50 x FMA 1-1/2" - 2.4"	2.4"	.94"	1-1/2"	1.88"	3.8"	.63"
22727-4	CAT50 x FMA 1-1/2" - 4.0"	4"	.94"	1-1/2"	1.88"	3.8"	.63"
22727-6	CAT50 x FMA 1-1/2" - 6.0"	6"	.94"	1-1/2"	1.88"	3.8"	.63"
22727-8	CAT50 x FMA 1-1/2" - 8.0"	8"	.94"	1-1/2"	1.88"	3.8"	.63"
22729	CAT50 x FMA 2" - 2.4"	2.4"	.94"	2"	2.5"	4.88"	.75"
22729-4	CAT50 x FMA 2" - 4.0"	4"	.94"	2"	2.5"	4.88"	.75"

CAT50 DualDRIVE for Dual-Contact Spindles



Techniks Certified for accuracy

Features

- Designed for dual-contact spindles
- Compatible with all face mills
- H6 arbor tolerance for less chatter & better tool life

Benefits

- Better rigidity and reduced vibration
- Improved performance at high metal removal rates and when machining at extended lengths

CoolBLAST Coolant Option

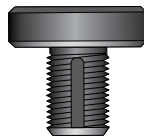

CoolBLAST arbor screw provides coolant path. Order on page 128.

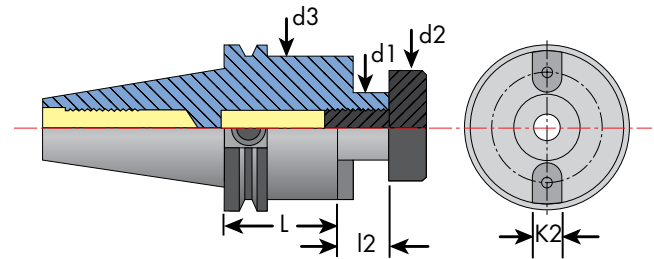

CAT50 DualDRIVE Face Mill Arbors

Part No.	Description	L	l2	d1	d2	d3	K2
44.151.64.150	CAT50 x FMA 3/4" - 1.5" DualDRIVE	1.5"	.69"	3/4"	.88"	2.75"	.31"
44.151.64.350	CAT50 x FMA 3/4" - 3.5" DualDRIVE	3.5"	.69"	3/4"	.88"	1.69"	.31"
44.151.64.550	CAT50 x FMA 3/4" - 5.5" DualDRIVE	5.5"	.69"	3/4"	.88"	1.69"	.31"
44.151.68.200	CAT50 x FMA 1.0" - 2" DualDRIVE	2"	.69"	1.0"	1.19"	2.2"	.38"
44.151.68.400	CAT50 x FMA 1.0" - 4" DualDRIVE	4"	.69"	1.0"	1.19"	2.2"	.38"
44.151.68.600	CAT50 x FMA 1.0" - 6" DualDRIVE	6"	.69"	1.0"	1.19"	2.2"	.38"
44.151.72.150	CAT50 x FMA 1-1/4" - 1.5" DualDRIVE	1.5"	.69"	1-1/4"	1.5"	2.75"	.5"
44.151.72.350	CAT50 x FMA 1-1/4" - 3.5" DualDRIVE	3.5"	.69"	1-1/4"	1.5"	2.75"	.5"
44.151.72.600	CAT50 x FMA 1-1/4" - 6" DualDRIVE	6"	.69"	1-1/4"	1.5"	2.75"	.5"
44.151.77.240	CAT50 x FMA 1-1/2" - 2.4" DualDRIVE	2.4"	.94"	1-1/2"	1.88"	3.8"	.63"
44.151.77.400	CAT50 x FMA 1-1/2" - 4" DualDRIVE	4"	.94"	1-1/2"	1.88"	3.8"	.63"
44.151.77.600	CAT50 x FMA 1-1/2" - 6" DualDRIVE	6"	.94"	1-1/2"	1.88"	3.8"	.63"
44.151.77.800	CAT50 x FMA 1-1/2" - 8" DualDRIVE	8"	.94"	1-1/2"	1.88"	3.8"	.63"
44.151.86.240	CAT50 x FMA 2" - 2.4" DualDRIVE	2.4"	.94"	2"	2.5"	4.88"	.75"
44.151.86.400	CAT50 x FMA 2" - 4" DualDRIVE	4"	.94"	2"	2.5"	4.88"	.75"

Dual-Contact Spindles

Use Techniks DualDRIVE holders if your machine has a dual-contact spindle. Dual-Contact is a spindle option offered by some machine tool builders.

Dual-contact means both the toolholder taper and the flange make contact with the spindle. Dual-contact increases rigidity and accuracy during machining.

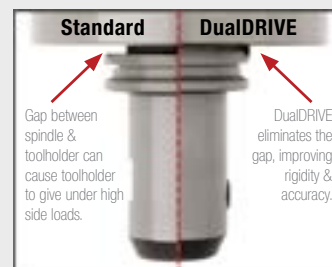

See our demonstration video of DualDRIVE at: <http://ow.ly/sUOqL>



BT30 Arbors & DualDRIVE for Dual-Contact Spindles



Features

- H6 arbor tolerance for less chatter & better tool life
- Each arbor lab certified for accuracy
- Taper ground to AT3 tolerance for maximum spindle contact

BT30 Precision Face Mill Arbors

Part No.	Description	L	I2	d1	d2	d3	K2
16611	BT30 x FMA 3/4" - 1.18"	1.18"	.69"	3/4"	.88"	1.66"	.313"
16612	BT30 x FMA 1" - 1.77"	1.77"	.69"	1.0"	1.18"	2.2"	.375"
16614	BT30 x FMA 1-1/4" - 1.77"	1.77"	.87"	1-1/4"	1.5"	2.37"	.5"



Techniks Certified for accuracy

Features

- Designed for dual-contact spindles
- Compatible with all face mills
- H6 arbor tolerance for less chatter & better tool life

Benefits

- Better rigidity and reduced vibration (chatter)
- Improved performance at high metal removal rates and when machining at extended lengths

CoolBLAST Coolant Option

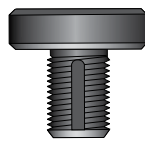

CoolBLAST arbor screw provides coolant path. Order on page 128.

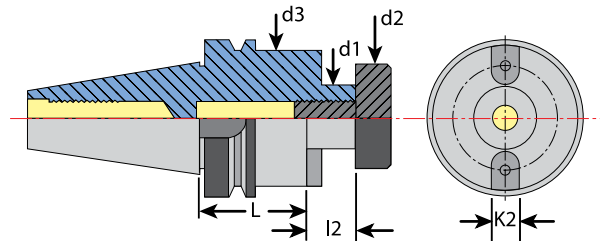

BT30 DualDRIVE Face Mill Arbors

Part No.	Description d1 – I1	L	I2	d1	d2	d3	K2
25.151.64.200	BT30 x DualDRIVE FMA 3/4" - 2"	2"	.69"	3/4"	.88"	1.66"	.313"
25.151.68.200	BT30 x DualDRIVE FMA 1.0" - 2"	2"	.69"	1.0"	1.18"	2.2"	.375"

Dual-Contact Spindles

Use Techniks DualDRIVE holders if your machine has a dual-contact spindle. Dual-Contact is a spindle option offered by some machine tool builders.

Dual-contact means both the toolholder taper and the flange make contact with the spindle. Dual-contact increases rigidity and accuracy during machining.

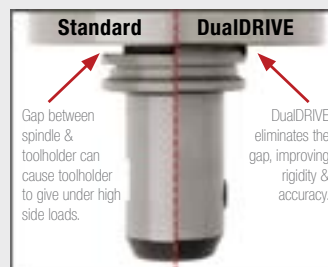

See our demonstration video of DualDRIVE at: <http://ow.ly/sUOqL>

BT40, BT50 Precision Face Mill Arbors



Techniks Certified for accuracy

Features

- Compatible with all face mills
- H6 arbor tolerance for less chatter & better tool life
- Taper ground to AT3 tolerance or better



Arbor
Screws
pg. 128



Tightening
Stands
pg. 234



Retention
Knobs
pg. 228



Wrenches
pg. 232

CoolBLAST Coolant Option

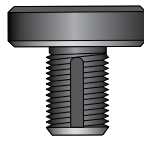

CoolBLAST arbor screw
provides coolant path.
Order on page 128.

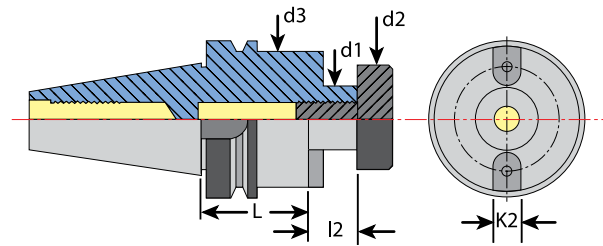

BT40 Face Mill Arbors

Part No.	Description	L	I2	d1	d2	d3	K2
16615-3/4	BT40 x FMA 3/4" - 1"	1.0"	.69"	3/4"	.88"	1.69"	.313"
16615-4	BT40 x FMA 3/4" - 4.0"	4"	.69"	3/4"	.88"	1.69"	.313"
16615-6	BT40 x FMA 3/4" - 6.0"	6"	.69"	3/4"	.88"	1.69"	.313"
16615	BT40 x FMA 1.0" - 1.77"	1.77"	.69"	1.0"	1.18"	2.2"	.375"
16617	BT40 x FMA 1.0" - 3.54"	3.54"	.69"	1.0"	1.18"	2.2"	.375"
16620	BT40 x FMA 1-1/4" - 1.77"	1.77"	.69"	1-1/4"	1.5"	2.75"	.5"
16620-4	BT40 x FMA 1-1/4" - 4"	4"	.69"	1-1/4"	1.5"	2.75"	.5"
16626	BT40 x FMA 1-1/2" - 2.36"	2.36"	.94"	1-1/2"	1.88"	3.8"	.625"

BT50 Face Mill Arbors

Part No.	Description	L	I2	d1	d2	d3	K2
16639	BT50 x 1.0" - 1.77"	1.77"	.79"	1.0"	1.19"	1.97	.375"
16639-3	BT50 x 1.0"- 3"	3"	.79"	1.0"	1.19"	1.97	.375"
16642	BT50 x 1-1/4" - 1.77"	1.77"	.87"	1-1/4"	1.5"	2.34"	.5"
16645	BT50 x 1-1/2" - 1.77"	1.77"	.94"	1-1/2"	1.88"	3.8"	.625"
16646	BT50 x 1-1/2" - 75mm	75mm	.94"	1-1/2"	1.88"	3.8"	.625"
16646-105	BT50 x 1-1/2" - 105mm	105mm	.94"	1-1/2"	1.88"	3.8"	.625"
16646-150	BT50 x 1-1/2" - 150mm	150mm	.94"	1-1/2"	1.88"	3.8"	.625"
16648	BT50 x 2.0" - 2.95"	2.95"	.94"	2"	3.13"	4.88"	.75"



HSK63A and HSK63F Precision Face Mill Arbors



Techniks Certified for accuracy

Features

- Compatible with all face mills
- H6 arbor tolerance for less chatter & better tool life
- Taper ground to AT3 tolerance or better



Arbor
Screws
pg. 128



Tightening
Stands
pg. 234



Retention
Knobs
pg. 228



Wrenches
pg. 232

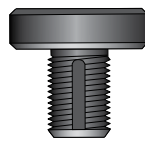

CoolBLAST arbor screw
provides coolant path.
Order on page 128.

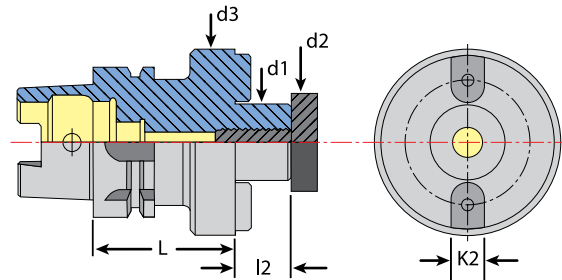

HSK63A Face Mill Arbors Standard and Extended Lengths

Part No.	Description	L	l2	d1	d2	d3	K2
93500	HSK63A x FMA 3/4" - 2"	2"	.687"	.75"	.875"	1.69"	.313"
93510	HSK63A x FMA 3/4" - 4"	4"	.687"	.75"	.875"	1.69"	.313"
NEW 93510-8	HSK63A x FMA 3/4" - 8"	8"	.687"	.75"	.875"	1.69"	.313"
93501	HSK63A x FMA 1.0" - 2.37"	2.37"	.687"	1.0"	1.24"	2.2"	.375"
93520	HSK63A x FMA 1.0" - 4"	4"	.687"	1.0"	1.24"	2.2"	.375"
NEW 93520-6	HSK63A x FMA 1.0" - 6"	6"	.687"	1.0"	1.24"	2.2"	.375"
NEW 93520-8	HSK63A x FMA 1.0" - 8"	8"	.687"	1.0"	1.24"	2.2"	.375"
93502	HSK63A x FMA 1-1/4" - 2.75"	2.75"	.687"	1.25"	1.5"	2.75"	.5"
93530	HSK63A x FMA 1-1/4" - 4"	4"	.687"	1.25"	1.5"	2.75"	.5"
NEW 93530-6	HSK63A x FMA 1-1/4" - 6"	6"	.687"	1.25"	1.5"	2.75"	.5"
NEW 93530-8	HSK63A x FMA 1-1/4" - 8"	8"	.687"	1.25"	1.5"	2.75"	.5"
NEW 93550	HSK63A x FMA 1-1/2" - 4"	4"	.94"	1.5"	1.88"	3.8"	.63"

HSK63F Face Mill Arbors with Drive Keys

Part No.	Description - I.D.	L	l2	d1	d2	d3	K2
NEW 93510-F	HSK63F x FMA 3/4" - 4.0"	4.0"	.69"	3/4"	.88"	1.69"	.31"
NEW 93520-F	HSK63F x FMA 1" - 4.0"	4.0"	.69"	1.0"	1.19"	2.20"	.38"
NEW 93530-F	HSK63F x FMA 1-1/4" - 4.0"	4.0"	.69"	1-1/4"	1.50"	2.75"	.50"
NEW 93550-F	HSK63F x FMA 1-1/2" - 4.0"	4.0"	.94"	1-1/2"	1.88"	3.80"	.63"

HSK100A and R8 Precision Face Mill Arbors



Techniks Certified for accuracy

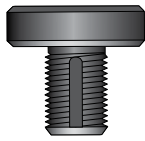

CoolBLAST arbor screw provides coolant path. Order on page 128.

Features

- Compatible with all face mills
- H6 arbor tolerance for less chatter & better tool life
- Taper ground to AT3 tolerance or better



Arbor
Screws
pg. 128



Tightening
Stands
pg. 234



Retention
Knobs
pg. 228



Wrenches
pg. 232

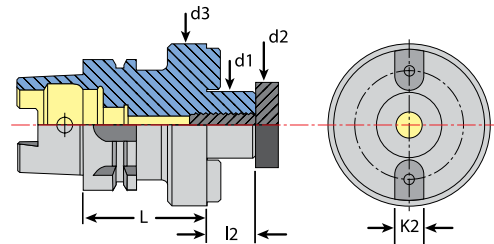

HSK100A Face Mill Arbors

Part No.	Description	L	l2	d1	d2	d3	K2
95901	HSK100A x FMA 3/4" - 2"	2"	.69"	.75"	.88"	1.69"	.31"
NEW 95901-6	HSK100A x FMA 3/4" - 6"	6"	.69"	.75"	.88"	1.69"	.31"
95903	HSK100A x FMA 1.0" - 2"	2"	.69"	1.0"	1.19"	2.2"	.38"
NEW 95903-6	HSK100A x FMA 1.0" - 6"	6"	.69"	1.0"	1.19"	2.2"	.38"
95905	HSK100A x FMA 1-1/4" - 2.5"	2.5"	.69"	1.25"	1.5"	2.75"	.5"
NEW 95905-6	HSK100A x FMA 1-1/4" - 6"	6"	.69"	1.25"	1.5"	2.75"	.5"
95907	HSK100A x FMA 1-1/2" - 2.5"	2.5"	.94"	1.5"	1.88"	3.8"	.63"
NEW 95907-6	HSK100A x FMA 1-1/2" - 6"	6"	.94"	1.5"	1.88"	3.8"	.63"



R8 Face Mill Arbors

Features

- Compatible with all face mills
- H6 arbor tolerance for less chatter & better tool life
- Taper ground to AT3 tolerance or better

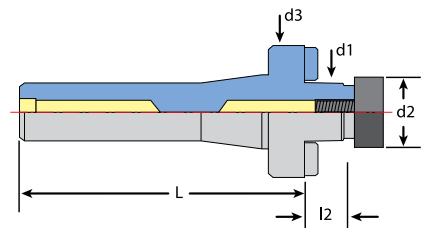

Part No.	Description	L	l2	d1	d2	d3	K2
7582401	R8 x FMA - 0.75	4.7"	.675"	.75"	-	1.93	.37"
7582402	R8 x FMA - 1.0	4.85"	.85"	1.0"	1.24"	1.81"	.37"
7582403	R8 x FMA - 1.25	4.90"	.75"	1.25"	1.62"	2.28"	.47"



CoolBLAST and Standard Face Mill Arbor Screws



CoolBLAST arbor screw provides coolant path.

Features

- Compatible with all face mills
- Works with all Techniks face mill arbors
- For coolant up to 1,500 PSI

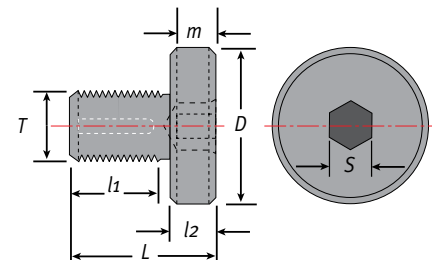

CAT, BT, and HSK CoolBLAST Coolant Arbor Screws

Part No.	Description	Style	Size	D	L	I1	I2	T	S	m
WF.C1-0.5	CoolBLAST arbor screw 1/2"	B	1/2"	5/8"	.84"	.5"	.34"	1/4"-28UNF	3/16"	.157"
WF.C1-0.75	CoolBLAST arbor screw 3/4"	B	3/4"	7/8"	1.8"	1.4"	.37"	3/8"-24UNF	1/4"	.197"
9851125	CAS-A-0.75 smaller "D"	A	3/4"	5/8"	1.375"	1.0"	.36"	3/8"-24UNF	1/4"	.37"
WF.C1-1	CoolBLAST arbor screw 1.0"	B	1.0"	1-3/16"	1.4"	0.81"	.37"	1/2"-20UNF	5/16"	.197"
9851135	CAS-A-1.00 smaller "D"	A	1.0"	3/4"	1.375"	1.0"	.38"	1/2"-20UNF	5/16"	.37"
WF.C1-1.25	CoolBLAST arbor screw 1-1/4"	B	1-1/4"	1-1/2"	1.44"	0.94"	.5"	5/8"-18UNF	5/16"	.236"
WF.C1-1.5	CoolBLAST arbor screw 1-1/2"	B	1-1/2"	1-7/8"	1.63"	1.13"	.5"	3/4"-16UNF	3/8"	.276"
WF.C1-2	CoolBLAST arbor screw 2.0"	B	2"	2-1/2"	1.81"	1.31"	.5"	1.0"-14UNF	1/2"	.354"

Blue indicates coolant.

CAT, BT, and HSK Standard Arbor Screws

Part No.	Description	Arbor Size	D	L	I1	I2	T	S	m
WF0.5	FMA screw 1/2"	1/2"	5/8"	.84"	.5"	.34"	1/4"-28UNF	3/16"	.157"
WF0.75	FMA screw 3/4"	3/4"	7/8"	1.8"	1.4"	.37"	3/8"-24UNF	1/4"	.197"
WF1	FMA screw 1.0"	1.0"	1-3/16"	1.4"	0.81"	.37"	1/2"-20UNF	5/16"	.197"
WF1.25	FMA screw 1-1/4"	1-1/4"	1-1/2"	1.44"	0.94"	.5"	5/8"-18UNF	5/16"	.236"
WF1.5	FMA screw 1-1/2"	1-1/2"	1-7/8"	1.63"	1.13"	.5"	3/4"-16UNF	3/8"	.276"
WF2	FMA screw 2.0"	2"	2-1/2"	1.81"	1.31"	.5"	1.0"-14UNF	1/2"	.354"

Hydros – Milling Chucks – Morse Taper – Drill Chucks

Hydraulic Toolholders

For high-performance PLUS fast tool changes hydro's are a great choice. T.I.R. only 0.0001" at 3XD. Use reduction sleeves to run tool shanks from 1/8" up to 1" (pg. 130)



Milling Chucks

New coolant option available for coolant-thru tools. Outstanding rigidity and performance (pg. 137)



<http://ow.ly/rKwCZ>
View the video.

Morse Taper Holders

Techniks Certified for accuracy (pg.148)



High-Precision Drill Chucks

Better accuracy and holding power than Jacobs Chucks (pg. 146)



Built for Speed.

All Techniks products are backed by our 100% satisfaction guarantee!

NEW

High Precision Hydraulic Toolholders

CAT40, CAT50, BT30, BT40,
HSK63A, HSK100A, HSK63F



Our hydraulic holders extend tool life and improve surface finish because T.I.R. is only 0.0001". Each holder is factory balanced to 25,000 RPM at G2.5.

Extended length hydraulic holders are a great choice for mold work, or any time you need smooth, accurate cutting at extended lengths.

Fast tool changes are performed with just a twist of a wrench (included). You can change tools in-spindle without the need for setup equipment.

Runout Accuracy 0.0001"
T.I.R. measured at 3xD



Precision Reduction Sleeves
Use sleeves for fast tool changes



reduction sleeves fit shank sizes 1/8" up to 5/8" (3 - 16mm) see pg. 6



Use Hydraulic Chucks for:

- face milling and edge milling
- drilling
- reaming
- chamfering

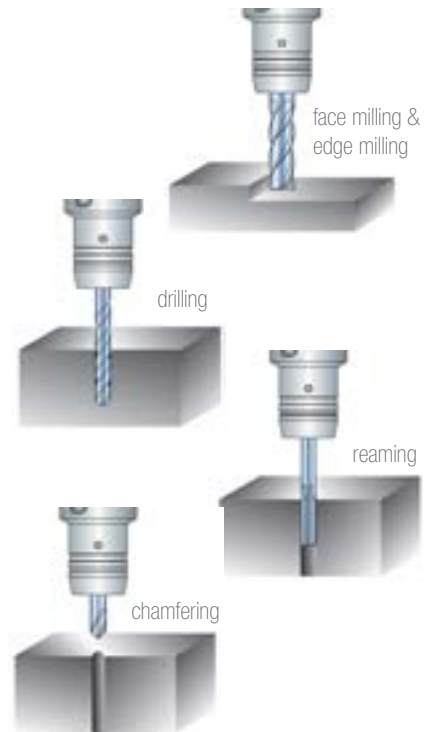

All Techniks products are backed by our 100% satisfaction guarantee!



CAT40 High Precision Hydraulic Toolholders



Features

- Balanced to 25,000 RPM at G2.5
- T.I.R. 0.0001" measured at 3X shank diameter
- Taper precision ground to AT3 standard
- AD/B CoolFLEX coolant standard

Hydraulic Chucks provide powerful, vibration-free cutting. Hydros are a good choice when you need T.I.R. of 0.0001" and high holding power.

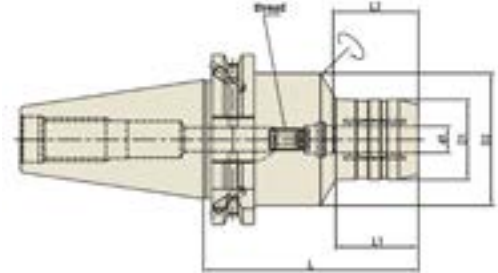

CAT40 Hydraulic Toolholders – Inch and Metric

Part No.	Description	d1	D1	D2	L	L1	L2	Thread
154500	CAT40AD/B-HC 1/2S-2.52 Hydro	1/2"	1.654"	-	2.520"	-	1.457"	M10x1.0
154625	CAT40AD/B-HC 5/8S-2.52 Hydro	5/8"	1.339"	1.772"	2.520"	-	1.654"	M12x1.0
154750	CAT40AD/B-HC 3/4S-2.52 Hydro	3/4"	1.496"	1.969"	2.520"	-	1.654"	M16x1.0
154100	CAT40AD/B- HC 1S-3.50 Hydro	1.0"	2.244"	2.598"	3.504"	-	1.890"	M16x1.0
154060	CAT40AD/B-HC 6-80.5 Hydro	6mm	26mm	50mm	80.5mm	20mm	27mm	M5x0.8
154080	CAT40AD/B-HC 8-80.5 Hydro	8mm	28mm	50mm	80.5mm	30mm	37mm	M12x1.0
154010	CAT40AD/B-HC 10-80.5 Hydro	10mm	30mm	50mm	80.5mm	32mm	32mm	M8x1.0
154012	CAT40AD/B-HC 12-80.5 Hydro	12mm	32mm	50mm	80.5mm	32mm	37mm	M10x1.0
154016	CAT40AD/B-HC 16-80.5 Hydro	16mm	38mm	50mm	80.5mm	33mm	42mm	M12x1.0
154020	CAT40AD/B-HC 20-64.5 Hydro	20mm	37mm	50mm	64.5mm	34mm	42mm	M16x1.0
154200	CAT40AD/B-HC 20-80.5 Hydro	20mm	42mm	50mm	80.5mm	34mm	42mm	M16x1.0



Extended length hydros are a great choice for mould work or wherever high accuracy and smooth cutting is required.

CAT40 Extended Length Hydraulic Toolholders – Inch Size

Part No.	Description	d1	D1	D2	L	L1	L2	Thread
854022	CAT40AD/B-EXT 1/4-4.72 Hydro	1/4"	0.787"	1.969"	4.724"	2.756"	1.063"	M5x0.8
854024	CAT40AD/B-EXT 1/4-5.91 Hydro	1/4"	0.787"	1.969"	5.906"	3.937"	1.063"	M5x0.8
854028	CAT40AD/B-EXT 3/8-4.72 Hydro	3/8"	0.945"	1.969"	4.724"	2.756"	1.260"	M8x1.0
854030	CAT40AD/B-EXT 3/8-5.91 Hydro	3/8"	0.945"	1.969"	5.906"	3.937"	1.260"	M8x1.0
854032	CAT40AD/B-EXT 1/2-4.72 Hydro	1/2"	1.024"	1.969"	4.724"	2.756"	1.457"	M10x1.0
854034	CAT40AD/B-EXT 1/2-5.91 Hydro	1/2"	1.024"	1.969"	5.906"	3.937"	1.457"	M10x1.0
854036	CAT40AD/B-EXT 5/8-4.72 Hydro	5/8"	1.260"	1.969"	4.724"	2.756"	1.654"	M12x1.0
854038	CAT40AD/B-EXT 5/8-5.90 Hydro	5/8"	1.260"	1.969"	5.906"	3.937"	1.654"	M12x1.0
854040	CAT40AD/B-EXT 3/4-4.72 Hydro	3/4"	1.339"	1.969"	4.724"	2.756"	1.654"	M16x1.0
854042	CAT40AD/B-EXT 3/4-5.90 Hydro	3/4"	1.339"	1.969"	5.906"	3.937"	1.654"	M16x1.0

* Note: Wrench included with all toolholders



CAT50 High Precision Hydraulic Toolholders



Features

- *Balanced to 25,000 RPM at G2.5*
- *T.I.R. 0.0001" measured at 3X shank diameter*
- *Taper precision ground to AT3 standard*
- *AD/B CoolFLEX coolant standard*



Retention
Knobs
pg. 228



Wrenches
pg. 232



Tightening
Stands
pg. 234

Hydraulic Chucks provide powerful, vibration-free cutting in all materials. Hydros are a good choice when you need T.I.R. of 0.0001" and high holding power.

Tool changes are fast and easy and can be performed in-spindle. Simply turn the adjusting screw to apply hydraulic clamping on tool shank. Use reduction sleeves to run a variety of shank sizes all from 1/8" up to 5/8".

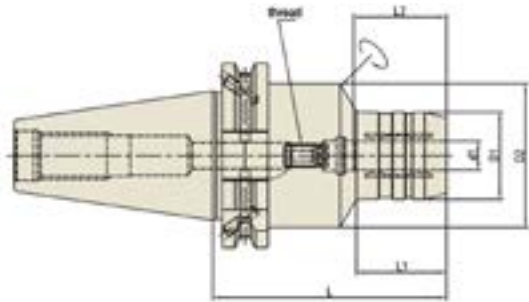

CAT50 Hydraulic Toolholders – Inch and Metric

Part No.	Description	d1	D1	D2	L	L1	L2	Thread
155750	CAT50AD/B-HC 3/4S-3.19 Hydro	3/4"	2.205"	2.756"	3.189"	-	1.654"	M16x1.0
155100	CAT50AD/B-HC 1S-3.19 Hydro	1.0"	2.165"	2.756"	3.189"	-	1.890"	M16x1.0
155125	CAT50AD/B-HC 1.25S-3.19 Hydro	1 1/4"	2.165"	2.756"	3.189"	-	2.165"	M16x1.0
155060	CAT50AD/B-HC 6-80.5 Hydro	6mm	26mm	50mm	80.5mm	30mm	27mm	M5x0.8
155080	CAT50AD/B-HC 8-80.5 Hydro	8mm	28mm	50mm	80.5mm	30mm	27mm	M12x1.0
155010	CAT50AD/B-HC 10-80.5 Hydro	10mm	30mm	50mm	80.5mm	32mm	32mm	M8x1.0
155012	CAT50AD/B-HC 12-80.5 Hydro	12mm	32mm	50mm	80.5mm	35mm	37mm	M10x1.0
155016	CAT50AD/B-HC 16-80.5 Hydro	16mm	38mm	50mm	80.5mm	40mm	42mm	M12x1.0
155200	CAT50AD/B-HC 20-80.5 Hydro	20mm	42mm	50mm	80.5mm	40mm	42mm	M16x1.0

* Note: Wrench included with all toolholders

BT30, BT40 High Precision Hydraulic Holders



Features

- *Balanced to 25,000 RPM at G2.5*
- *T.I.R. 0.0001" measured at 3X shank diameter*
- *Taper precision ground to AT3 standard*
- *AD/B CoolFLEX coolant standard*

Use cutting tools with an H6 shank tolerance.

Hydraulic Chucks provide powerful, vibration-free cutting in all materials. Hydros are a good choice when you need T.I.R. of 0.0001" and high holding power.

Tool changes are fast and easy and can be performed in-spindle. Simply turn the adjusting screw to apply hydraulic clamping on tool shank. Use reduction sleeves to run a variety of shank sizes all from 1/8" up to 5/8".



Retention
Knobs
pg. 228



Wrenches
pg. 232



Tightening
Stands
pg. 234

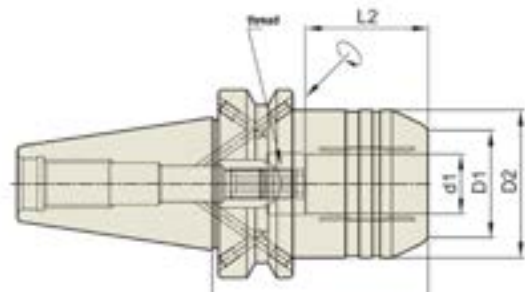

BT30 Hydraulic Toolholders – Inch Size

Part No.	Description	d1	D1	D2	L	L1	L2	Thread
153250	BT30AD/B-HC 1/4-2.75 Hydro	1/4"	1.024"	1.772"	2.756"	1.142"	1.063"	M5x0.8
153312	BT30AD/B-HC 5/16-2.75 Hydro	5/16"	1.102"	1.772"	2.756"	1.181"	1.063"	M6x1.0
153375	BT30AD/B-HC 3/8-2.95 Hydro	3/8"	1.181"	1.772"	2.953"	1.220"	1.260"	M8x1.0
153500	BT30AD/B-HC 1/2-3.35 Hydro	1/2"	1.260"	1.772"	3.346"	1.575"	1.457"	M10x1.0
153675	BT30AD/B-HC 5/8-3.54 Hydro	5/8"	1.496"	1.772"	3.543"	1.811"	1.654"	M6x1.0
153750	BT30AD/B-HC 3/4-3.54 Hydro	3/4"	1.654"	1.772"	3.543"	1.890"	1.654"	M6x1.0

BT40 Hydraulic Toolholders – Inch Size

Part No.	Description	d1	D1	D2	L	L1	L2	Thread
156250	BT40AD/B-HC 1/4-3.54 Hydro	1/4"	1.024"	1.772"	3.543"	1.181"	1.063"	M5x0.8
156312	BT40AD/B-HC 5/16-3.54 Hydro	5/16"	1.102"	1.772"	3.543"	1.299"	1.063"	M6x1.0
156375	BT40AD/B-HC 3/8-3.54 Hydro	3/8"	1.181"	1.772"	3.543"	1.260"	1.260"	M8x1.0
156500	BT40AD/B-HC 1/2-3.54 Hydro	1/2"	1.260"	1.772"	3.543"	1.378"	1.457"	M10x1.0
156625	BT40AD/B-HC 5/8-3.54 Hydro	5/8"	1.496"	1.890"	3.543"	1.575"	1.654"	M12x1.0
156750	BT40AD/B-HC 3/4-3.54 Hydro	3/4"	1.654"	1.890"	3.543"	1.575"	1.654"	M16x1.0
156100	BT40AD/B-HC 1-3.94 Hydro	1.0"	1.969"	2.362"	3.937"	1.772"	1.890"	M16x1.0

* Note: Wrench included with all toolholders



HSK63A High Precision Hydraulic Holders



Features

- Balanced to 25,000 RPM at G2.5
- T.I.R. 0.0001" measured at 3X shank diameter
- Taper precision ground to AT3 standard
- AD coolant-thru is standard

Hydraulic Chucks provide powerful, vibration-free cutting in all materials. Hydros are a good choice when you need T.I.R. of 0.0001" and high holding power. Use cutting tools with a H6 shank tolerance.

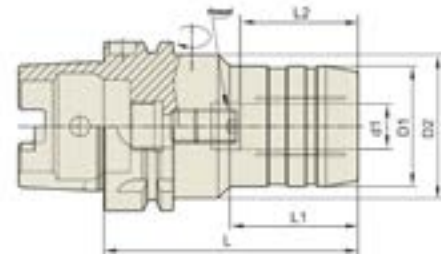

HSK63A Hydraulic Toolholders – Inch and Metric

Part No.	Description	d1	D1	D2	L	L1	L2	Thread
157250	HSK63A-HC 1/4-70 Hydro	1/4"	1.024"	1.969"	2.756"	0.945"	1.063"	M5x0.8
157500	HSK63A-HC 1/2-85 Hydro	1/2"	1.260"	1.969"	3.346"	1.575"	1.457"	M10x1.0
157750	HSK63A-HC 3/4-90 Hydro	3/4"	1.654"	1.969"	3.543"	1.890"	1.654"	M16x1.0
157100	HSK63A-HC 1-4.72 Hydro	1.0"	2.244"	2.480"	4.724"	2.323"	1.890"	M16x1.0
157125	HSK63A-HC 1.1/4-4.92 Hydro	1 1/4"	2.520"	2.953"	4.921"	2.480"	2.165"	M16x1.0
157060	HSK63A-HC 6-70 Hydro	6mm	26mm	50mm	70mm	24mm	27mm	M5x0.8
157080	HSK63A-HC 8-70 Hydro	8mm	28mm	50mm	70mm	25mm	27mm	M6x1.0
157010	HSK63A-HC 10-80 Hydro	10mm	30mm	50mm	80mm	35mm	32mm	M8x1.0
157012	HSK63A-HC 12-85 Hydro	12mm	32mm	50mm	85mm	-	37mm	M10x1.0
157014	HSK63A-HC 14-85 Hydro	14mm	34mm	50mm	85mm	40mm	37mm	M10x1.0
157016	HSK63A-HC 16-90 Hydro	16mm	38mm	50mm	90mm	46mm	42mm	M12x1.0
157018	HSK63A-HC 18-90 Hydro	18mm	40mm	50mm	90mm	47mm	42mm	M12x1.0
157200	HSK63A-HC 20-80 Hydro	20mm	53mm	53mm	80mm	-	42mm	M16x1.0
157020	HSK63A-HC 20-90 Hydro	20mm	42mm	50mm	90mm	48mm	42mm	M16x1.0
157025	HSK63A-HC 25-120 Hydro	25mm	57mm	63mm	120mm	54.5mm	48mm	M16x1.0
157032	HSK63A-HC 32-125 Hydro	32mm	64mm	75mm	125mm	63mm	55mm	M16x1.0

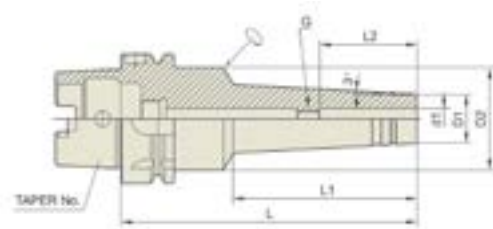

HSK63A-HMC Hydraulic Toolholders – Inch

Part No.	Description	d1	D1	D2	L	L1	L2	Thread
158250	HSK63A-HMC 1/4"-5.71 Hydro	1/4"	0.787"	1.969"	5.709"	3.543"	1.063"	M5x0.8
158312	HSK63A-HMC 5/16"-5.71 Hydro	5/16"	0.866"	1.969"	5.709"	3.543"	1.063"	M6x1.0
158375	HSK63A-HMC 3/8"-5.71 Hydro	3/8"	0.945"	1.969"	5.709"	3.543"	1.260"	M8x1.0
158500	HSK63A-HMC 1/2"-5.71 Hydro	1/2"	1.024"	1.969"	5.709"	3.543"	1.457"	M10x1.0
158625	HSK63A-HMC 5/8"-5.7 Hydro	5/8"	1.260"	1.969"	5.709"	3.543"	1.654"	M12x1.0
158750	HSK63A-HMC 3/4"-5.7 Hydro	3/4"	1.339"	1.969"	5.709"	3.543"	1.654"	M16x1.0

HSK63F, HSK100A High Precision Hydraulic Holders



Features

- *Balanced to 25,000 RPM at G2.5*
- *T.I.R. 0.0001" measured at 3X shank diameter*
- *Taper precision ground to AT3 standard*
- *AD coolant-thru is standard*

Hydraulic Chucks provide powerful, vibration-free cutting in all materials. Hydros are a good choice when you need T.I.R. of 0.0001" and high holding power. Use cutting tools with a H6 shank tolerance.

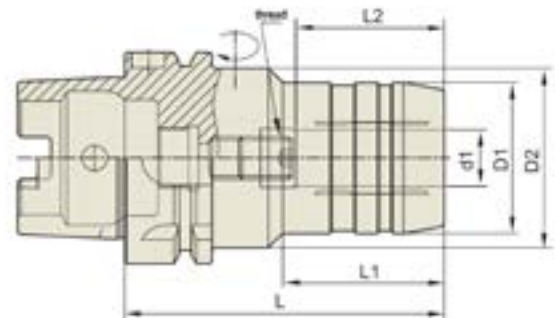

HSK63F Hydraulic Toolholders – Inch Size

Part No.	Description	d1	D1	D2	L	L1	L2	Thread
160750	HSK63F-HC 3/4-85 Hydro	3/4"	1.654"	1.969"	3.346"	1.693"	1.654"	M16x1.0
160100	HSK63F-HC 1-120 Hydro	1.0"	2.244"	2.480"	4.724"	2.323"	1.575"	M16x1.0

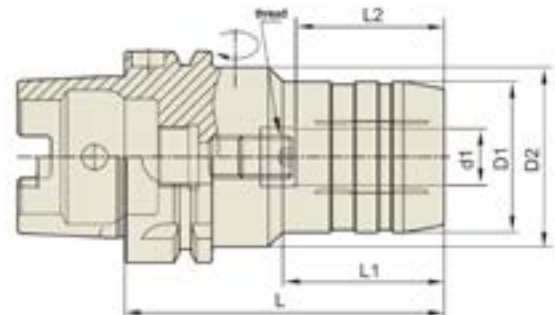

HSK100A Hydraulic Toolholders – Inch and Metric

Part No.	Description	d1	D1	D2	L	L1	L2	Thread
159250	HSK100A-HC 1/4-75 Hydro	1/4"	1.024"	1.969"	2.953"	1.024"	1.063"	M5x0.8
159375	HSK100A-HC 3/8-90 Hydro	3/8"	1.181"	1.969"	3.543"	1.654"	1.260"	M8x1.0
159500	HSK100A-HC 1/2-95 Hydro	1/2"	1.260"	1.969"	3.740"	1.850"	1.457"	M10x1.0
159750	HSK100A-HC 3/4-105 Hydro	3/4"	1.654"	4.134"	2.323"	1.654"	1.654"	M16x1.0
159100	HSK100A-HC 1-110 Hydro	1.0"	2.244"	2.480"	4.331"	2.441"	1.890"	M16x1.0
159125	HSK100A-HC 31 1/4-110 Hydro	1 1/4"	2.520"	2.953"	4.331"	2.441"	2.165"	M16x1.0
159200	HSK100A-HC 20S-90 Hydro	20mm	53mm	53mm	90mm	-	42mm	M16x1.0

High Precision Reduction Sleeves



Features

- Made from high-grade tool steel
- Precision ground accuracy
- Fits tools 1/8" up to 5/8" (3-20mm)

20mm O.D. – Metric or Inch I.D. Sleeves

Part No.	Description, O.D. - I.D.
820030	20-03 reduction sleeve
820040	20-04 reduction sleeve
820050	20-05 reduction sleeve
820060	20-06 reduction sleeve
820080	20-08 reduction sleeve
820100	20-10 reduction sleeve
820120	20-12 reduction sleeve
820140	20-14 reduction sleeve
820160	20-16 reduction sleeve
520108	20-1/8" reduction sleeve
520316	20-3/16" reduction sleeve
520104	20-1/4" reduction sleeve
520516	20-5/16" reduction sleeve
520308	20-3/8" reduction sleeve
520102	20-1/2" reduction sleeve
520508	20-5/8" reduction sleeve

The slots in these high-precision sleeves are cut using ultra-precision sawing technology, ensuring the most accurate I.D. possible, and providing strong clamping force.

Assemble the cutting tool into the sleeve first, then insert the assembly into the hydraulic toolholder. Do not load sleeve and collet separately. Turn the clamping screw clockwise to apply clamping pressure.

NOTE: Do not turn clamping screw unless there is a sleeve or cutting tool in the toolholder, or damage may occur.

3/4" O.D. – Inch Size I.D. Sleeves

Part No.	Description, O.D. - I.D.
625108	3/4-1/8" reduction sleeve
625316	3/4-3/16" reduction sleeve
625104	3/4-1/4" reduction sleeve
625516	3/4-5/16" reduction sleeve
625308	3/4-3/8" reduction sleeve
625102	3/4-1/2" reduction sleeve
625508	3/4-5/8" reduction sleeve

1-1/4" O.D. – Inch I.D. Sleeves

Part No.	Description, O.D. - I.D.
632108	1-1/4-1/8" reduction sleeve
632316	1-1/4-3/16" reduction sleeve
632104	1-1/4-1/4" reduction Sleeve
632516	1-1/4-5/16" reduction sleeve
632308	1-1/4-3/8" reduction sleeve
632102	1-1/4-1/2" reduction sleeve
632508	1-1/4-5/8" reduction sleeve
632304	1-1/4-3/4" reduction sleeve
632508	1-1/4-1.0" reduction sleeve

CAT40, CAT50 High-Performance Milling Chucks



3/4" chuck shown above. Use milling chuck sleeves (page 140) to change tool shank size.



Each Techniks High-Performance Milling Chuck is inspected, tested, and certified for quality, accuracy, and holding power. A full lab report is included with each holder.

Features

- Grips shank up to 5x tighter than ER 40 holders
- Nut seats against the flange when properly tightened (prevents overtightening)
- CoolBLAST coolant-thru standard on all milling chucks

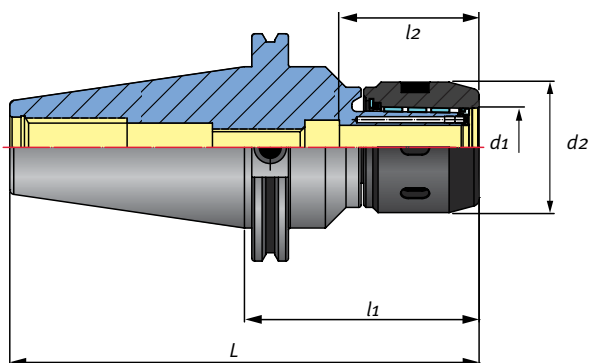

CAT40 Milling Chucks

Part No.	Description	L	l1	l2	d1	d2	Holding Power
23202G	CAT40 x MLD 3/4" - 4"	6.69"	4.0"	2.38"	0.75"	2.24"	350 ft/lbs
23204G	CAT40 x MLD 1" - 4"	6.69"	4.0"	2.23"	1.0"	2.36"	425 ft/lbs
23210G	CAT40 x MLD 1-1/4" - 4.2"	6.89"	4.2"	2.38"	1.25"	2.80"	500 ft/lbs

CAT50 Milling Chucks

Part No.	Description	L	l1	l2	d1	d2	Holding Power
23214G	CAT50 x MLD 3/4" - 4"	8.0"	4.0"	2.38"	0.75"	2.24"	350 ft/lbs
23218G	CAT50 x MLD 1" - 4"	8.0"	4.0"	2.23"	1.0"	2.36"	425 ft/lbs
23222G	CAT50 x MLD 1-1/4" - 4.13"	8.13"	4.13"	2.38"	1.25"	2.80"	500 ft/lbs

Standard Features for Techniks Milling Chucks

CoolBLAST Coolant-Thru



Coolant is channeled directly onto tool path.

Special Slotted Design



Special slotted design of bore I.D. increases holding power and reduces vibration.

Machined Bearing Cage

High-precision, individually matched needle bearings symmetrically placed for smooth and reliable operation.

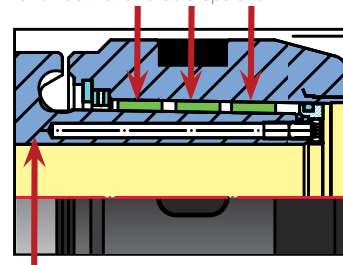

Machined bearing cage ensures accuracy and gripping force.

CAT40, 50 DualDRIVE for Dual-Contact Spindles



3/4" chuck shown with optional coolant cap and Black Gold coolant ring.

Features

- Techniks Certified for dual-contact spindles
- Grips shank up to 5x tighter than ER 40 holders
- Nut seats against the flange when properly tightened (prevents overtightening)



See an on machine demonstration video of DualDRIVE compared to standard toolholders at: <http://ow.ly/sUOqL>

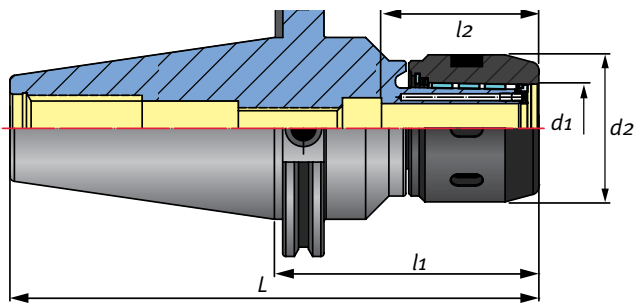

Torque Tested to 5x Tighter Grip

Techniks Milling Chucks provide up to 5x tighter grip on the shank than other manufacturer's ER 40 holders with an uncoated nut.

Toolholder Type	Shank Spins At:
Other ER 40 holders	100 ft/lbs
Techniks 3/4" milling chucks	350 ft/lbs
Techniks 1" milling chucks	425 ft/lbs
Techniks 1-1/4" milling chucks	500 ft/lbs

CAT40, CAT50 Milling Chucks with DualDRIVE

Part No.	Description	L	l1	l2	d1	d2	Holding Power
43.463G.64.400	CAT40 x MLD 3/4" - 4" DualDRIVE	6.69"	4.00"	2.38"	0.75"	2.24"	350 ft/lbs
43.463G.68.400	CAT40 x MLD 1" - 4" DualDRIVE	6.69"	4.0"	2.23"	1.0"	2.36"	425 ft/lbs
43.463G.72.420	CAT40 x MLD 1-1/4" - 4.2" DualDRIVE	6.89"	4.20"	2.38"	1.25"	2.80"	500 ft/lbs
44.463G.64.400	CAT50 x MLD 3/4" - 4" DualDRIVE	8.00"	4.00"	2.38"	0.75"	2.24"	350 ft/lbs
44.463G.68.400	CAT50 x MLD 1" - 4" DualDrive	8.0"	4.0"	2.23"	1.0"	2.36"	425 ft/lbs
44.463G.72.413	CAT50 x MLD 1-1/4" - 4.13" DualDRIVE	8.13"	4.13"	2.38"	1.25"	2.80"	500 ft/lbs

Coolant Cap option for all spindle types

Use coolant cap and Black Gold ring for coolant-thru tools.

- Maximum chip removal, increase feed rates, extend tool life



Insert Black Gold coolant ring into cap



Cap screws onto end of milling chuck



Coolant-thru tool installed



Use coolant cap with Black Gold ER25 or ER40 coolant rings. Select the coolant ring to fit your shank size. See page 60

Part No.	Description	Ring
19496G	For 3/4" chuck	ER25
19489G	For 1-1/4" chuck	ER40

BT40, HSK63A, and HSK100A Milling Chucks



1-1/4" chuck shown above. Use milling chuck sleeves (page 140) to change tool shank size.



Each Techniks High-Performance Milling Chuck is inspected, tested, and certified for quality, accuracy, and holding power. A full lab report is included with each holder.

Features

- Grips shank up to 5x tighter than ER 40 holders
- Nut seats against the flange when properly tightened (prevents overtightening)
- CoolBLAST coolant-thru standard on all milling chucks

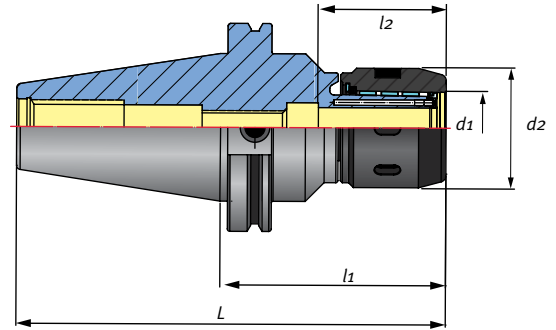

BT40 Milling Chucks

Part No.	Description	L	l1	l2	d1	d2	Holding Power
15994G	BT40 X MLD 3/4" - 3.15	5.75"	3.15"	1.97"	0.75"	2.22"	350 ft/lbs
15995G	BT40 X MLD 1" - 3.15	5.75"	3.15"	2.07"	1.0"	2.36"	425 ft/lbs
15996G	BT40 x MLD 1-1/4" - 4"	6.57"	4"	2.62"	1.25"	2.80"	500 ft/lbs



3/4" chuck shown above. Use milling chuck sleeves (page 123) to change tool shank size.



Tightening
Stands
pg. 234



Retention
Knobs
pg. 228



Wrenches
pg. 232

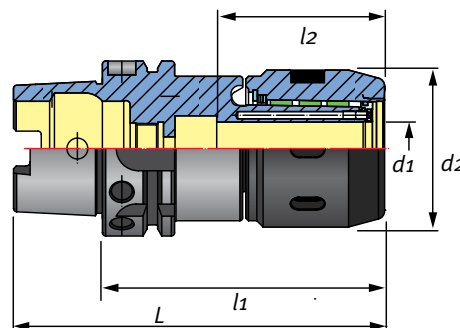

For coolant-thru tools order the coolant ring that fits your shank size (pg. 138)



HSK63A and HSK100A Milling Chucks

Part No.	Description	L	l1	l2	d1	d2	Holding Power
33232G	HSK63A X MLD 3/4" - 4"	5.30"	4"	2.01"	.75"	2.22"	350 ft/lbs
33236G	HSK63A x MLD 1-1/4" - 4.72"	5.98"	4.72"	2.65"	1.25"	2.80"	500 ft/lbs
33252G	HSK100A X MLD 3/4" - 4.72"	6.70"	4.72"	2.01"	.75"	2.22"	350 ft/lbs
33256G	HSK100A x MLD 1-1/4" - 4.72"	6.70"	4.72"	2.65"	1.25"	2.79"	500 ft/lbs



Precision Reduction Sleeves for Milling Chucks



Use sleeves to change tool shank sizes just like you would collets.

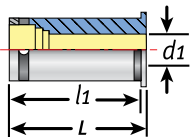

Milling Chuck Reduction Sleeves

- For inch and metric shanks
- T.I.R only .0001"
- Precision ground for maximum accuracy
- Maximize your milling chuck capability

3/4" O.D. Reduction Sleeves for 3/4" Chucks

Part No.	Description	d1	l1	L
84126-1/8	3/4" O.D., x 1/8" I.D.	1/8"	1.93"	2.09"
84126-3/16	3/4" O.D., x 3/16" I.D.	3/16"	1.93"	2.09"
84126-1/4	3/4" O.D., x 1/4" I.D.	1/4"	1.93"	2.09"
84126-5/16	3/4" O.D., x 5/16" I.D.	5/16"	1.93"	2.09"
84126-3/8	3/4" O.D., x 3/8" I.D.	3/8"	1.93"	2.09"
84126-7/16	3/4" O.D., x 7/16" I.D.	7/16"	1.93"	2.09"
84126-1/2	3/4" O.D., x 1/2" I.D.	1/2"	1.93"	2.09"
84126-9/16	3/4" O.D., x 9/16" I.D.	9/16"	1.93"	2.09"
84126-5/8	3/4" O.D., x 5/8" I.D.	5/8"	1.93"	2.09"
84126-06	3/4" O.D., x 6mm I.D.	6mm	1.93"	2.09"
84126-08	3/4" O.D., x 8mm I.D.	8mm	1.93"	2.09"
84126-10	3/4" O.D., x 10mm I.D.	10mm	1.93"	2.09"
84126-12	3/4" O.D., x 12mm I.D.	12mm	1.93"	2.09"

1" O.D. Reduction Sleeves for 1" Chucks

Part No.	Description	d1	l1	L
84128-1/2	SSC 1" - 1/2" I.D.	1/2"	2.16"	2.36"
84128-1/4	SSC 1" - 1/4" I.D.	1/4"	2.16"	2.36"
84128-1/8	SSC 1" - 1/8" I.D.	1/8"	2.16"	2.36"
84128-3/16	SSC 1" - 3/16" I.D.	3/16"	2.16"	2.36"
84128-3/4	SSC 1" - 3/4" I.D.	3/4"	2.16"	2.36"
84128-3/8	SSC 1" - 3/8" I.D.	3/8"	2.16"	2.36"
84128-5/16	SSC 1" - 5/16" I.D.	5/16"	2.16"	2.36"
84128-5/8	SSC 1" - 5/8" I.D.	5/8"	2.16"	2.36"
84128-7/16	SSC 1" - 7/16" I.D.	7/16"	2.16"	2.36"
84128-7/8	SSC 1" - 7/8" I.D.	7/8"	2.16"	2.36"
84128-9/16	SSC 1" - 9/16" I.D.	9/16"	2.16"	2.36"

Special slotted design (right) of bore I.D. increases holding power and reduces vibration.

Insert sleeve into chuck, then insert cutting tool, and tighten chuck last.



1-1/4" O.D. Reduction Sleeves for 1-1/4" Chucks

Part No.	Description	d1	l1	L
84127-1/8	1-1/4" O.D., x 1/8" I.D.	1/8"	2.56"	2.75"
84127-3/16	1-1/4" O.D., x 3/16" I.D.	3/16"	2.56"	2.75"
84127-1/4	1-1/4" O.D., x 1/4" I.D.	1/4"	2.56"	2.75"
84127-5/16	1-1/4" O.D., x 5/16" I.D.	5/16"	2.56"	2.75"
84127-3/8	1-1/4" O.D., x 3/8" I.D.	3/8"	2.56"	2.75"
84127-7/16	1-1/4" O.D., x 7/16" I.D.	7/16"	2.56"	2.75"
84127-1/2	1-1/4" O.D., x 1/2" I.D.	1/2"	2.56"	2.75"
84127-9/16	1-1/4" O.D., x 9/16" I.D.	9/16"	2.56"	2.75"
84127-5/8	1-1/4" O.D., x 5/8" I.D.	5/8"	2.56"	2.75"
84127-3/4	1-1/4" O.D., x 3/4" I.D.	3/4"	2.56"	2.75"
84127-7/8	1-1/4" O.D., x 7/8" I.D.	7/8"	2.56"	2.75"
84127-1	1-1/4" O.D., x 1.0" I.D.	1.0"	2.56"	2.75"
84127-08	1-1/4" O.D., x 8mm I.D.	8mm	2.56"	2.75"
84127-10	1-1/4" O.D., x 10mm I.D.	10mm	2.56"	2.75"
84127-12	1-1/4" O.D., x 12mm I.D.	12mm	2.56"	2.75"
84127-14	1-1/4" O.D., x 14mm I.D.	14mm	2.56"	2.75"
84127-16	1-1/4" O.D., x 16mm I.D.	16mm	2.56"	2.75"
84127-20	1-1/4" O.D., x 20mm I.D.	20mm	2.56"	2.75"
84127-25	1-1/4" O.D., x 25mm I.D.	25mm	2.56"	2.75"

Precision CAT and HSK Tool Blanks for Machining



Techniks Certified Features

- Taper ground to AT3 accuracy or better
- Each blank is individually tested, measured and certified for accuracy

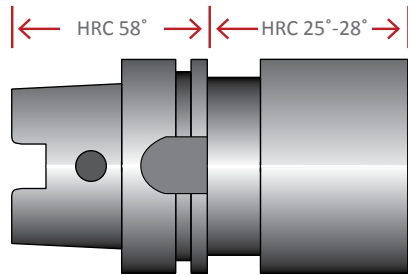

Machinable Blanks

Techniks machinable blanks provide a quality platform for creating your own custom tools. They are made from high-grade tool steel for best performance.

Material analysis shows that the hardness at the spindle end is HRC 58° for long life and reduced spindle wear. The hardness on the machining end is HRC 25°-28° and remains stable from the surface all the way to the core.

CAT and HSK Machinable Blanks

Part No.	Description	Dia.	L1
31.001.92.600	CAT40 x 2.5"-6	2.5"	6"
31.001.92.100	CAT40 x 2.5"-10	2.5"	10"
31.001.98.800	CAT50 x 3"-8	3"	8"
31.001.A2.110	CAT50 x 3.5"-11	3.5"	11"
73.001.98.600	HSK63A x 3"-6	3"	6"
73.001.A2.100	HSK63A x 3.5"-10	3.5"	10"
75.001.A2.100	HSK100A x 3.5"-10	3.5"	10"

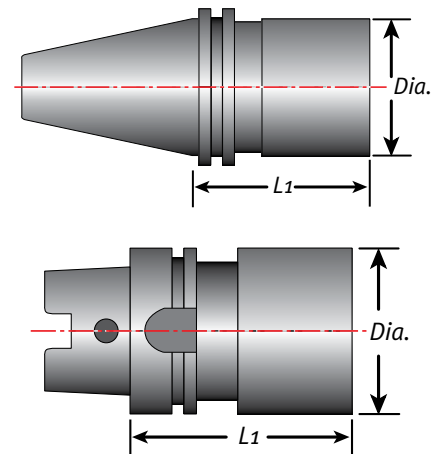

Precision CAT and BT Morse Taper Toolholders



Techniks Certified Tooling Features

- Taper ground to AT3 accuracy or better
- .0002" runout from taper to tool pocket
- Each holder lab certified for accuracy



Tightening
Stands
pg. 234

Retention
Knobs
pg. 228

Wrenches
pg. 232

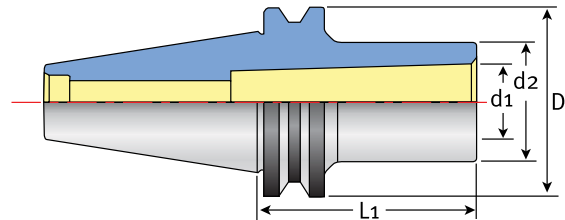

CAT40, CAT50 Morse Taper Toolholders

Part No.	Taper	Size	L1	d1	d2	D
22611	CAT40 Morse Taper	MT#1	1.75"	.475"	.984"	2.5"
22613	CAT40 Morse Taper	MT#2	2.00"	.7"	1.26"	2.5"
22615	CAT40 Morse Taper	MT#3	2.75"	.937"	1.575"	2.5"
22617	CAT40 Morse Taper	MT#4	3.75"	1.231"	1.889"	2.5"

CAT50 Morse Taper Toolholders

Part No.	Taper	Size	L1	d1	d2	D
22623	CAT50 Morse Taper	MT#2	2.00"	.7"	1.26"	3.875"
22625	CAT50 Morse Taper	MT#3	2.56"	.937"	1.575"	3.875"
22627	CAT50 Morse Taper	MT#4	3.75"	1.231"	1.889"	3.875"
22629	CAT50 Morse Taper	MT#5	4.13"	1.75"	2.48"	3.875"

Precision BT30, BT40, BT50 Morse Taper Toolholders



Techniks Certified Tooling Features

- Taper ground to AT3 accuracy or better
- .0002" runout from taper to tool pocket
- Each holder lab certified for accuracy

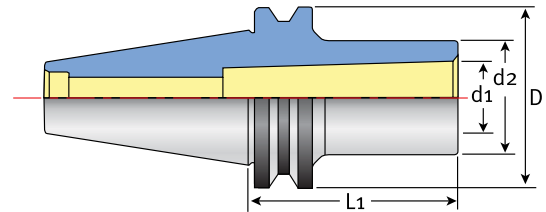

BT30, BT40, BT50 Morse Taper Toolholders

Part No.	Taper	Size	L1	d1	d2	D
17001	BT30 Morse Taper	MT#1	1.77"	.475"	.984"	1.811"
17006	BT30 Morse Taper	MT#2	2.36"	.7"	1.26"	1.811"
17010	BT30 Morse Taper	MT#3	3.14"	.937"	1.575"	1.811"

BT40 Morse Taper Toolholders

Part No.	Taper	Size	L1	d1	d2	D
17011	BT40 Morse Taper	MT#1	1.77"	.475"	.984"	2.48"
17014	BT40 Morse Taper	MT#2	1.96"	.7"	1.26"	2.48"
17018	BT40 Morse Taper	MT#3	2.75"	.937"	1.575"	2.48"
17023	BT40 Morse Taper	MT#4	3.75"	1.231"	1.889"	2.48"

BT50 Morse Taper Toolholders

Part No.	Taper	Size	L1	d1	d2	D
17036	BT50 Morse Taper	MT#2	2.36"	.7"	1.26"	3.937"
17039	BT50 Morse Taper	MT#2-135	5.31"	.7"	1.26"	3.937"
17042	BT50 Morse Taper	MT#3	2.56"	.937"	1.575"	3.937"
17046	BT50 Morse Taper	MT3-150	5.9"	.937"	1.575"	3.937"
17048	BT50 Morse Taper	MT#4	3.74"	1.231"	1.889"	3.937"
17051	BT50 Morse Taper	MT4-180	7.08"	1.231"	1.889"	3.937"
17053	BT50 Morse Taper	MT#5	4.13"	1.75"	2.48"	3.937"

CAT40 and CAT50 SIMIS ER Collet Chucks



Comparison of SIMIS Economy Collet Chucks & Techniks

	SIMIS	Techniks Certified
Lab Certified for Accuracy & Balance	NO	YES
Balance Specification	YES - uncoated	YES - PowerCOAT
DIN B Coolant Available	18,000 RPMs	25,000 RPMs
End Mill Bore Tolerance	NO	YES
Available Sizes	most common	wide selection

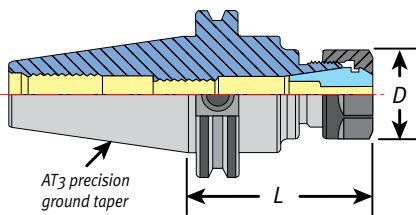

ER Nut Included

Part No.	Description
11116	ER16 uncoated hex nut
11120	ER20 uncoated hex nut
11125	ER25 uncoated slotted nut
11132	ER32 uncoated slotted nut
11140	ER40 uncoated slotted nut



CAT40 ER Toolholders

Part No.	Description	L	D	Collet	Max. Shank	Stop Screw	Wrench
CAT40ER11-3	CAT40 x ER11-3"	3	.748"	ER11	.275"	06081	04608
CAT40ER11-4	CAT40 x ER11-4"	4	.748	ER11	.275"	06081	04608
CAT40ER11-6	CAT40 x ER11-6"	6	.748	ER11	.275"	06081	04608
CAT40ER16-2.76	CAT40 x ER16-2.76"	2.76"	1.08"	ER16	.406"	06083	04609 hex
CAT40ER16-4	CAT40 x ER16-4"	4"	1.08"	ER16	.406"	06083	04609 hex
CAT40ER20-2.76	CAT40 x ER20-2.76"	2.76"	1.34"	ER20	.512"	06087	04610 hex
CAT40ER20-4	CAT40 x ER20-4"	4"	1.34"	ER20	.512"	06087	04610 hex
CAT40ER20-6	CAT40 x ER20-6"	6"	1.34"	ER20	.512"	06087	04610 hex
CAT40ER25-2.76	CAT40 x ER25-2.76"	2.76"	1.65"	ER25	.63"	06089	04615
CAT40ER25-4	CAT40 x ER25-4"	4"	1.65"	ER25	.63"	06089	04615
CAT40ER32-2.76	CAT40 x ER32-2.76"	2.76"	1.97"	ER32	.788"	06089	04616
CAT40ER32-4	CAT40 x ER32-4"	4"	1.97"	ER32	.788"	06089	04616
CAT40ER40-3.15	CAT40 x ER40-3.15"	3.15"	2.48"	ER40	1.023"	06091	04617

CAT50 ER Toolholders

Part No.	Description	L	D	Collet	Max. Shank	Stop Screw	Wrench
CAT50ER16-4	CAT50 x ER16-4	4"	1.08"	ER16	.406"	06083	04609 hex
CAT50ER16-6	CAT50 x ER16-6	6"	1.08"	ER16	.406"	06083	04609 hex
CAT50ER20-4	CAT50 x ER20-4	4"	1.34"	ER20	.512"	06087	04610 hex
CAT50ER20-6	CAT50 x ER20-6	6"	1.34"	ER20	.512"	06087	04610 hex
CAT50ER32-4	CAT50 x ER32-4	4"	1.97"	ER32	.788"	06089	04616
CAT50ER32-6	CAT50 x ER32-6	6"	1.97"	ER32	.788"	06089	04616
CAT50ER40-4	CAT50 x ER40-4	4"	2.48"	ER40	1.023"	06091	04617

CAT40 and CAT50 SIMIS End Mill Holders



SIMIS Economy End Mill Holders vs. Techniks

	SIMIS	Techniks Certified
Lab Certified for Accuracy & Balance	NO	YES
Balance Specification	8,000 RPMs	10,000 RPMs
DIN B Coolant Available	NO	YES
End Mill Bore Tolerance	H7	H5
Available Sizes	most common	wide selection



Tightening
Stands
pg. 234



Retention
Knobs
pg. 228



Wrenches
pg. 232

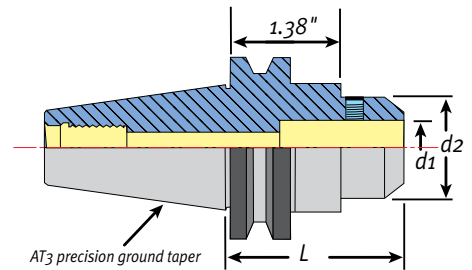

CAT40 End Mill Holders

Part No.	Description – d1	L	d2
CAT40SLN1/8	CAT40 x SLN - 1/8"	2.375"	.69"
CAT40SLN3/16	CAT40 x SLN - 3/16"	2.5"	.69"
CAT40SLN1/4	CAT40 x SLN - 1/4"	3"	.78"
CAT40SLN1/4-1.75	CAT40 x SLN - 1/4"	1.75"	.795"
CAT40SLN3/8	CAT40 x SLN - 3/8"	3"	.88"
CAT40SLN3/8-1.75	CAT40 x SLN - 3/8"	1.75"	.88"
CAT40SLN1/2	CAT40 x SLN - 1/2"	3"	1.25"
CAT40SLN1/2-1.75	CAT40 x SLN - 1/2"	1.75"	1.5"
CAT40SLN5/8	CAT40 x SLN - 5/8"	3"	1.5"
CAT40SLN3/4	CAT40 x SLN - 3/4"	3.5"	1.75"
CAT40SLN3/4-1.75	CAT40 x SLN - 3/4"	1.75"	1.75"
CAT40SLN1	CAT40 x SLN - 1.0"	4"	2"
CAT40SLN1-1.75	CAT40 x SLN - 1.0"	1.75"	1.75"
CAT40SLN1 1/4-2	CAT40 x SLN - 1-1/4"	2"	1.75"

CAT50 End Mill Holders

Part No.	Description – d1	d2	L
CAT50SLN1/4	CAT50 x SLN - 1/4"	.78	4"
CAT50SLN3/8	CAT50 x SLN - 3/8"	1.0"	4"
CAT50SLN1/2	CAT50 x SLN - 1/2"	1.25"	4"
CAT50SLN5/8	CAT50 x SLN - 5/8"	1.5"	4"
CAT50SLN3/4	CAT50 x SLN - 3/4"	1.75"	4"
CAT50SLN1	CAT50 x SLN - 1.0"	2"	4"
CAT50SLN11/4	CAT50 x SLN - 1-1/4"	2.5"	4.6"

HP3 High Precision and Keyless Jacobs Drill Chucks



Features

- Capacity from 1/16" to 1/2"
- 4 times greater holding power
- Balanced to 10,000 RPM

Our HP3 High-Precision Drill Chucks have the flexibility to hold a wide range of shank sizes and deliver superior performance too. Maximum runout (T.I.R.) is only .0008".

They also feature a one-piece design that provides greater rigidity and safety because the chuck cannot break free during operation.

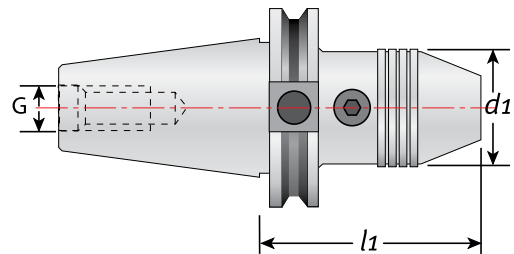

HP3 Precision Drill Toolholders (ISO, BT, HSK)

Part No.	Description	d1	l1	G
24.05.046.005	CAT40 HP3 drill chuck 1/2"	50	103	-
17.05.046.005	CAT50 HP3 drill chuck 1/2"	50	87.5	-
64.05.046.051	ISO30 HP3 drill chuck 1/2"	50	103	M12
67.05.046.001	BT30 HP3 drill chuck 1/2"	50	92.5	M12
39.05.046.001	BT40 HP3 drill chuck 1/2"	50	95.5	M16
93.05.046.003	HSK 63A HP3 drill chuck 1/2"	50	123.5	-
171.05.046.003	HSK63F HP3 drill chuck 1/2"	50	123.5	-



Features

- For milling machines & drilling machines
- All hardened parts for long life and safety
- Use with CAT or BT holders

Keyless Jacobs Taper Drill Chucks

Part No.	Description	Length Closed	Outer Diameter	Range
82150	08S x JT1	76mm	38mm	0 - 5/16"
82153	13S x JT6	102mm	49mm	0 - 1/2"
82151-JT33	10S x JT33	92mm	43mm	0 - 3/8"
82153-JT33	13S x JT33	102mm	49mm	0 - 1/2"

CAT, BT, HSK Replaceable Keyless Drill Chucks



Features

- 3 times more holding power than other chucks
- Holds non-standard shank sizes up to 1/2"
- Replaceable chuck is held by a drawbolt

Order Part No. 82164 replaceable chuck

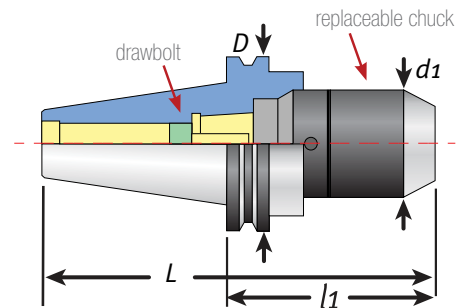

CAT Replaceable Drill Chucks

Part No.	Description	l1	L	D	d1
22403	CAT40 SPU x 1/2" - 4"	101.6mm	169.9mm	63.5mm	50mm
22405	CAT50 SPU x 1/2" - 4"	101.6mm	203.2mm	98.4mm	50mm
82164	SPU drill chuck (replacement)				
82172	SPU drill chuck wrench (replacement)				

BT Replaceable Drill Chucks

Part No.	Description	l1	L	D	d1
16456-W	BT30 x SPU 13mm - 110mm (no slots)	110mm	170.4mm	46mm	50mm
16456	BT30 x SPU 13mm - 110mm	110mm	170.4mm	46mm	50mm
16466	BT40 x SPU 13mm - 100mm	100mm	177.4mm	63mm	50mm
16476	BT50 x SPU 13mm - 100mm	100mm	213.8mm	100mm	50mm
82164	SPU drill chuck (replacement)				
82172	SPU drill chuck wrench (replacement)				

HSK Replaceable Drill Chucks

Part No.	Description	l1	L	D	d1
34905	HSK 63A x SPU 13mm - 150mm	150mm	182.5mm	63mm	50mm
34905-F	HSK 63F x SPU 13mm - 150mm	150mm	175mm	63mm	50mm
82164	SPU drill chuck (replacement)				
82172	SPU drill chuck wrench (replacement)				

CAT and BT Toolholders For Jacobs Taper Drill Chucks



Features

- Better T.I.R. and rigidity than standard drill chucks
- Taper ground to AT3 accuracy
- Use with keyless Jacobs chucks

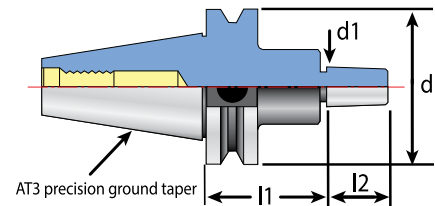

CAT Toolholders For Jacobs Taper Drill Chucks

Part No.	Description	l1	l2	d1	Jacobs Taper
22511	CAT40 x JT2 - 1.57"	1.57"	.875"	.559"	2
22512	CAT40 x JT3 - 1.57"	1.57"	1.2"	.811"	3
22513	CAT40 x JT6 - 1.57"	1.57"	.945"	.676"	6
22515	CAT40 x JT33 - 1.57"	1.57"	.945"	.624"	33
22521	CAT50 x JT2 - 1.57"	1.57"	.875"	.559"	2
22527	CAT50 x JT3 - 1.57"	1.57"	1.2"	.811"	3
22529	CAT50 x JT4 - 1.57"	1.57"	1.656"	1.124"	4
22531	CAT50 x JT5 - 1.57"	1.57"	1.875"	1.413"	5
22523	CAT50 x JT6 - 1.57"	1.57"	.945"	.676"	6
22525	CAT50 x JT33 - 1.57"	1.57"	.945"	.624"	33

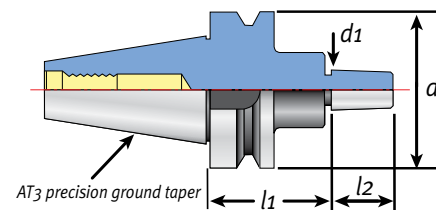

BT Toolholders For Jacobs Taper Drill Chucks

Part No.	Description	l1	l2	d1
16502	BT30 x JT2 - 45mm	45mm	20mm	14.199
16504	BT30 x JT33 - 45mm	45mm	24mm	15.850
16506	BT30 x JT6 - 45mm	45mm	24mm	17.170
16522	BT40 x JT2 - 45mm	45mm	20mm	14.199
16523	BT40 x JT33 - 45mm	45mm	24mm	15.850
16524	BT40 x JT6 - 45mm	45mm	24mm	17.170
16542	BT50 x JT2 - 45mm	45mm	20mm	14.199
16543	BT50 x JT33 - 45mm	45mm	24mm	15.850
16544	BT50 x JT6 - 45mm	45mm	24mm	17.170

Capto-Compatible* Turn/Mill Toolholders

The C4, C5, C6, holders you need, Techniks Certified.



ER Collet Chucks



End Mill Holders



ShrinkFIT



Face Mill Arbors



Turning Tools & Inserts



SlimFIT Holders



Built for Speed.

*Compatible with Capto tool system. Techniks products are not affiliated with or endorsed by Sadvik AB.

Capto-Compatible* C4, C5, C6, ER Collet Chucks



Features

- *Balanced to 25,000 RPM at G2.5*
- *T.I.R. 0.0001" or better*
- *PowerCOAT Nut included!*

Friction-reducing PowerCOAT nut provides 75% greater clamping power than standard nuts for improved rigidity, accuracy, and extended tool life.



Each toolholder is individually lab tested, inspected, and certified for quality.

An individual inspection report comes with each holder documenting accuracy and balance.

Techniks Certified toolholders are backed by our 100% Performance Guarantee.



For turn/mill machines that accept "C" style toolholders.

Coolant-thru is standard feature.

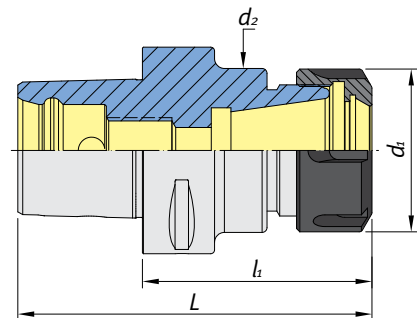

C4 ER Collet Chucks

Part No.	Description	L	l1	d1	d2	Size Range
141.122.16.070	C4 x ER16-70mm	94mm	70mm	28mm	28mm	1.0-10.0mm
141.122.25.052	C4 x ER25-52mm	76mm	52mm	42mm	42mm	1.0-16.0mm
141.122.32.054	C4 x ER32-54mm	78mm	54mm	50mm	50mm	2.0-20.0mm

C5 ER Collet Chucks

Part No.	Description	L	l1	d1	d2	Size Range
142.122.16.100	C5 x ER16-100mm	130mm	100mm	28mm	28mm	1.0-10.0mm
142.122.25.055	C5 x ER25-55mm	82mm	55mm	42mm	42mm	1.0-16.0mm
142.122.32.057	C5 x ER 32-57mm	84mm	57mm	50mm	50mm	2.0-20mm

C6 ER Collet Chucks

Part No.	Description	L	l1	d1	d2	Size Range
143.122.16.100	C6 x ER16-100mm	138mm	100mm	28mm	28mm	1.0-10.0mm
143.122.25.060	C6 x ER25-60mm	98mm	60mm	42mm	42mm	1.0-16.0mm
143.122.32.070	C6 x ER32-70mm	108mm	70mm	50mm	50mm	2.0-20.0mm
143.122.40.065	C6 x ER40-65mm	103mm	65mm	63mm	63mm	3.0-26.0mm
143.123.08.600	C6 x ER8M-6"	190mm	6"	12mm	16mm	0.5-5.0mm
143.123.11.600	C6 x ER11M-6"	190mm	6"	19mm	20mm	0.5-7.0mm
143.123.16.600	C6 x ER16M-6"	190mm	6"	22mm	25mm	1.0-10.0mm
143.123.20.600	C6 x ER20M-6"	190mm	6"	28mm	32mm	2.0-16.0mm

*Compatible with the Capto tool system. Techniks products are not affiliated with or endorsed by Sandvik AB.

Capto-Compatible* C4, C6, SlimFIT Collet Chucks



Features

- Powerful drawbar clamping and 4° collet maximizes holding power on tool shank
- Maximum T.I.R. 0.0001"
- Balanced to 25,000 RPM at G2.5



For turn/mill machines that accept "C" style toolholders.
Coolant-thru is standard feature.



Use SlimFIT for tight clearance situations.

Each toolholder is individually lab tested, inspected, and certified for quality.

An individual inspection report comes with each holder documenting accuracy and balance.

Techniks Certified toolholders are backed by our 100% Performance Guarantee.

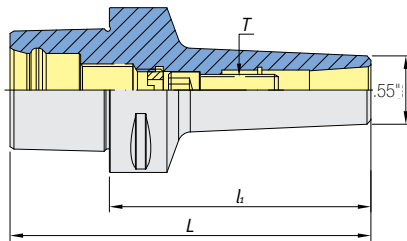

SlimFIT Collet Set

Part No.	Description
18851-12IMS	SlimFIT 6 - 12 pc. set
1/8" – 1/4" by 64ths (except no 5/32 or 7/32) 3mm – 6mm by 1mm	

C4 & C6 SlimFIT Collet Chucks

Part No.	Description	L	l1	Drawbar
141.648.06.075	C4 x SBL 6–75mm	94mm	75mm	SBL-M6CT-20
143.648.06.080	C6 x SBL 6–80mm	118mm	80mm	SBL-M6CT-20



SlimFIT Inch Size Collets

Part No.	Description
18851-3/32	SlimFIT 6 - 3/32" collet
18851-7/64	SlimFIT 6 - 7/64" collet
18851-1/8	SlimFIT 6 - 1/8" collet
18851-9/64	SlimFIT 6 - 9/64" collet
18851-5/32	SlimFIT 6 - 5/32" collet
18851-11/64	SlimFIT 6 - 11/64" collet
18851-3/16	SlimFIT 6 - 3/16" collet
18851-13/64	SlimFIT 6 - 13/64" collet
18851-7/32	SlimFIT 6 - 7/32" collet
18851-15/64	SlimFIT 6 - 15/64" collet
18851-1/4	SlimFIT 6 - 1/4" collet

SlimFIT Extensions



- Use with any toolholder
- Extremely accurate drawbar collet
- Use with SlimFIT 6 collets

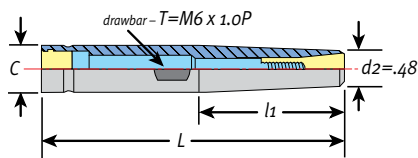

SlimFIT Extensions

Part No.	Description	L	l1	C
06032-3	1/2" x OLP6-3" extension	3"	1.89"	.50"
06032	1/2" x OLP6-5" extension	5"	1.89"	.50"
06034	1/2" x OLP6-6" extension	6"	1.89"	.50"
06038	5/8" x OLP6-5" extension	5"	1.89"	.625"
06040	5/8" x OLP6-6" extension	6"	1.89"	.625"
06042	5/8" x OLP6-8" extension	8"	1.89"	.625"

SlimFIT Metric Size Collets

Part No.	Description
18851-03	SlimFIT 6 - 3mm collet
18851-04	SlimFIT 6 - 4mm collet
18851-05	SlimFIT 6 - 5mm collet
18851-05.5	SlimFIT 6 - 5.5mm collet
18851-06	SlimFIT 6 - 6mm collet

*Compatible with the Capto tool system. Techniks products are not affiliated with or endorsed by Sandvik AB.



Capto-Compatible* C4, C6, Endmill Holders



Features

- High precision bore (H5) is best in the industry
- Extends cutting tool life 60%
- Balanced to 15,000 RPM at G6.3



Each toolholder is individually lab tested, inspected, and certified for quality.

An individual inspection report comes with each holder documenting accuracy and balance.

Techniks Certified toolholders are backed by our 100% Performance Guarantee.

Techniks H5 Bore Tolerance Extends Tool Life 60%
You lose 10% of cutting tool life for every .0001" of T.I.R.

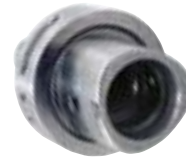
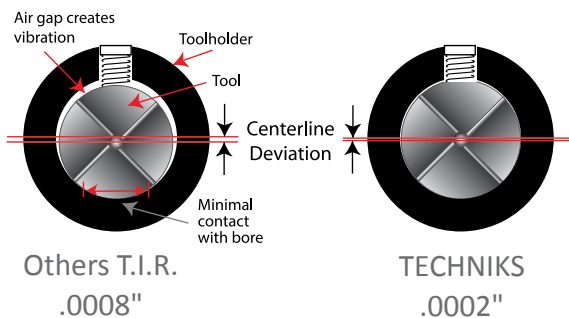

For turn/mill machines that accept "C" style toolholders.

Coolant-thru is standard feature.

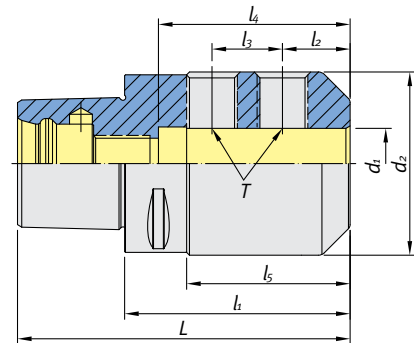

C4 Endmill Holders

Part No.	Description	L	I1	I2	I4	I5	d1	d2	T
141.653.54.197	C4 x SLN 1/4"-1.97"	2.91"	1.97"	0.63"	1.38"	1"	0.25"	0.78"	1/4-28"
141.653.55.197	C4 x SLN 5/16"-1.97"	2.91"	1.97"	0.63"	1.38"	1.02"	0.3125"	0.88"	5/16-24"
141.653.56.197	C4 x SLN 3/8"-1.97"	2.91"	1.97"	0.75"	1.535"	1.08"	0.375"	1"	3/8-24"
141.653.58.217	C4 x SLN 1/2"-2.17"	3.11"	2.17"	0.875"	1.732"	1.42"	0.5"	1.25"	7/16-20"
141.653.61.217	C4 x SLN 5/8"-2.17"	3.11"	2.17"	0.875"	1.732"	1.54"	0.625"	1.5"	7/16-20"

C6 Endmill Holders

Part No.	Description	L	I1	I2	I3	I4	I5	d1	d2	T
143.653.54.217	C6 x SLN 1/4"-2.17"	3.66"	2.17"	0.63"	-	1.38"	0.984"	0.25"	0.78"	1/4-28"
143.653.55.217	C6 x SLN 5/16"-2.17"	3.66"	2.17"	0.63"	-	1.38"	1.024"	0.3125"	0.88"	5/16-24"
143.653.56.236	C6 x SLN 3/8"-2.36"	3.86"	2.36"	0.75"	-	1.535"	1.181"	0.375"	1"	3/8-24"
143.653.58.236	C6 x SLN 1/2"-2.36"	3.86"	2.36"	0.875"	-	1.732"	1.299"	0.5"	1.25"	7/16-20"
143.653.61.256	C6 x SLN 5/8"-2.56"	4.06"	2.56"	0.937"	-	1.732"	1.398"	0.625"	1.5"	1/2-20"
143.653.64.256	C6 x SLN 3/4"-2.56"	4.06"	2.56"	1"	-	1.929"	1.476"	0.75"	1.75"	5/8-18"
143.653.68.315	C6 x SLN 1" -3.15"	4.65"	3.15"	1.125"	1"	2.559"	2.283"	1"	2"	3/4-16"
143.653.72.354	C6 x SLN 1-1/4" -3.54"									

*Compatible with the Capto tool system. Techniks products are not affiliated with or endorsed by Sandvik AB.

Capto-Compatible* C4, C5, C6, ShrinkFIT Holders



For turn/mill machines that accept "C" style toolholders.

Coolant-thru is standard feature.



Features

- Maximum T.I.R. only 0.0001"
- Balanced to 25,000 RPM at G2.5
- Superior rigidity and holding power

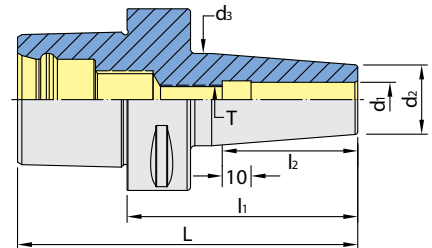

C4 ShrinkFIT Chucks

Part No.	Description	L	l1	l2	d1	d2	d3	T
141.651.54.295	C4 x SF 1/4"-2.95"	3.9"	2.95"	1.41"	0.3125"	0.83"	1.06"	M5 x 0.8P
141.651.55.295	C4 x SF 5/16"-2.95"	3.9"	2.95"	1.41"	0.3125"	0.83"	1.06"	M6 x 1.0P
141.651.56.295	C4 x SF 3/8"-2.95"	3.9"	2.95"	1.61"	0.375"	0.95"	1.26"	M8 x 1.25P
141.651.58.295	C4 x SF 1/2"-2.95"	3.9"	2.95"	1.81"	0.5"	1.10"	1.34"	M10 x 1.5P
141.651.61.315	C4 x SF 5/8"-3.15"	4.09"	3.15"	1.93"	0.625"	1.06"	1.34"	M12 x 1.75P

C5 ShrinkFIT Chucks

Part No.	Description	L	l1	l2	d1	d2	d3	T
142.651.52.315	C5 x SF 1/8"-80mm	110mm	80mm	38mm	1/8"	16mm	22mm	M6 x 1.0P
142.651.53.315	C5 x SF 3/16"-80mm	110mm	80mm	38mm	3/16"	16mm	22mm	M6 x 1.0P
142.651.54.315	C5 x SF 1/4"-80mm	110mm	80mm	38mm	1/4"	21mm	27mm	M5 x 0.8P
142.651.56.315	C5 x SF 3/8"-80mm	110mm	80mm	51mm	3/8"	24mm	32mm	M8 x 1.25P
142.651.58.315	C5 x SF 1/2"-80mm	110mm	80mm	38mm	1/2"	28mm	34mm	M10 x 1.5P
142.651.61.315	C5 x SF 5/8"-80mm	110mm	80mm	44.5mm	5/8"	27mm	34mm	M12 x 1.75P
142.651.64.315	C5 x SF 3/4"-80mm	110mm	80mm	38mm	3/4"	36mm	42mm	M16 x 2.0P

C6 ShrinkFIT Chucks

Part No.	Description	L	l1	l2	d1	d2	d3	T
143.651.52.300	C6 x SF 1/8"-3"	4.50"	3"	1.77"	0.125"	0.36"	0.64"	M6 x 1.0P
143.651.53.300	C6 x SF 3/16"-3"	4.50"	3"	1.77"	0.137"	0.43"	0.70"	M6 x 1.0P
143.651.54.315	C6 x SF 1/4"-3.15"	4.65"	3.15"	1.41"	0.3125"	0.83"	1.06"	M5 x 0.8P
143.651.55.315	C6 x SF 5/16"-3.15"	4.65"	3.15"	1.41"	0.3125"	0.83"	1.06"	M6 x 1.0P
143.651.56.315	C6 x SF 3/8"-3.15"	4.65"	3.15"	1.61"	0.375"	0.95"	1.26"	M8 x 1.25P
143.651.58.315	C6 x SF 1/2"-3.15"	4.65"	3.15"	1.81"	0.5"	1.10"	1.34"	M10 x 1.5P
143.651.61.335	C6 x SF 5/8"-3.35"	4.84"	3.35"	1.93"	0.625"	1.06"	1.34"	M12 x 1.75P
143.651.64.335	C6 x SF 3/4"-3.35"	4.84"	3.35"	2"	0.75"	1.26"	1.65"	M16 x 2.0P
143.651.68.354	C6 x SF 1"-3.54"	5.04"	3.54"	2.24"	1"	1.73"	2.08"	M16 x 2.0P
143.651.72.374	C6 x SF 1-1/4"-3.74"	5.24"	3.74"	2.4"	1.25"	1.73"	2.08"	M16 x 2.0P

*Compatible with the Capto tool system. Techniks products are not affiliated with or endorsed by Sandvik AB.



Capto-Compatible* C4, C5, C6, Face Mill Arbors



Features

- Compatible with all face mills
- H6 arbor tolerance for less chatter & better tool life
- Techniks Certified for accuracy and balance and backed by our 100% Performance guarantee



For turn/mill machines that accept "C" style toolholders.
Coolant-thru is standard feature.

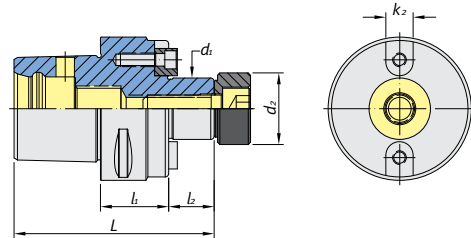

C4, C5, C6 Face Mill Arbors

Part No.	Description	L	I1	I2	d1	d2	k2
141.151.64.100	C4 x FMA 3/4"-1"	3.13"	1"	0.687"	3/4"	0.88"	0.314"
142.151.68.157	C5 x FMA 1"-1.57"	3.43"	1.57"	0.687"	1"	1.24"	0.375"
143.151.64.100	C6 x FMA 3/4"-1"	3.18"	1"	0.687"	3/4"	0.88"	0.314"
143.151.68.200	C6 x FMA 1"-2"	4.18"	2"	0.687"	1"	1.24"	0.375"
143.151.72.200	C6 x FMA 1-1/4"-2"	4.18"	2"	0.687"	1.25"	1.614"	0.5"

CoolBLAST Coolant Arbor Screws



- Use with Techniks face mill arbors
- Works with coolant thru face mills
- For coolant up to 1,500 PSI



CoolBLAST arbor screw provides coolant path.

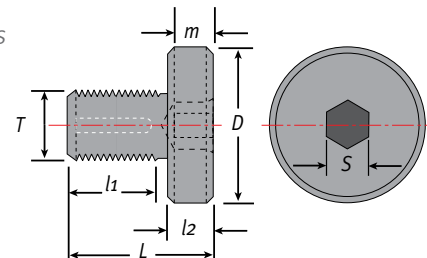

Part No.	Description	Style	Size	D	L	I1	I2	T	S	m
WF.C1-0.75	CoolBLAST arbor screw 3/4"	B	3/4"	7/8"	1.8"	1.4"	.37"	3/8"-24UNF	1/4"	.197"
9851125	CAS-A-0.75 Smaller "D"	A	3/4"	5/8"	1.375"	1.0"	.36"	3/8"-24 UNF	1/4"	.37"
WF.C1-1	CoolBLAST arbor screw 1.0"	B	1.0"	1-3/16"	1.4"	0.81"	.37"	1/2"-20UNF	5/16"	.197"
9851135	CAS-A-1.00 Smaller "D"	A	1.0"	3/4"	1.375"	1.0"	.38"	1/2"-20UNF	5/16"	.37"
WF.C1-1.25	CoolBLAST arbor screw 1-1/4"	B	1-1/4"	1-1/2"	1.44"	0.94"	.5"	5/8"-18UNF	5/16"	.236"

Blue indicates coolant.

Standard Arbor Screws

Part No.	Description	Arbor Size	D	L	I1	I2	T	S	m
WF0.75	FMA arbor screw 3/4"	3/4"	7/8"	1.8"	1.4"	.37"	3/8"-24UNF	1/4"	.197"
WF1	FMA arbor screw 1.0"	1.0"	1-3/16"	1.4"	0.81"	.37"	1/2"-20UNF	5/16"	.197"
WF1.25	FMA arbor screw 1-1/4"	1-1/4"	1-1/2"	1.44"	0.94"	.5"	5/8"-18UNF	5/16"	.236"

*Compatible with the Capto tool system. Techniks products are not affiliated with or endorsed by Sandvik AB.

Capto-Compatible* C6 External Turning Tools



For turn/mill machines that accept "C" style toolholders.

Features

- High accuracy for best repeatability
- Turning, boring, threading and grooving

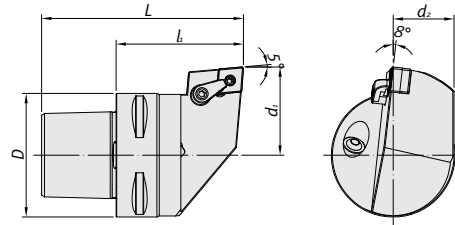

C6 MCLN



Part No.	Description	L	l1	D	d1	d2	Insert	Clamp	Shim	Screw	Lock Pin
143.475.12L.065	C6-MCLNL-DX12	103	65	63	45	31	CN_43_	MC620	CMS432	MS630	MLP46-A
143.475.12R.065	C6-MCLNR-DX12	103	65	63	45	31	CN_43_	MC620	CMS432	MS630	MLP46-A

CNMG Inserts for Negative Turning and Boring

Part No.	Description	Grade	Radius	Operation	Material
6607029	CNMG431-NN	LT10	0.016	finishing	P-M-K-S-H
6608011	CNMG431-NN	LT1000	0.016	finishing	P-M-K-S-H
6607033	CNMG432-NN	LT10	0.031	general	P-M-K-S-H
6608016	CNMG432-NN	LT1000	0.031	general	P-M-K-S-H
6601436	CNMG432-NM	LT10	0.031	roughing	P-M-K-S-H
6601446	CNMG432-NR	LT10	0.031	roughing	P-M-K-S-H
6608026	CNMG432-NX	LT1000	0.031	general	P-M-K-S-H
6607037	CNMG433-NN	LT10	0.047	roughing	P-M-K-S-H
6608021	CNMG433-NN	LT1000	0.047	roughing	P-M-K-S-H

We recommend LT1000 grade inserts for maximum insert performance. LT1000 grade features an advanced PVD coating that is 14 microns thick and lasts 250% longer than other inserts.



CNMG

CNMM Inserts for Negative Turning and Boring

Part No.	Description	Grade	Radius	Operation	Material
6602011	CNMM432-NR	LT10	0.031	finish-medium	P-M-K-S-H
6602022	CNMM433-NR	LT10	0.047	medium-rough	P-M-K-S-H



CNMM

CNMP Inserts for Negative Turning and Boring

Part No.	Description	Grade	Radius	Operation	Material
6607045	CNMP432-NN	LT10	0.031	finish-medium	P-M-K-S-H
6608031	CNMP432-NN	LT1000	0.031	finish-medium	P-M-K-S-H
3665525	CNMP433-NN	LT10	0.047	medium-rough	P-M-K-S-H
6608036	CNMP433-NN	LT1000	0.047	medium-rough	P-M-K-S-H



CNMP

CNGG Inserts for Aluminum Negative Turning and Boring

Part No.	Description	Grade	Radius	Operation	Material
6607901	CNGG431-ALU	LT05	0.016	finishing	N
6607905	CNGG432-ALU	LT05	0.031	general	N



CNGG

*Compatible with the Capto tool system. Techniks products are not affiliated with or endorsed by Sandvik AB.

P = steel, M = stainless, K = cast iron, S = high temp alloys, H = hardened material, N = aluminum & alloys



Capto-Compatible* C6 External Turning Tools



For turn/mill machines that accept "C" style toolholders.

Features

- High accuracy for best repeatability
- Turning, boring, threading and grooving

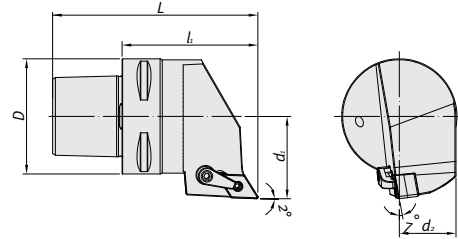

C6 MDJN



Part No.	Description	L	l1	D	d1	d2	Insert	Clamp	Shim	Screw	Lock Pin
143.476.15L.075	C6-MDJNL-EX15	113	75	63	45	31	DN_43_	MC622	DMS442	MS630	MLP46L-A
143.476.15R.075	C6-MDJNR-EX15	113	75	63	45	31	DN_43_	MC622	DMS442	MS630	MLP46L-A

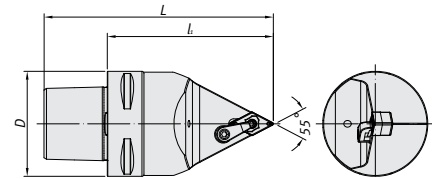

C6 MDNN



Part No.	Description	L	l1	D	Insert	Clamp	Shim	Screw	Lock Pin
143.481.15N.100	C6-MDNNN-H15	138	100	63	DN_43_	MC622	DMS442	MS625	MLP46L-A

DNMG and DNGG Inserts for Negative Turning and Boring

Part No.	Description	Grade	Radius	Operation	Material
7607069	DNMG431-NN	LT10	0.016	finishing	P-M-K-S-H
7608021	DNMG431-NN	LT1000	0.016	finishing	P-M-K-S-H
7607073	DNMG432-NN	LT10	0.031	finish-medium	P-M-K-S-H
7608026	DNMG432-NN	LT1000	0.031	finish-medium	P-M-K-S-H
7608029	DNMG432-NX	LT1000	0.031	general	P-M-K-S-H
7607077	DNMG433-NN	LT10	0.047	medium-rough	P-M-K-S-H
7608031	DNMG433-NN	LT1000	0.047	medium-rough	P-M-K-S-H

We recommend LT1000 grade inserts for maximum insert performance. LT1000 grade features an advanced PVD coating that is 14 microns thick and lasts 250% longer than other inserts.

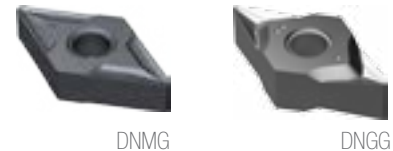

*Compatible with the Capto tool system. Techniks products are not affiliated with or endorsed by Sandvik AB.

P = steel, M = stainless, K = cast iron, S = high temp alloys, H = hardened material, N = aluminum & alloys

Capto-Compatible* C6 External Turning Tools



For turn/mill machines that accept "C" style toolholders.

Features

- High accuracy for best repeatability
- Turning, boring, threading and grooving

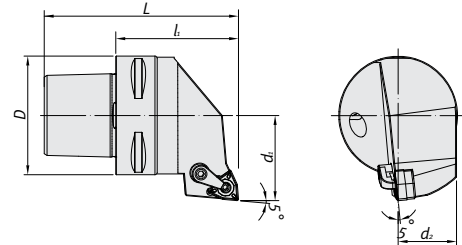

C6 MWLN



Part No.	Description	L	I1	D	d1	d2	Insert	Clamp	Shim	Screw	Lock Pin
143.478.08L.065	C6-MWLN-L-DX08	103	65	63	45	31	WN_43_	MC620	TMS432	MS630	MLP46L-A
143.478.08R.065	C6-MWLN-R-DX08	103	65	63	45	31	WN_43_	MC620	TMS432	MS630	MLP46L-A

WNMG Inserts for Negative Turning and Boring

Part No.	Description	Grade	Radius	Operation	Material
4607257	WNMG431-NN	LT10	0.016	finishing	P-M-K-S-H
4608011	WNMG431-NN	LT1000	0.016	finishing	P-M-K-S-H
4607261	WNMG432-NN	LT10	0.031	finish-medium	P-M-K-S-H
4608016	WNMG432-NN	LT1000	0.031	finish-medium	P-M-K-S-H
4608023	WNMG432-NM	LT1000	0.031	roughing	P-M-K-S-H
4601437	WNMG332-NR	LT10	0.031	roughing	P-M-K-S-H
4608021	WNMG432-NX	LT1000	0.031	general	P-M-K-S-H
4600076	WNMG432-WM	LT10	0.031	finish-medium	P-M-K-S-H
4607265	WNMG433-NN	LT10	0.047	medium-rough	P-M-K-S-H
4608026	WNMG433-NN	LT1000	0.047	medium-rough	P-M-K-S-H

We recommend LT1000 grade inserts for maximum insert performance. LT1000 grade features an advanced PVD coating that is 14 microns thick and lasts 250% longer than other inserts.



WNMG

WNMP Inserts for Negative Turning and Boring

Part No.	Description	Grade	Radius	Operation	Material
4607277	WNMP432-NN	LT10	0.031	finish-medium	P-M-K-S-H
4608031	WNMP432-NN	LT1000	0.031	finish-medium	P-M-K-S-H



WNMP

*Compatible with the Capto tool system. Techniks products are not affiliated with or endorsed by Sandvik AB.

P = steel, M = stainless, K = cast iron, S = high temp alloys, H = hardened material, N = aluminum & alloys

Capto-Compatible* C6 External Turning Tools



For turn/mill machines that accept "C" style toolholders.

Features

- High accuracy for best repeatability
- Turning, boring, threading and grooving

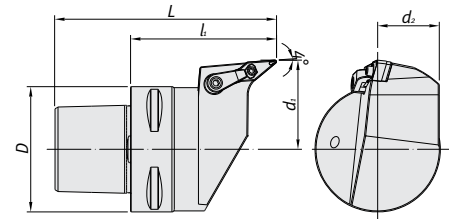

C6 MVLN



Part No.	Description	L	l1	D	d1	d2	Insert	Clamp	Shim	Screw	Screw
143.479.16L.075	C6-MVLNL-EX16	113	75	63	45	31	VN_33_	MC622	VMS322	MS630	MLP34L-A
143.479.16R.075	C6-MVLNR-EX16	113	75	63	45	31	VN_33_	MC622	VMS322	MS630	MLP34L-A

VNMG Inserts for Negative Turning and Boring

Part No.	Description	Grade	Radius	Operation	Material
8607241	VNMG331-NN	LT10	0.016	finishing	P-M-K-S-H
8608011	VNMG331-NN	LT1000	0.016	finishing	P-M-K-S-H
8607245	VNMG332-NN	LT10	0.031	finish-medium	P-M-K-S-H
8608016	VNMG332-NN	LT1000	0.031	finish-medium	P-M-K-S-H

We recommend LT1000 grade inserts for maximum insert performance. LT1000 grade features an advanced PVD coating that is 14 microns thick and lasts 250% longer than other inserts.



VNMG

VNGG Inserts for Aluminum Negative Turning and Boring

Part No.	Description	Grade	Radius	Operation	Material
8607921	VNGG331-ALU	LT 05	0.016	finishing	N
8607925	VNGG332-ALU	LT 05	0.031	finish-medium	N



VNGG

*Compatible with the Capto tool system. Techniks products are not affiliated with or endorsed by Sandvik AB.

P = steel, M = stainless, K = cast iron, S = high temp alloys, H = hardened material, N = aluminum & alloys

Tapping Systems – ANSI Tap Collets



MicroFLOAT

Rigid Tapping Holders

Increase Tap Life 295%



Tension-Compression Tap Holders

Automatically compensate for machine feed rates to improve results.



Rigid Tap Chucks

Easy to use and reliable tap holders for general tapping applications.



ANSI Clutch Drive & Rigid Tap Collets

Clutch drive automatically stops spinning if tap reaches bottom of hole preventing broken taps.



<http://ow.ly/rli2o>

View the MicroFLOAT Tapping video.



Built for Speed.

All Techniks products are backed by our 100% satisfaction guarantee!



Synchronous Feed Holders for Rigid Tap Cycles



MicroFLOAT Tap Holders

- *prevent broken taps*
- *increase tap life 295%*
- *improve thread quality*



Stop breaking so many taps

This graph shows how MicroFLOAT reduces stress on the tap during tapping cycle.

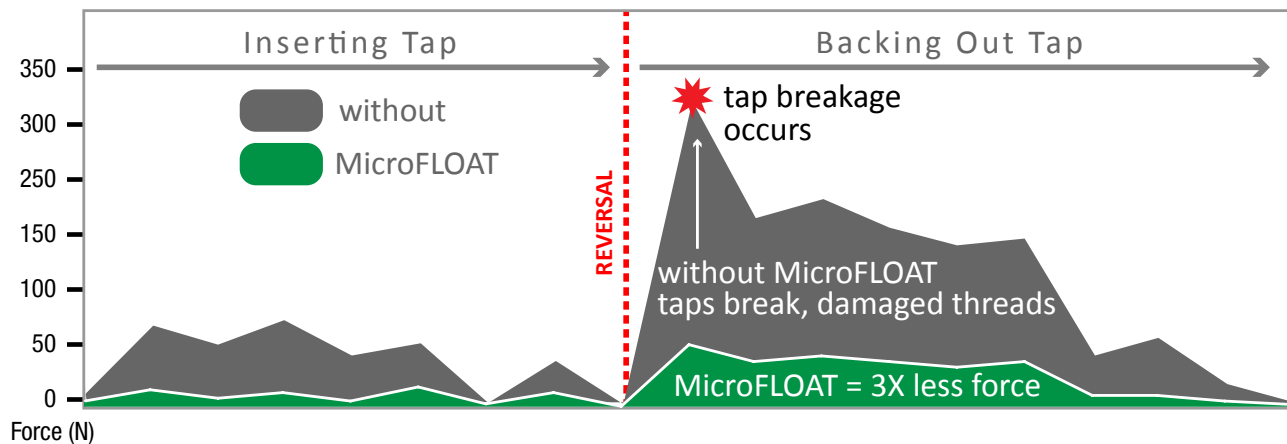

Synchronous feed eases the tap through the whole cycle, preventing breakage.

Synchronous Feed Holders for Rigid Tap Cycles

MicroFLOAT improves CNC Rigid Tapping

No matter how good your machine's tapping cycle is, there are always small mechanical variances that produce path inaccuracies during tapping. These variances cause wear on the tap, leading to premature tap failure and poor thread quality.

MicroFLOAT synchronous feed holders cushion the sudden shocks taps are subject to, minimizing damage to the tap. MicroFLOAT's ability to compensate for feed variances provides unmatched stability.

MicroFLOAT is the recommended solution for improving rigid tapping performance and extending tap life.

MicroFLOAT Test: 295% more holes per tap! You can expect similar results

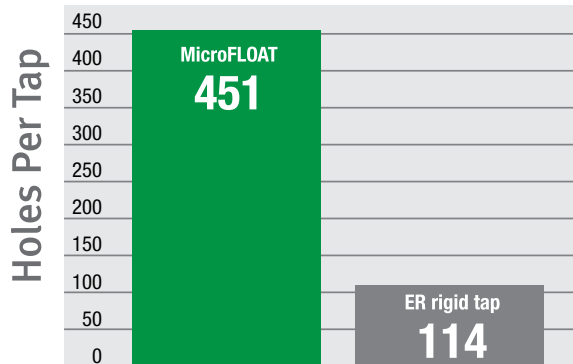

Machine: Mori Seiki SH403
Material: AISI 304
Coolant: 7% concentration
Cutting speed: 12m/min
Thread: M6; 12 mm depth
Tap: UFS, K82M6X-TXC

On a machining center we compared an ER rigid tap holder to a MicroFLOAT holder. The only difference was the tool holder. As you can see, the savings are significant. MicroFLOAT yields 337 more threaded holes per tap!

See MicroFLOAT in action...



<http://bit.ly/29e85vZ>

Key Technology Features

1. Synchronous Feed – In and Out



During the tapping cycle MicroFLOAT's synchronous feed technology automatically corrects for mechanical variances such as ballscrew play, spindle wear, or material irregularities to produce the truest possible threads. Internal steel spring compensation allows 0.008" (.2mm) of compression and 0.040" (1mm) of tension, effectively compensating for path inaccuracies and protecting the tap from metal fatigue and breaking. Because the tap follows the exact same path both in and out of the hole, optimum thread quality is achieved.

2. Quick-change Tap Adapters

Adapters make tap changes fast and easy. Change taps in spindle without presetting equipment.



3. Modular extensions achieve lengths up to 9"

Quickly combine adapters and extensions to create lengths up to 9 inches without sacrificing accuracy.



4. Coolant-thru technology

High-pressure (50 Bar) coolant through is standard.



We stand behind all our CNC tooling solutions from spindle to workpiece.

www.techniksusa.com 161

How to Order – MicroFLOAT Synchronous Feed Holders

MicroFLOAT Components

MicroFLOAT is an easy to use system that can be expanded to achieve lengths of 9" using extensions. Quick-change connection makes tap replacement fast and easy even in-spindle.

Refer to the diagram (right) to identify system components.

MicroFLOAT tap holders can be configured three ways:

- A using a holder with a quick-change tap adapter
- B holder with a modular body and modular tap adapter
- C holder with a modular body, extensions, and tap adapter

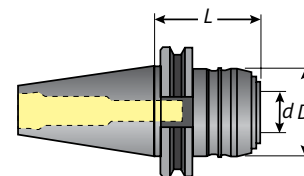
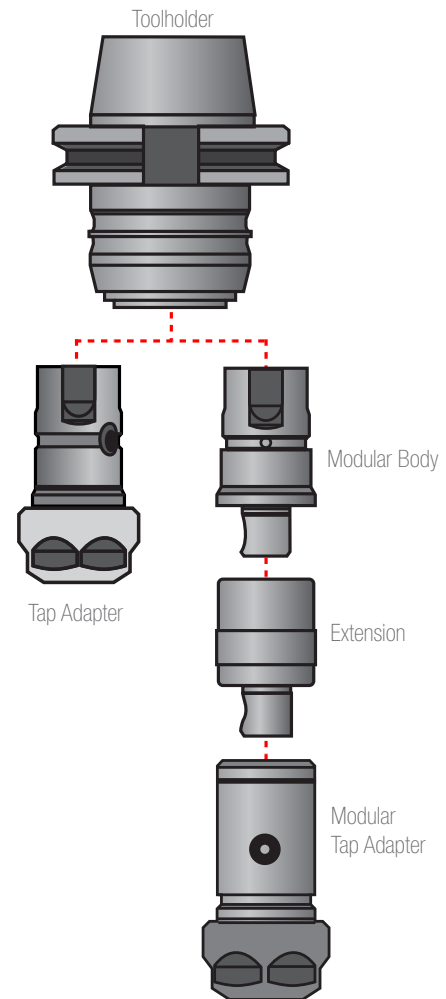
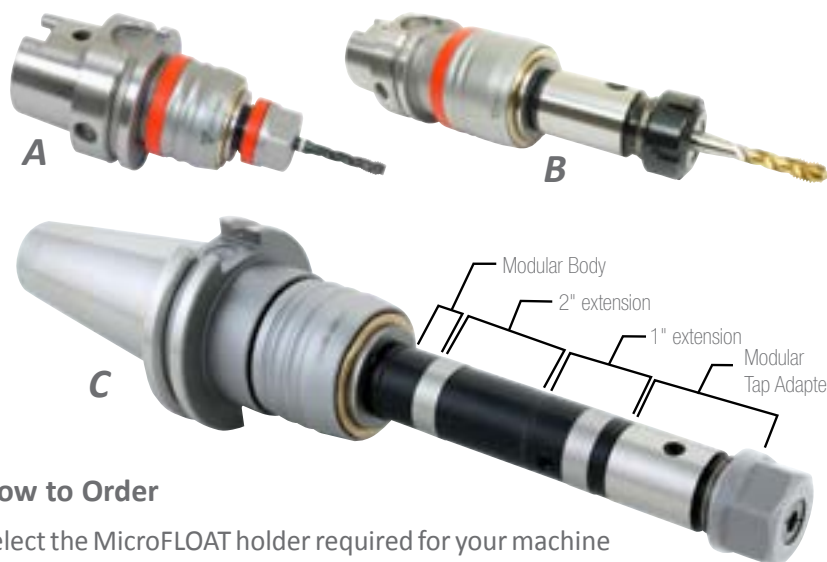

How to Order

Select the MicroFLOAT holder required for your machine spindle and tap size from the table (right).

NOTE: #1 holders fit our #1 ER16 tap adapters, which can hold tap sizes up to 3/8".

NOTE: #2 holders fit our #2 ER25 tap adapters, which can hold tap sizes up to 11/16".

For configuration **A**, (using a holder with a quick-change tap adapter) select the correct quick-change tap adapter from the table below.

For configurations **B** or **C**, select a modular body, extensions if needed, (1" or 2" available) and modular quick-change tap adapter from the tables on the next page.

Quick-Change Tap Adapter (use for configuration A)

ER16 fits taps up to 3/8"
ER25 fits taps up to 11/16"



Part No.	Description	L	D	d
23410-ER16	ER16 tap adapter #1	2.16"	1.10"	.79"
23610-ER25	ER25 tap adapter #2	3.39"	1.65"	1.27"

MicroFLOAT Toolholders

#1 holders fit #1 ER16 tap adapters and #1 components.

#2 holders fit #2 ER25 tap adapters and #2 components.

Part No.	Description	L	D	d
23400-40CAT	CAT40 holder #1	2.75"	1.7"	0.79"
23600-40CAT	CAT40 holder #2	3.54"	2.36"	1.26"
23400-50CAT	CAT50 holder #1	2.75"	1.7"	0.79"
23600-50CAT	CAT50 holder #2	3.54"	2.36"	1.26"
23400-30BT	BT30 holder #1	2.09"	1.7"	0.79"
23400-40BT	BT40 holder #1	2.40"	1.7"	1.26"
23600-40BT	BT40 holder #2	3.22"	2.36"	1.26"
23400-H63A	HSK63A holder #1	2.52"	1.7"	.79"
23400-INC1	1" Straight Shank holder # 1	1.3"	1.7"	0.79"
23600-INC1	1" Straight Shank holder # 2	2.13"	2.36"	1.26"

MicroFLOAT Components and ER Rigid Tap Collets



Modular components are sized #1 and #2

#1 holders fit #1 modular components

#2 holders fit #2 modular components



Modular Body

Part No.	Description	L	D	d
23411-MOD	Modular Body MicroFLOAT #1	.20"	.91"	.79"
23611-MOD	Modular Body MicroFLOAT #2	.28"	1.38"	1.26"

Modular Extensions

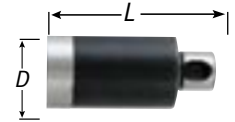

Part No.	Description	L	D	Chuck
42150-25	1" Mod. Extension #1	.98"	.91"	23400-..
42150-50	2" Mod. Extension #1	1.97"	.91"	23400-..
42250-50	2" Mod. Extension #2	1.97"	1.38"	23600-..
42250-100	4" Mod. Extension #2	3.94"	1.38"	23600-..

ER Modular Tap Adapters

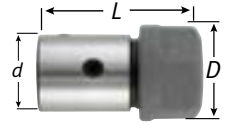

Part No.	Description	L	D	d
42147-ER16	ER16 Mod. Adapter #1	1.97"	1.10"	.91"
42247-ER25	ER25 Mod. Adapter #2	3.11"	1.65"	1.38"



- Square drive prevents spinning the tap
- High-carbon steel, heat treated for long life
- Precision ground and polished

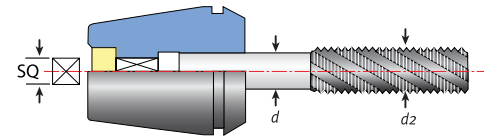

ER16, ER25 Rigid Tap Collets (inch)

Part No.	Size	d	SQ	Tap Size (d2)
05320-141	ER16	.141"	.110"	1/8" or #6
05320-168	ER16	.168"	.131"	5/32" or #8
05320-194	ER16	.194"	.152"	3/16" or #10
05320-220	ER16	.220"	.165"	7/32" or #12
05320-255	ER16	.255"	.191"	1/4"
05320-318	ER16	.318"	.238"	5/16"
05320-323	ER16	.323"	.242"	7/16"
05320-367	ER16	.367"	.275"	1/2"
05320-381	ER16	.381"	.286"	3/8"
05510-141	ER25	.141"	.110"	1/8" or #6
05510-168	ER25	.168"	.131"	5/32" or #8
05510-194	ER25	.194"	.152"	3/16" or #10
05510-220	ER25	.220"	.165"	7/32" or #12
05510-255	ER25	.255"	.191"	1/4"
05510-318	ER25	.318"	.238"	5/16"
05510-323	ER25	.323"	.242"	7/16"
05510-367	ER25	.367"	.275"	1/2"
05510-381	ER25	.381"	.286"	3/8"
05510-429	ER25	.429"	.322"	9/16"
05510-437	ER25	.437"	.328"	1/8" NPT
05510-480	ER25	.480"	.360"	5/8"
05510-542	ER25	.542"	.406"	11/16"

ER16, ER25 Rigid Tap Collets (metric)

Part No.	Size	d	SQ	Tap Size (d2)
05326-DIN	ER16	2.8	2.1	M4
05330-DIN	ER16	3.5	2.7	M3
05336-DIN	ER16	4.5	3.4	M4
05342-DIN	ER16	6	4.9	M5/M6
05350-DIN	ER16	8	6.2	M8
05352	ER16	8.5	6.5	M12
05354-DIN	ER16	9	7	M12
05356-DIN	ER16	10	8	M10
05371	ER16	6	4.5	M6
05385	ER16	6.2	5	M8
05526-DIN	ER25	4.5	3.4	M4
05534-DIN	ER25	6	4.9	M5/M6
05540-DIN	ER25	7	5.5	M10
05542-DIN	ER25	8	6.2	M8
05548-DIN	ER25	9	7	M12
05550	ER25	10	8	M10
05550-DIN	ER25	10	8	M10
05554-DIN	ER25	11	9	M14
05558-DIN	ER25	12	9	M16



We stand behind all our CNC tooling solutions from spindle to workpiece.

www.techniksusa.com 163

CAT, BT Tension / Compression Tap Holders



Techniks Quality Features

- Adjustable compression helps start difficult taps
- Taper ground to AT3 accuracy or better
- Quick-Change Style



ANSI Tap
Collets
pg. 169



Tightening
Stands
pg. 234



Retention
Knobs
pg. 228



Wrenches
pg. 232

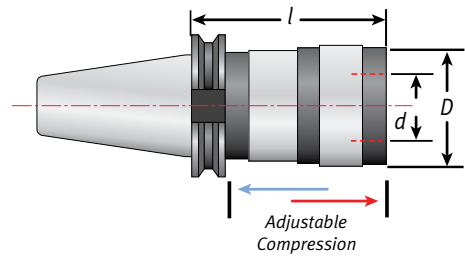

CAT Tension / Compression Tap Holders

Part No.	Description	d	D	l	Size	Tap	Compensation	
						Capacity	Tension	Compression
32400/40CAT	CAT40 T/C Holder, Size 1	0.748"	1.5"	2.36"	1	0 – 9/16"	0.35"	0.35"
32400/50CAT	CAT50 T/C Holder, Size 1	0.748"	1.5"	2.44"	1	0 – 9/16"	0.35"	0.35"
32600/40CAT	CAT40 T/C Holder, Size 2	1.220"	2.17"	3.94"	2	5/16 – 7/8"	0.59"	0.59"
32600/50CAT	CAT50 T/C Holder, Size 2	1.220"	2.17"	3.27"	2	5/16 – 7/8"	0.59"	0.59"
32800/40CAT	CAT40 T/C Holder, Size 3	1.890"	3.11"	5.43"	3	1/2 – 1-3/8"	0.94"	0.94"
32800/50CAT	CAT50 T/C Holder, Size 3	1.890"	3.11"	5.24"	3	1/2 – 1 3/8"	0.94"	0.94"
32900/40CAT	CAT40 T/C Holder, Size 4	2.362"	3.86"	6.06"	4	1-7/16 – 1-7/8"	1.02"	1.02"
32900/50CAT	CAT50 T/C Holder, Size 4	2.362"	3.86"	5.79"	4	1-7/16 – 1-7/8"	1.02"	1.02"

BT Tension / Compression Tap Holders

Part No.	Description	d	D	l	Size	Tap	Compensation	
						Capacity	Tension	Compression
32400/30BT	BT30 T/C Holder, Size 1	0.748"	1.5"	2.48"	1	0 – 9/16"	0.35"	0.35"
32400/40BT	BT40 T/C Holder, Size 1	0.748"	1.5"	2.68"	1	0 – 9/16"	0.35"	0.35"
32400/50BT	BT50 T/C Holder, Size 1	0.748"	1.5"	3.15"	1	0 – 9/16"	0.35"	0.35"
32600/30BT	BT30 T/C Holder, Size 2	1.220"	2.17"	3.78"	2	5/16 – 7/8"	0.59"	0.59"
32600/40BT	BT40 T/C Holder, Size 2	1.220"	2.17"	3.66"	2	5/16 – 7/8"	0.59"	0.59"
32600/50BT	BT50 T/C Holder, Size 2	1.220"	2.17"	4.02"	2	5/16 – 7/8"	0.59"	0.59"
32800/40BT	BT40 T/C Holder, Size 3	1.890"	3.11"	5.43"	3	1/2 – 1-3/8"	0.94"	0.94"
32800/50BT	BT50 T/C Holder, Size 3	1.890"	3.11"	5.31"	3	1/2 – 1-3/8"	0.94"	0.94"
32900/40BT	BT40 T/C Holder, Size 4	2.362"	3.86"	6.18"	4	1-7/16 – 1-7/8"	1.02"	1.02"
32900/50BT	BT50 T/C Holder, Size 4	2.362"	3.86"	5.79"	4	1-7/16 – 1-7/8"	1.02"	1.02"

HSK & Straight Shank Tension / Compression Tap Holders



Techniks Quality Features

- Adjustable compression helps start difficult taps
- Quick-Change Style

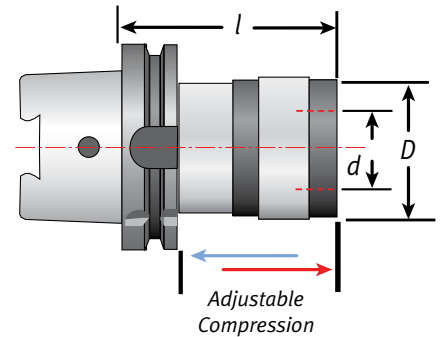

HSK A Tension / Compression Tap Holders

Part No.	Description	d	D	l	Size	Tap Capacity	Compensation	
							Tension	Compression
34400/H40A	HSK40A T/C Holder, Size 1	0.748"	1.5"	3.14"	1	0 – 9/16"	0.295"	0.295"
34400/H50A	HSK50A T/C Holder, Size 1	0.748"	1.5"	2.83"	1	0 – 9/16"	0.295"	0.295"
34400/H63A	HSK63A T/C Holder, Size 1	0.748"	1.5"	2.83"	1	0 – 9/16"	0.295"	0.295"
34400/H100A	HSK100A T/C Holder, Size 1	0.748"	1.5"	3.14"	1	0 – 9/16"	0.295"	0.295"
34600/H50A	HSK50A T/C Holder, Size 2	1.22"	2.17"	4.33"	2	5/16 – 7/8"	0.393"	0.393"
34600/H63A	HSK63A T/C Holder, Size 2	1.22"	2.17"	4.33"	2	5/16 – 7/8"	0.393"	0.393"
34600/H100A	HSK100A T/C Holder, Size 2	1.22"	2.17"	3.94"	2	5/16 – 7/8"	0.393"	0.393"

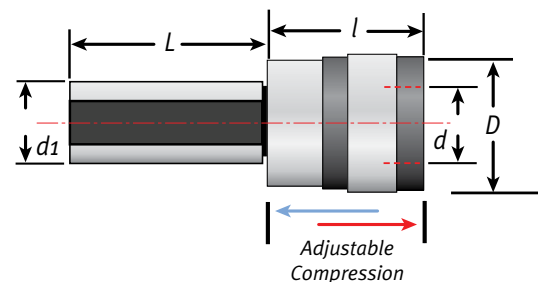

Straight Shank Tapping Chucks

Part No.	Description	D1	D	l	L	Tap Capacity	Compensation	
							Tension	Compression
32400/INC1	1" shank T/C Holder, Size 1	1.00"	1.5"	1.76"	1.95"	0 – 9/16"	0.35"	0.35"
32600/INC1	1" shank T/C Holder, Size 2	1.00"	2.17"	2.52"	2.00"	5/16 – 7/8"	0.59"	0.59"
32600/INC1-1/2	1 1/2" shank T/C Holder, Size 2	1.50"	2.17"	2.52"	3.50"	5/16 – 7/8"	0.59"	0.59"
32800/INC1-1/2	1 1/2" shank T/C Holder, Size 3	1.50"	3.38"	3.85"	3.50"	1/2 – 1 3/8"	0.94"	0.94"



CAT, BT Rigid Tap Holders



Techniks Quality Features

- Taper ground to AT3 accuracy or better
- Quick-Change Style



ANSI Tap
Collets
pg. 169



Tightening
Stands
pg. 234



Retention
Knobs
pg. 228



Wrenches
pg. 232

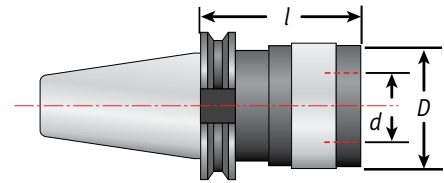

CAT Rigid Tap Holders

Part No.	Description	l	D	d	Size	Tap Capacity
21480/40CAT	CAT40 Rigid Tap Holder, Size 1	2.59"	1.31"	0.748"	1	0 – 9/16"
21480/50CAT	CAT50 Rigid Tap Holder, Size 1	2.95"	1.31"	0.748"	1	0 – 9/16"
21680/40CAT	CAT40 Rigid Tap Holder, Size 2	3.23"	1.97"	1.22"	2	5/16 – 7/8"
21680/50CAT	CAT50 Rigid Tap Holder, Size 2	3.86"	1.97"	1.22"	2	5/16 – 7/8"
21880/40CAT	CAT40 Rigid Tap Holder, Size 3	4.80"	2.83"	1.89"	3	1/2 – 1 3/8"
21880/50CAT	CAT50 Rigid Tap Holder, Size 3	4.80"	2.83"	1.89"	3	1/2 – 1 3/8"

BT Rigid Tap Holders

Part No.	Description	l	D	d	Size	Tap Capacity
21480/30BT	BT30 Rigid Tap Holder, Size 1	2.80"	1.31"	0.748"	1	0 - 9/16"
21480/40BT	BT40 Rigid Tap Holder, Size 1	2.63"	1.31"	0.748"	1	0 - 9/16"
21480/50BT	BT50 Rigid Tap Holder, Size 1	3.07"	1.31"	0.748"	1	0 - 9/16"
21680/30BT	BT30 Rigid Tap Holder, Size 2	3.70"	1.97"	1.22"	2	5/16 - 7/8"
21680/40BT	BT40 Rigid Tap Holder, Size 2	3.54"	1.97"	1.22"	2	5/16 - 7/8"
21680/50BT	BT50 Rigid Tap Holder, Size 2	3.97"	1.97"	1.22"	2	5/16 - 7/8"
21880/40BT	BT40 Rigid Tap Holder, Size 3	4.61"	2.83"	1.89"	3	1/2 - 1 3/8"
21880/50BT	BT50 Rigid Tap Holder, Size 3	4.80"	2.83"	1.89"	3	1/2 - 1 3/8"

HSK and Straight Shank Rigid Tap Holders



Techniks Quality Features

- Quick-Change Style

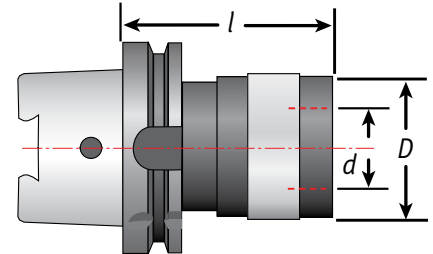

HSK Rigid Tap Holders

Part No.	Description	l	D	d	Size	Tap Capacity
21480/H50A	HSK50A Rigid Tap Holder, Size 1	2.30"	1.31"	0.748"	1	0 - 9/16"
21480/H63A	HSK63A Rigid Tap Holder, Size 1	2.32"	1.31"	0.748"	1	0 - 9/16"
21480/H100A	HSK100A Rigid Tap Holder, Size 1	2.95"	1.31"	0.748"	1	0 - 9/16"
21680/H50A	HSK50A Rigid Tap Holder, Size 2	3.23"	1.97"	1.22"	2	5/16 - 7/8"
21680/H63A	HSK63A Rigid Tap Holder, Size 2	3.23"	1.97"	1.22"	2	5/16 - 7/8"
21680/H100A	HSK100A Rigid Tap Holder, Size 2	3.86"	1.97"	1.22"	2	5/16 - 7/8"
21880/H63A	HSK63A Rigid Tap Holder, Size 3	4.80"	2.83"	1.89"	3	1/2 - 1 3/8"
21880/H100A	HSK100A Rigid Tap Holder, Size 3	4.80"	2.83"	1.89"	3	1/2 - 1 3/8"

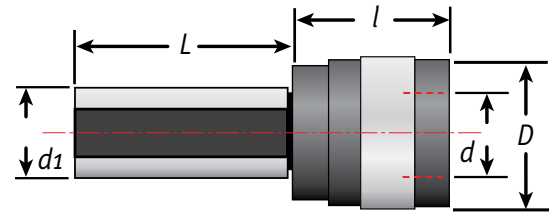

Straight Shank Rigid Tap Holders

Part No.	Description	d1	L	l	D	d	Tap Capacity
21480/INC1	1" shank, Rigid Tap Holder, Size 1	1.00"	1.95"	1.60"	1.31"	.748"	0 - 9/16"
21680/INC1	1" shank, Rigid Tap Holder, Size 2	1.00"	2.00"	2.50"	1.97"	1.22"	3/8 - 7/8"
21880/INC1-1/2	1 1/2" shank, Rigid Tap Holder, Size 3	1.50"	3.50"	3.44"	2.83"	1.89"	1/2 - 1 3/8"



ANSI Clutch Drive Tap Collets



Note: Metric tap collets available on request. Please verify shank diameter when ordering metric tap collets.

ANSI Clutch Drive Tap Collet Features

- Prevents broken taps
- Automatically stops spinning when bottom is reached
- Change worn taps in seconds

Dimensions	A	B	C	D	E
Size 0	.51"	.77"	.83"	.91"	.24"
Size 1	.75"	.85"	.98"	1.26"	.31"
Size 2	1.22"	1.38"	1.34"	1.97"	.16"
Size 3	1.89"	2.19"	1.77"	2.83"	.04"

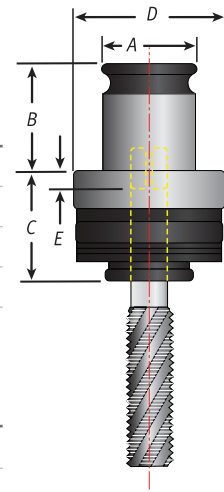

Collet Set

Part No.	Description
48/3-SET	Size 3, 16 piece set – 1/2" thru 1" NPT

ANSI Clutch Drive Tap Collets

ANSI	Metric Tap / ANSI Shank	Shank	SQ	Size 0	Size 1	Size 2	Size 3
0-6"	M1.6-M3.5	0.141"	0.110"	13/0-4036	19/1-4036		
8, 5/32"	M4	0.168"	0.131"	13/0-4041	19/1-4041		
10, 3/16"	M4.5, M5	0.194"	0.152"	13/0-4048	19/1-4048		
12, 7/32"		0.220"	0.165"	13/0-4054	19/1-4054		
1/4"	M6, M6.3	0.255"	0.191"	13/0-4063	19/1-4063		
5/16"	M7, M8	0.318"	0.238"		19/1-4079	31/2-4079	
3/8"	M10	0.381"	0.286"		19/1-4095	31/2-4095	
7/16"	M11	0.323"	0.242"		19/1-4111	31/2-4111	
1/2"	M12, M12.5	0.367"	0.275"		19/1-4127	31/2-4127	48/3-4127
9/16"	M14	0.429"	0.322"		19/1-4142	31/2-4142	48/3-4142
5/8"	M16	0.480"	0.360"			31/2-4158	48/3-4158
11/16"	M18	0.542"	0.406"			31/2-4174	48/3-4174
3/4"		0.590"	0.442"			31/2-4190	48/3-4190
13/16"	M20	0.652"	0.489"			31/2-4206	48/3-4206
7/8"	M22	0.697"	0.523"			31/2-4222	48/3-4222
15/16"	M24	0.760"	0.570"				48/3-4238
1"	M25	0.800"	0.600"				48/3-4254
1 1/8, 1 1/16"	M27	0.896"	0.672"				48/3-4286
1 1/4, 1 3/16"	M30	1.021"	0.766"				48/3-4317
1 3/8, 1 5/16"	M33	1.108"	0.831"				48/3-4349
1/8" NPT		0.437"	0.328"		19/1 - 4097		
1/4" NPT		0.562"	0.421"			31/2-4131C	
3/8" NPT		0.700"	0.531"			31/2-4166C	48/3-4166C
1/2" NPT		0.687"	0.515"			31/2-4209C	48/3-4209C
3/4" NPT		0.906"	0.678"				48/3-4264C
1" NPT		1.125"	0.843"				48/3-4332C

ANSI Rigid Tap Collets



- Change worn taps in seconds
- Quick-Change Style

Dimensions	A	B	C	D	E
Size 1	.75"	.85"	.28"	1.18"	.39"
Size 2	1.22"	1.38"	.43"	1.81"	.75"
Size 3	1.89"	2.19"	.55"	2.68"	1.18"
Size 4	2.36"	2.48"	1.65"	3.27"	1.14"

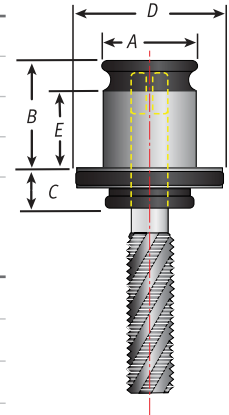

Collet Sets

Part No.	Description
19/11-SET	Size 1, 11 piece set – 0-6" thru 9/16" & 1/8" NPT
31/12-SET	Size 2, 13 piece set – 5/16" thru 1/2" NPT
48/13-SET	Size 3, 16 piece set – 1/2" thru 1" NPT

ANSI Rigid Tap Collets

ANSI	Metric Tap / ANSI Shank	Shank	SQ	Size 1	Size 2	Size 3	Size 4
0-6"	M1.6-M3.5	0.141"	0.110"	19/11-4036			
8, 5/32"	M4	0.168"	0.131"	19/11-4041			
10, 3/16"	M4.5, M5	0.194"	0.152"	19/11-4048			
12, 7/32"		0.220"	0.165"	19/11-4054			
1/4"	M6, M6.3	0.255"	0.191"	19/11-4063			
5/16"	M7, M8	0.318"	0.238"	19/11-4079	31/12-4079		
3/8"	M10	0.381"	0.286"	19/11-4095	31/12-4095		
7/16"	M11	0.323"	0.242"	19/11-4111	31/12-4111		
1/2"	M12, M12.5	0.367"	0.275"	19/11-4127	31/12-4127	48/13-4127	
9/16"	M14	0.429"	0.322"	19/11-4142	31/12-4142	48/13-4142	
5/8"	M16	0.480"	0.360"		31/12-4158	48/13-4158	
11/16"	M18	0.542"	0.406"		31/12-4174	48/13-4174	
3/4"		0.590"	0.442"		31/12-4190C	48/13-4190	
13/16"	M20	0.652"	0.489"		31/12-4206C	48/13-4206	
7/8"	M22	0.697"	0.523"		31/12-4222C	48/13-4222	
15/16"	M24	0.760"	0.570"			48/13-4238	
1"	M25	0.800"	0.600"			48/13-4254	
1 1/8, 1 1/16"	M27	0.896"	0.672"			48/13-4286	
1 1/4, 1 3/16"	M30	1.021"	0.766"			48/13-4317	
1 3/8, 1 5/16"	M33	1.108"	0.831"			48/13-4349	
1 1/2, 1 7/16"	M36	1.233"	0.925"				60/14-4381C
1 5/8"	M39	1.305"	0.979"				60/14-4412C
1 3/4"	M42	1.430"	1.072"				60/14-4444C
1 7/8"		1.520"	1.139"				60/14-4476C
1/8" NPT		0.437"	0.328"	19/11-4097			
1/4" NPT		0.562"	0.421"		31/12-4131C		
3/8" NPT		0.700"	0.531"		31/12-4166C	48/13-4166C	
1/2" NPT		0.687"	0.515"		31/12-4209C	48/13-4209C	
3/4" NPT		0.906"	0.678"			48/13-4264C	
1" NPT		1.125"	0.843"			48/13-4332C	



Tightening Torque Specifications Chart

Recommended Collet & Retention Knob Tightening Torque

Collet	Nut Type	Collets I.D. OVER 1/16" (2mm)	Collets I.D. UNDER 1/16" (2mm)	Order Torque Wrench Adapter
ER16	slotted	42 ft/lbs	30 ft/lbs	04580-16
ER16	hex	42 ft/lbs	30 ft/lbs	04601-16
ER20	slotted	59 ft/lbs	24 ft/lbs	04580-20
ER20	hex	59 ft/lbs	24 ft/lbs	04602-20
ER25	slotted	77 ft/lbs	77 ft/lbs	04503-25
ER25	mini nut	25 ft/lbs	25 ft/lbs	04587
ER32	slotted	100 ft/lbs	100 ft/lbs	04604-32
ER40	slotted	130 ft/lbs	130 ft/lbs	04605-40
SYOZ 25	hook	90 ft/lbs	90 ft/lbs	03690-25
TG 75	slotted	90 ft/lbs	90 ft/lbs	04604-32
TG 100	hook	90 ft/lbs	90 ft/lbs	03690-25

Retention Knobs	Wrench Flats	Drive	Torque	Order Socket
BT30 Taper	0.535"	1/4"	36 ft/lbs	PSS-30BT
ISO 30 Taper	0.535"	3/8"	36 ft/lbs	PSS-30ISO
Any 40 Taper	0.750"	3/8"	76 ft/lbs	PSS-40
BT50 Taper	1.187"	1/2"	99 ft/lbs	PSC-50
CAT50 Taper	1.250"	1/2"	99 ft/lbs	PSC-50

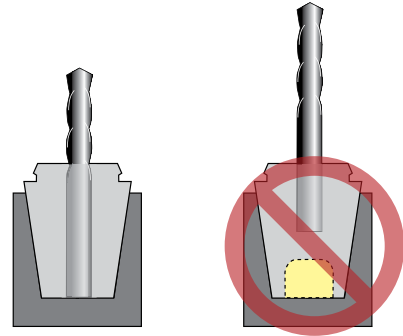

For maximum holding power fill the collet all the way with the tool shank (left) and use a PowerCOAT nut.

DIRECTIONS

1. Snap collet into nut.
2. Insert cutting tool into collet. Make sure shank extends to the bottom of the collet.
3. Hand tighten collet nut assembly into toolholder.
4. Insert toolholder assembly into tightening fixture and secure it.
5. Tighten collet nut to recommended torque using a torque wrench and adapter.

PinzBOHR High Precision Boring Tools

What to expect from our boring tools.

Our European made boring tools have been proven world wide to be among the best you can buy. Machinists love our boring tools because they are easy-to-setup, dead nuts accurate, and stand up to the toughest challenges. We're extremely confident that once you try our boring tools you will become a regular customer.



Techniks Guarantees to either repair or replace the boring head if the head ever fails for any reason (even crashing the head) for as long as you are purchasing and using our high performance inserts.



Pinzbohr Modular Boring Tools
• Range: .314 to 40.157" see page 184

MacroBOHR Large Hole Boring System
Range: 8.661 to 40.157"
see page 217



UltraFINE finish heads



see page 196

BohrSTAR Boring Kits



<http://ow.ly/ring3>
View the video.



see page 172



Built for Speed.

All Techniks products are backed by our 100% satisfaction guarantee!

BohrSTAR High-Performance Kits – .314" to 8.27"

Techniks boring kits for either Triangular or Rhombic inserts

Machinists rely on BohrSTAR kits for performance and ease-of-use (no spacers or complicated set-ups) without the expense of dedicated boring tools.

Features

- Lifetime Guarantee on boring heads
- Dial adjustable 0.0001" increments
- Rhombic or triangular inserts



BohrSTAR43 Kit, Range: 0.314" to 1.69"

Part No.	Description	Page
6991210	BohrSTAR43, rhombic	161
6991215	BohrSTAR43, triangular	162

BohrSTAR100 Kit, Range: 0.314" to 3.94"

Part No.	Description	Page
6991220	BohrSTAR100, rhombic	163
6991235	BohrSTAR100, triangular	164

BohrSTAR170 Kit, Range: 0.314" to 6.69"

Part No.	Description	Page
6991230	BohrSTAR170, rhombic	165
6991250	BohrSTAR170, triangular	166

BohrSTAR210 Kit, Range: 0.314" to 8.27"

Part No.	Description	Page
6991245	BohrSTAR210, rhombic	167
6991240	BohrSTAR210, triangular	168

Triangular kits include:

- 2 Pcs. TCMT 1.2_
- 3 Pcs. TCMT 1.8_
- 2 Pcs. TCMT 32.5_

Rhombic kits include:

- 1 Pc. EPMT 1.5_
- 3 Pcs. CCMT 21.5_
- 3 Pcs. CCMT 32.5_

BohrSTAR210 Kit
8.27"

BohrSTAR170 Kit
6.69"

BohrSTAR100 Kit
3.94"

BohrSTAR43 Kit
1.69"

Choose the kit for the hole size you need



Techniks Guarantees to either repair or replace the boring head if the head ever fails for any reason (even crashing the head) for as long as you are purchasing and using our high-performance inserts.

Kit Setup Examples

Range: from .314" to 8.27"



BohrSTAR 43 Triangular Kit – Range: 0.314 to 1.692"

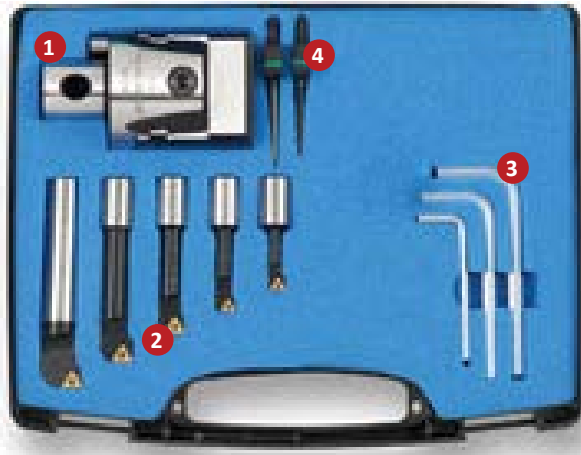

Kit Includes Triangular Inserts:

- 2 Pcs. TCMT 1.21._
- 3 Pcs. TCMT 1.81._



BohrSTAR kits are designed for maximum performance and ease-of-use (no spacers or complicated set-ups). Our boring tools out perform all others when it comes to accuracy, rigidity, and repeatability.

Our exclusive, modular coupling system features two, tapered locking screws that provide maximum rigidity between the boring head and the toolholder to increase accuracy. All connections are easily made using the tools provided.

Kit Part No.	Description	Range
6991215	BS-54-KIT-TC-8-43	0.314" – 1.692"

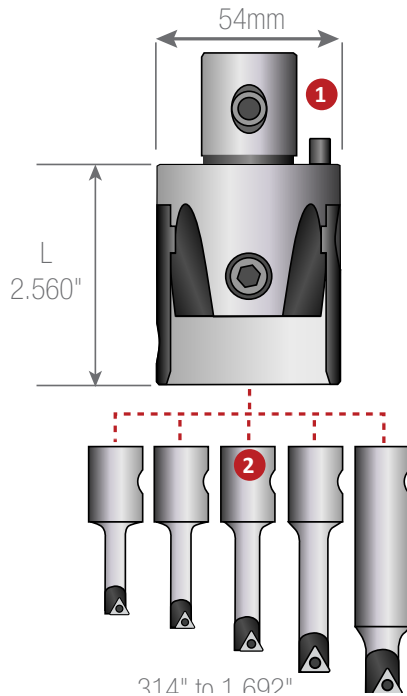

BohrSTAR 43 Kit Includes These Components

Part No.	Description	Length
1 6951234	BS-54-16-W head	2.560"
6943333	BS-06-16-T01 6mm bar	.984"
6943334	BS-08-16-T01 8mm bar	1.378"
2 6943335	BS-10-16-T02 10mm bar	1.772"
6943336	BS-12-16-T02 12mm bar	2.244"
6943337	BS-16-16-T02 16mm bar	2.874"
6962233	H3 hex	-
3 6962235	H5 hex	-
6962236	H6 hex	-
6972236	T6 torx	-
4 6972237	T7 torx	-

Kit Boring Bar & Insert Specifications

Part No.	Boring Bar Description	Bore Range		L	Insert	Insert Screw	Wrench
		Min	Max				
6943333	BS-06-16-T01	.314"	1.181"	.984"	TCMT 1.21._	6811220	9355111
6943334	BS-08-16-T01	.394"	1.260"	1.378"	TCMT 1.21._	6811235	9355111
6943335	BS-10-16-T02	.512"	1.378"	1.772"	TCMT 1.81.5_	6811250	9355222
6943336	BS-12-16-T02	.630"	1.496"	2.244"	TCMT 1.81.5_	6811250	9355222
6943337	BS-16-16-T02	.787"	1.692"	2.874"	TCMT 1.81.5_	6811250	9355222



BohrSTAR 43 Rhombic Kit – Range: .314 to 1.692"

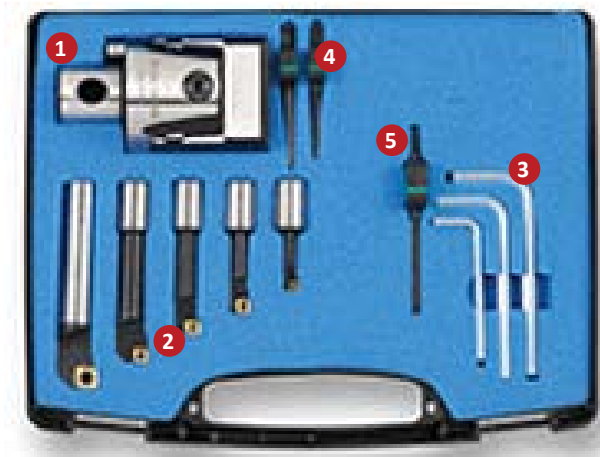

Kit Includes Rhombic Inserts:

- 1 Pc. EPMT 1.5_
- 3 Pcs. CCMT 21.5_
- 1 Pc. CCMT 32.5_



CCMT

BohrSTAR kits are designed for maximum performance and ease-of-use (no spacers or complicated set-ups). Our boring tools out perform all others when it comes to accuracy, rigidity, and repeatability.

Our exclusive, modular coupling system features two, tapered locking screws that provide maximum rigidity between the boring head and the toolholder to increase accuracy. All connections are easily made using the tools provided.

Kit Part No.	Description	Range
6991210	BS-54-KIT-RC-8-43	0.314" – 1.692"

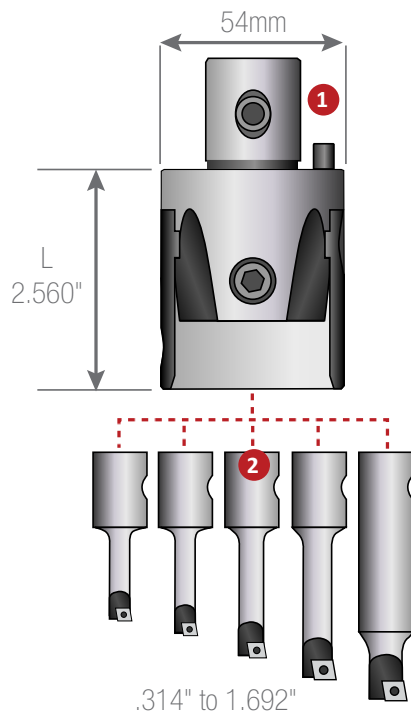

BohrSTAR 43 Kit Includes These Components

Part No.	Description	Length
① 6951234	BS-54-16-W head	2.560"
6942234	BS-06-16-R02 6mm bar	.984"
6942235	BS-08-16-R03 8mm bar	1.378"
② 6942236	BS-10-16-R03 10mm bar	1.772"
6942237	BS-12-16-R03 12mm bar	2.244"
6942238	BS-16-16-R04 16mm bar	2.874"
6962233	H3 hex	-
③ 6962235	H5 hex	-
6962236	H6 hex	-
④ 6972238	T8 torx	-
6972237	T7 torx	-
⑤ 6972215	T15 torx	-

Kit Boring Bar & Insert Specifications

Part No.	Description	Bore Range			L	Insert	Insert Screw	Wrench
		Min	Max					
6942234	BS-06-16-R02	.314"	1.181"	.984"	EPMT 1.53_	6811220	9355222	
6942235	BS-08-16-R03	.394"	1.260"	1.378"	CCMT 21.5_	6811235	9355333	
6942236	BS-10-16-R03	.512"	1.378"	1.772"	CCMT 21.5_	6811250	9355333	
6942237	BS-12-16-R03	.630"	1.496"	2.244"	CCMT 21.5_	6811250	9355333	
6942238	BS-16-16-R04	.787"	1.692"	2.874"	CCMT 32.5_	6811260	9355555	

BohrSTAR 100 Triangular Kit – Range: 0.314 to 3.94"



Kit Includes Triangular Inserts:

- 2 Pcs. TCMT 1.21._
- 3 Pcs. TCMT 1.81._
- 2 Pcs. TCMT 32.5_



BohrSTAR kits are designed for maximum performance and ease-of-use (no spacers or complicated set-ups). Our boring tools out perform all others when it comes to accuracy, rigidity, and repeatability.

Our exclusive, modular coupling system features two, tapered locking screws that provide maximum rigidity between the boring head and the toolholder to increase accuracy. All connections are easily made using the tools provided.

Kit Part No.	Description	Range
6991235	BS-54-KIT-TC-8-100	0.314" – 3.94"

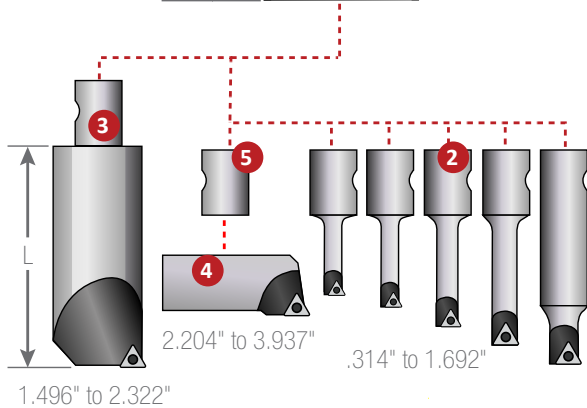
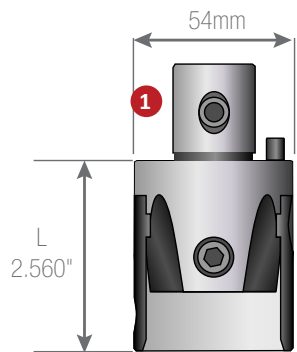

BohrSTAR 100 Kit Includes These Components

Part No.	Description	Length
1	6951234 BS-54-16-W head	2.560"
	6943333 BS-06-16-T01 6mm bar	.984"
	6943334 BS-08-16-T01 8mm bar	1.378"
2	6943335 BS-10-16-T02 10mm bar	1.772"
	6943336 BS-12-16-T02 12mm bar	2.244"
	6943337 BS-16-16-T02 16mm bar	2.874"
3	6943338 BS-34-16-T04 34mm bar	3.228"
4	6922243 BS-2CT-T04 cartridge	
5	6921239 BS-16-M10 location sleeve	
	6962233 H3 hex	
	6962235 H5 hex	
6	6962236 H6 hex	
	6962238 H8 hex	
	6972236 T6 torx	
7	6972237 T7 torx	
	6972215 T15 torx	
8	6921241 CS-10-25 cartridge screw	

Kit Boring Bar & Insert Specifications

Part No.	Description	Bore Range		L	Insert	Insert Screw	Wrench
		Min	Max				
6943333	BS-06-16-T01	.314"	1.181"	.984"	TCMT 1.21._	6811220	9355111
6943334	BS-08-16-T01	.394"	1.260"	1.378"	TCMT 1.21._	6811235	9355111
6943335	BS-10-16-T02	.512"	1.378"	1.772"	TCMT 1.81.5_	6811250	9355222
6943336	BS-12-16-T02	.630"	1.496"	2.244"	TCMT 1.81.5_	6811250	9355222
6943337	BS-16-16-T02	.787"	1.692"	2.874"	TCMT 1.81.5_	6811250	9355222
6943338	BS-34-16-T04	1.496"	2.322"	3.228"	TCMT 32.5_	6811260	9355555
6922243	BS-2CT-T04 cartridge	2.204"	3.937"	.787"	TCMT 32.5_	6811260	9355555



BohrSTAR 100 Rhombic Kit – Range: 0.314 to 3.94"



Kit Includes Rhombic Inserts:

- 1 Pc. EPMT 1.5_
- 3 Pcs. CCMT 21.5_
- 3 Pcs. CCMT 32.5_

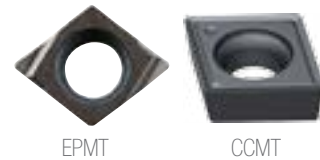

BohrSTAR kits are designed for maximum performance and ease-of-use (no spacers or complicated set-ups). Our boring tools out perform all others when it comes to accuracy, rigidity, and repeatability.

Our exclusive, modular coupling system features two, tapered locking screws that provide maximum rigidity between the boring head and the toolholder to increase accuracy. All connections are easily made using the tools provided.

Kit Part No.	Description	Range
6991220	BS-54-KIT-RC-8-100	0.314" – 3.94"

BohrSTAR 100 Kit Includes These Components

Part No.	Description	Length
1 6951234	BS-54-16-W Head	2.560"
6942234	BS-06-16-R02 6mm bar	.984"
6942235	BS-08-16-R03 8mm bar	1.378"
2 6942236	BS-10-16-R03 10mm bar	1.772"
6942237	BS-12-16-R03 12mm bar	2.244"
6942238	BS-16-16-R04 16mm bar	2.874"
3 6942239	BS-34-16-R04 34mm bar	3.228"
4 6922243	BS-2CT-R04 Cartridge	
5 6921239	BS-16-M10 Location sleeve	
6962233	H3 Hex	
6 6962235	H5 Hex	
6962236	H6 Hex	
6962238	H8 Hex	
6972238	T8 Torx	
7 6972237	T7 Torx	
6972215	T15 Torx	
8 6921241	CS-10-25 Cartridge screw	

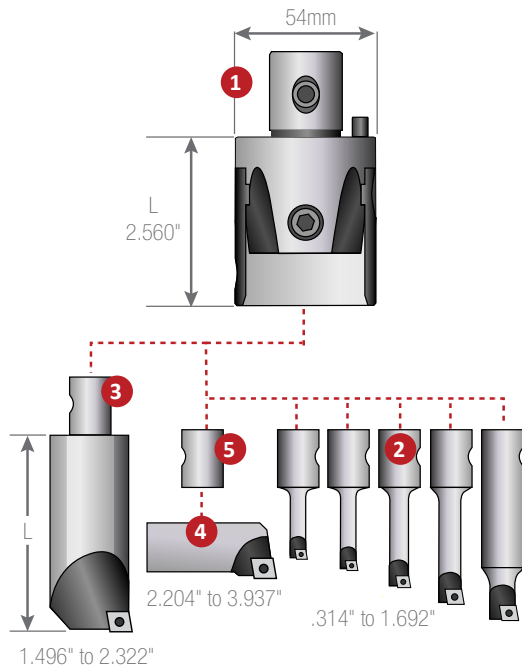

Kit Boring Bar & Insert Specifications

Part No.	Description	Bore Range		L	Insert	Insert Screw	Wrench
		Min	Max				
6942234	BS-06-16-R02	.314"	1.181"	.984"	EPMT 1.53_	6811220	9355222
6942235	BS-08-16-R03	.394"	1.260"	1.378"	CCMT 21.5_	6811235	9355333
6942236	BS-10-16-R03	.512"	1.378"	1.772"	CCMT 21.5_	6811250	9355333
6942237	BS-12-16-R03	.630"	1.496"	2.244"	CCMT 21.5_	6811250	9355333
6942238	BS-16-16-R04	.787"	1.692"	2.874"	CCMT 32.5_	6811260	9355555
6942239	BS-34-16-R04	1.496"	2.322"	3.228"	CCMT 32.5_	6811260	9355555
6922243	BS-2CT-R04 Cartridge	2.204"	3.937"	.787"	CCMT 32.5_	6811260	9355555

BohrSTAR 170 Triangular Kit – Range: .314 to 6.69"

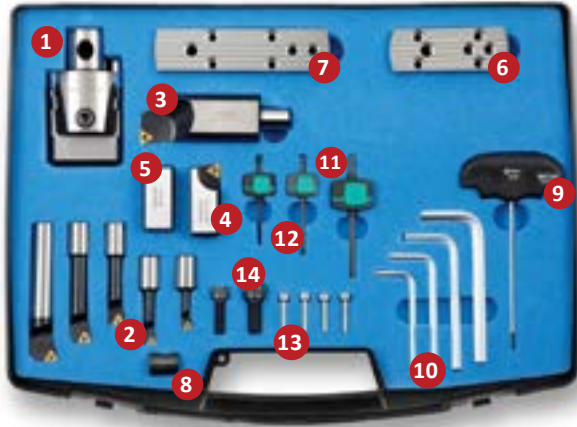

Kit Includes Triangular Inserts:

- 2 Pc. TCMT 1.21._
- 3 Pcs. TCMT 1.81._
- 2 Pcs. TCMT 32.5_



TCMT

Kit Part No.	Description	Range
6991250	BS-54-KIT-TC-8-170	0.314" – 6.69"

BohrSTAR 170 Kit Includes These Components

Part No.	Description	Length
1 6951234	BS-54-16-W Head	2.560"
6943333	BS-06-16-T01 6mm Bar	.984"
6943334	BS-08-16-T01 8mm Bar	1.378"
2 6943335	BS-10-16-T02 10mm Bar	1.772"
6943336	BS-12-16-T02 12mm Bar	2.244"
6943337	BS-16-16-T02 16mm Bar	2.874"
3 6943338	BS-34-16-T04 34mm Bar	3.228"
4 6922243	BS-2CT-T04 Cartridge	.787"
5 6921235	BS-2CW Counterweight	.728"
6 6921236	BS-SP-85-130 Small plate	.787"
7 6921237	BS-SP-125-170 Medium plate	.787"
8 6921239	BS-16-M10 Location sleeve	

Part No.	Description
9 6921243	A3 Adjusting key
6962234	H4 Hex
6962235	H5 Hex
10 6962236	H6 Hex
6962238	H8 Hex
6972237	T7 Torx
11 6972238	T8 Torx
6972215	T15 Torx
12 6921240	D-27-21 Plate fixing screws
13 6921241	CS-10-25 Cartridge screw
14 6921242	CS-08-25 Counterweight screw

Kit Boring Bar & Insert Specifications

Part No.	Description	Bore Range			Insert	Insert Screw	Wrench
		Min	Max	L			
6943333	BS-06-16-T01	.314"	1.181"	.984"	TCMT 1.21._	6811220	T6
6943334	BS-08-16-T01	.394"	1.260"	1.378"	TCMT 1.21._	6811235	T6
6943335	BS-10-16-T02	.512"	1.378"	1.772"	TCMT 1.81.5_	6811250	T7
6943336	BS-12-16-T02	.630"	1.496"	2.244"	TCMT 1.81.5_	6811250	T7
6943337	BS-16-16-T02	.787"	1.692"	2.874"	TCMT 1.81.5_	6811250	T7
6943338	BS-34-16-T04	1.496"	2.322"	3.228"	TCMT 32.5_	6811260	T15
6922243	BS-2CT-T04 cartridge	2.204"	3.937"	.787"	TCMT 32.5_	6811260	T15

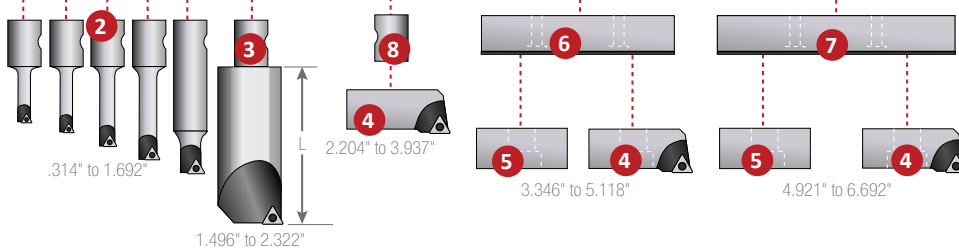
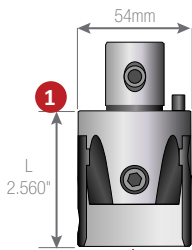

BohrSTAR 170 Rhombic Kit – Range: 0.314 to 6.69"

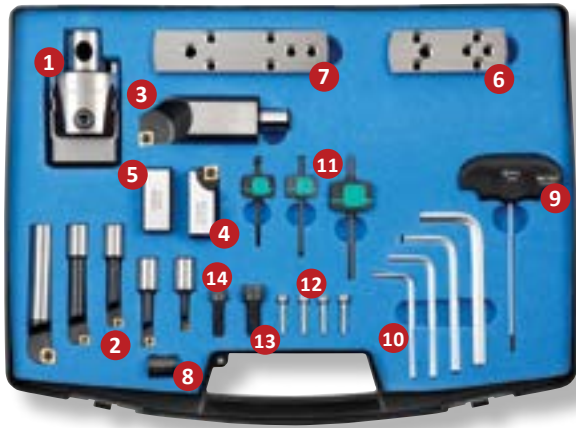

Kit Includes Rhombic Inserts:

- 1 Pc. EPMT 1.5_
- 3 Pcs. CCMT 21.5_
- 3 Pcs. CCMT 32.5_

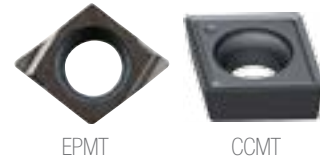

Kit Part No.	Description	Range
6991230	BS-54-KIT-RC-8-170	0.314" – 6.69"

NOTE: For a triangular insert version of this kit, range: 0.314 – 6.692" order: Part No. 6991250.

BohrSTAR 170 Kit Includes These Components

Part No.	Description	Length
1	6951234 BS-54-16-W head	2.560"
	6942234 BS-06-16-R02 6mm bar	.984"
	6942235 BS-08-16-R03 8mm bar	1.378"
2	6942236 BS-10-16-R03 10mm bar	1.772"
	6942237 BS-12-16-R03 12mm bar	2.244"
	6942238 BS-16-16-R04 16mm bar	2.874"
3	6942239 BS-34-16-R04 34mm bar	3.228"
4	6921234 BS-2CT-R04 cartridge	.787"
5	6921235 BS-2CW counterweight	.728"
6	6921236 BS-SP-85-130 small plate	.787"
7	6921237 BS-SP-123-170 medium plate	.787"
8	6921239 BS-16-M10 location sleeve	-

Part No.	Description
9	6921243 A3 adjusting key
	6962234 H4 hex
10	6962235 H5 hex
	6962236 H6 hex
	6962238 H8 hex
	6972237 T7 torx
11	6972238 T8 torx
	6972215 T15 torx
12	6921240 D-27-21 plate fixing screws
13	6921241 CS-10-25 cartridge screw
14	6921242 CS-08-25 counterweight screw

Kit Boring Bar & Insert Specifications

Bore Range

Part No.	Description	Min	Max	L	Insert	Insert Screw	Wrench
6942234	BS-06-16-R02	.314"	1.181"	.984"	EPMT 1.53_	6811220	9355222
6942235	BS-08-16-R03	.394"	1.260"	1.378"	CCMT 21.5_	6811235	9355333
6942236	BS-10-16-R03	.512"	1.378"	1.772"	CCMT 21.5_	6811250	9355333
6942237	BS-12-16-R03	.630"	1.496"	2.244"	CCMT 21.5_	6811250	9355333
6942238	BS-16-16-R04	.787"	1.692"	2.874"	CCMT 32.5_	6811260	9355555
6942239	BS-34-16-R04	1.496"	2.322"	3.228"	CCMT 32.5_	6811260	9355555
6921234	BS-2CT-R04 cartridge	2.204"	3.937"	.787"	CCMT 32.5_	6811260	9355555

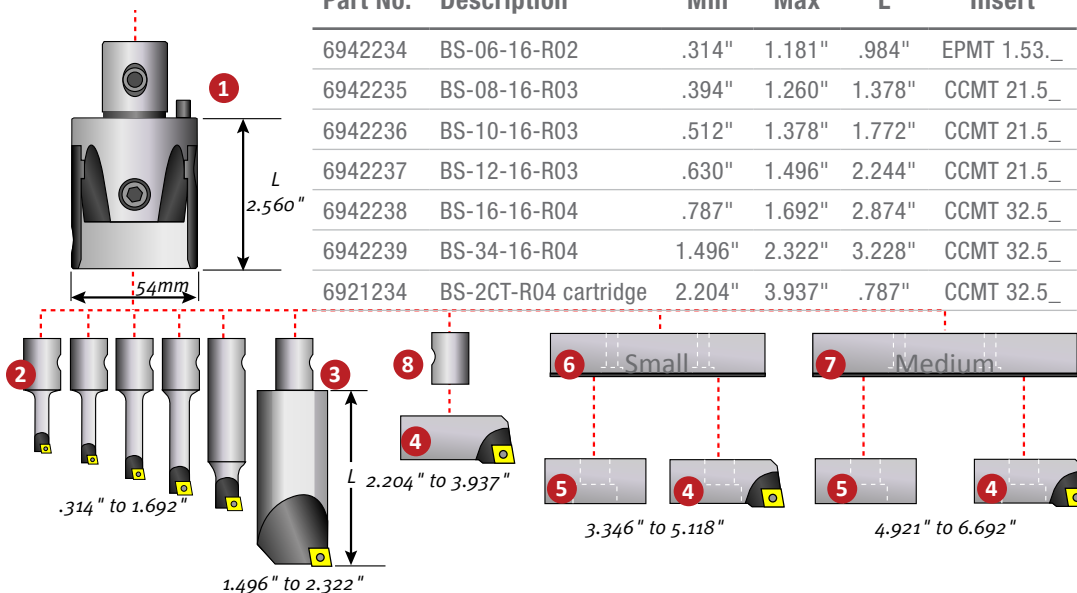

BohrSTAR 210 Triangular Kit – Range: 0.314 to 8.27"



Kit Includes Triangular Inserts:

- 2 Pcs. TCMT 1.21_
- 3 Pcs. TCMT 1.81_
- 2 Pcs. TCMT 32.5_



TCMT

BohrSTAR kits are designed for maximum performance and ease-of-use (no spacers or complicated set-ups). Our boring tools out perform all others when it comes to accuracy, rigidity, and repeatability.

BohrSTAR 210 Kit Includes These Components

Part No.	Description	Length
1 6951234	BS-54-16-W head	2.560"
6943333	BS-06-16-T01 6mm bar	.984"
6943334	BS-08-16-T01 8mm bar	1.378"
2 6943335	BS-10-16-T02 10mm bar	1.772"
6943336	BS-12-16-T02 12mm bar	2.244"
6943337	BS-16-16-T02 16mm bar	2.874"
3 6943338	BS-34-16-T04 34mm bar	3.228"
4 6922243	BS-2CT-T04 cartridge	.787"
5 6921235	BS-2CW counterweight	.728"
6 6921236	BS-SP-85-130 small plate	.787"
7 6921237	BS-SP-123-170 medium plate	.787"
8 6921238	BS-SP-165-210 large plate	.787"

Kit Part No.	Description	Range
6991240	BS-54-KIT-TC-8-210	0.314" – 8.27"

NOTE: For a rhombic insert version of this kit, order: Part No. 6991245.

Part No.	Description
9 6921239	BS-16-M10 location sleeve
10 6921243	A3 adjusting key
6962234	H4 hex
11 6962235	H5 hex
6962236	H6 hex
6962238	H8 hex
6972236	T6 torx
12 6972237	T7 torx
6972215	T15 torx
13 6921240	D-27-21 plate fixing screws
14 6921241	CS-10-25 cartridge screw
15 6921242	CS-08-25 counterweight screw

Kit Boring Bar & Insert Specifications

Part No.	Description	Bore Range			Insert	Insert Screw	Wrench
		Min	Max	L			
6943333	BS-06-16-T01	.314"	1.181"	.984"	TCMT 1.21_	6811220	9355111
6943334	BS-08-16-T01	.394"	1.260"	1.378"	TCMT 1.21_	6811235	9355111
6943335	BS-10-16-T02	.512"	1.378"	1.772"	TCMT 1.81.5_	6811250	9355222
6943336	BS-12-16-T02	.630"	1.496"	2.244"	TCMT 1.81.5_	6811250	9355222
6943337	BS-16-16-T02	.787"	1.692"	2.874"	TCMT 1.81.5_	6811260	9355222
6943338	BS-34-16-T04	1.496"	2.322"	3.228"	TCMT 32.5_	6811260	9355555
6922243	BS-2CT-T04 cartridge	2.204"	3.937"	.787"	CCMT 32.5_	6811260	9355555



BohrSTAR 210 Rhombic Kit – Range: 0.317 to 8.27"

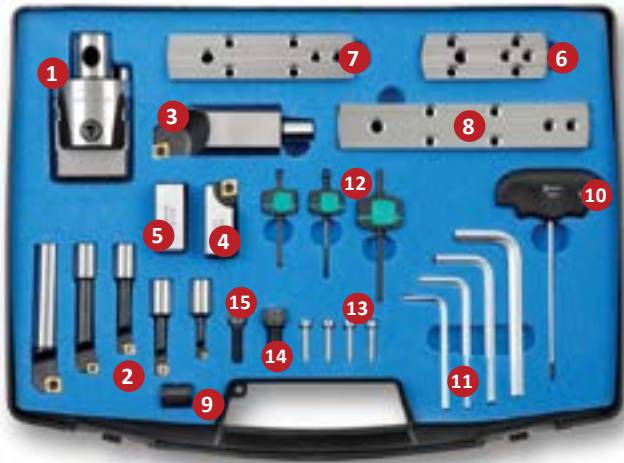

Kit Includes Rhombic Inserts:

- 1 Pc. EPMT 1.5_
- 3 Pcs. CCMT 21.5_
- 3 Pcs. CCMT 32.5_

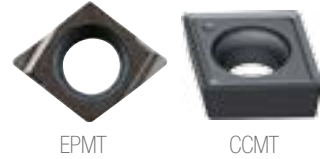

Kit Part No.	Description	Range
6991245	BS-54-KIT-RC-8-210	0.314" – 8.27"

BohrSTAR 210 Kit Includes These Components

Part No.	Description	Length
1 6951234	BS-54-16-W Head	2.560"
6942234	BS-06-16-R02 6mm bar	.984"
6942235	BS-08-16-R03 8mm bar	1.378"
2 6942236	BS-10-16-R03 10mm bar	1.772"
6942237	BS-12-16-R03 12mm bar	2.244"
6942238	BS-16-16-R04 16mm bar	2.874"
3 6942239	BS-34-16-R04 34mm bar	3.228"
4 6921234	BS-2CT-R04 Cartridge	.787"
5 6921235	BS-2CW Counterweight	.728"
6 6921236	BS-SP-85-130 Small plate	.787"
7 6921237	BS-SP-125-170 Medium plate	.787"
8 6921238	BS-SP-165-210 Large plate	.787"

Part No.	Description
9 6921239	BS-16-M10 Location sleeve
10 6921243	A3 Adjusting key
6962234	H4 Hex
6962235	H5 Hex
11 6962236	H6 Hex
6962238	H8 Hex
6972238	T8 Torx
12 6972237	T7 Torx
6972215	T15 Torx
13 6921240	D-27-21 Plate fixing screws
14 6921241	CS-10-25 Cartridge screw
15 6921242	CS-08-25 Counterweight screw

Kit Boring Bar & Insert Specifications

Part No.	Description	Bore Range			Insert	Insert Screw	Wrench
		Min	Max	L			
6942234	BS-06-16-R02	.314"	1.181"	.984"	EPMT 1.53_	6811220	T7
6942235	BS-08-16-R03	.394"	1.260"	1.378"	CCMT 21.5_	6811235	T8
6942236	BS-10-16-R03	.512"	1.378"	1.772"	CCMT 21.5_	6811250	T8
6942237	BS-12-16-R03	.630"	1.496"	2.244"	CCMT 21.5_	6811250	T8
6942238	BS-16-16-R04	.787"	1.692"	2.874"	CCMT 32.5_	6811260	T15
6942239	BS-34-16-R04	1.496"	2.322"	3.228"	CCMT 32.5_	6811260	T15
6921234	BS-2CT-R04 Cartridge	2.204"	3.937"	.787"	CCMT 32.5_	6811260	T15

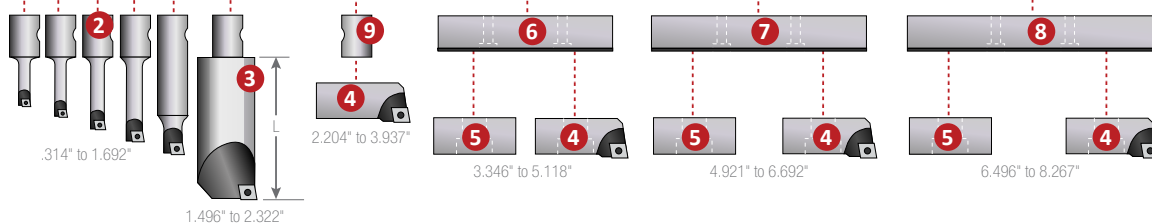
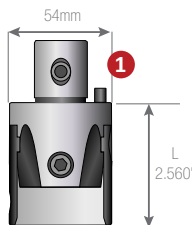

Toolholders and Inserts for BohrSTAR Kits

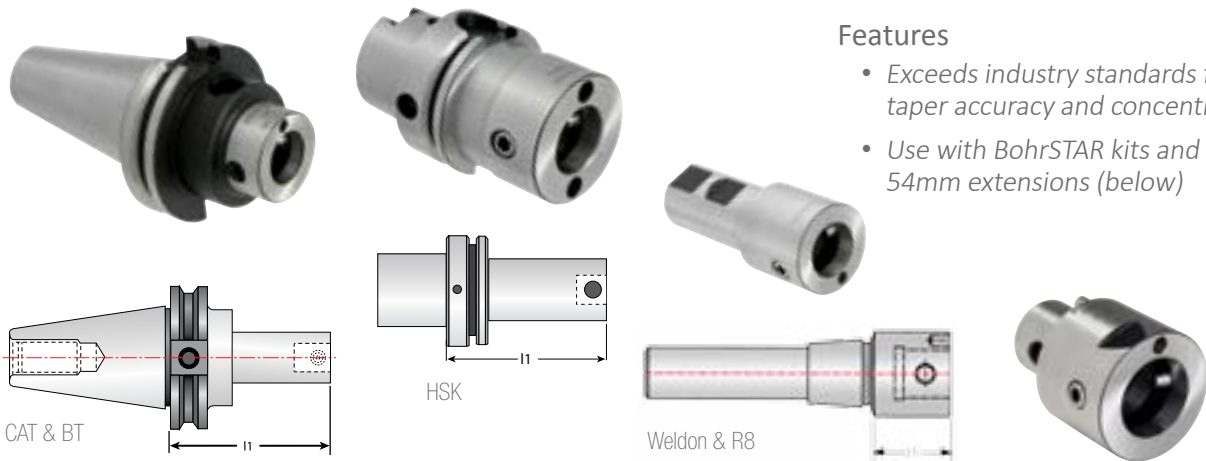

Features

- Exceeds industry standards for taper accuracy and concentricity
- Use with BohrSTAR kits and 54mm extensions (below)

CAT40, CAT50 BT40 Toolholders

Part No.	Spindle	Description	I1
6134310	CAT40	CT-340-54-120	3.00"
6134315	CAT40	CT-340-54-160	4.57"
6134320	CAT40	CT-340-54-200	6.14"
6141305	CAT50	CT-350-54-90	2.44"
6141310	CAT50	CT-350-54-160	5.20"
6141315	CAT50	CT-350-54-200	6.77"
6140400	BT40	BT-340-54-90	2.13"
6140425	BT40	BT-340-54-160	4.88"
6140450	BT40	BT-340-54-200	6.46"

Toolholders come with coupling screw installed. Order 6811550 for replacements.

BT50, HSK, Weldon, R8 Toolholders

Part No.	Spindle	Description	I1
6150375	BT50	BT-350-54-90	2.56"
6150400	BT50	BT-350-54-160	5.31"
6150425	BT50	BT-350-54-200	6.90"
6155635	HSK63	HSK-63A-54-110	2.76"
6155105	HSK100	HSK-100A-54-110	2.76"
6165343	Weldon	B-20-54-110-3/4	0.75"
6165103	Weldon	B-25-54-110-1.0	1.00"
6165144	Weldon	B-32-54-110-1-1/4	1.25"
6165123	Weldon	B-40-54-110-1-1/2	1.50"
6165805	R8	R8-54-110	1.50"

Extensions

Pt. No.	Desc.	L
6555450	P-54-50	1.97"
6555475	P-54-75	2.95"

The coolant-thru spindle extension directs coolant to the cutting zone for optimal stock removal rates.

Coolant Extension

Pt. No.	Desc.	L
6565450	P-54-50R	1.97"

Stock up on high-performance LT1000 PVD Inserts for BohrSTAR Kits!

Features

- LT1000 PVD is 14 microns thick! (3.5x thicker)
- 250% longer insert life
- Great for exotics and stainless

We recommend LT1000 or LT10 grade inserts for best performance and extended insert life.



Triangular Inserts for Kits

Part No.	Description	Grade
3533010	TCMT 1.2(1).50	5615
3533020	TCMT 1.2(1)1	5625
3563311	TCMT 1.8(1.5)0 HF	251
3533033	TCMT 1.8(1.5)1 HM	251
3563388	TCMT 1.8(1.5)2 HM	251
3563399	TCMT 1.8(1.5)1 HF	251
3533030	TCMT 1.8(1.5)1 PF4	5625
3564438	TCMT 3(2.5)1 NN	LT 10
3568851	TCMT 3(2.5)1 NN	LT 1000
3564441	TCMT 3(2.5)2 NN	LT 10
3568861	TCMT 3(2.5)2 NN	LT 1000

Rhombic Inserts for Kits

Part No.	Description	Grade
3663311	CCMT 2(1.5)0 HF	251
3664411	CCMT 2(1.5)1 NN	LT 10
3668011	CCMT 2(1.5)1 NN	LT 1000
3663399	CCMT 2(1.5)2 HM	251
3663344	CCMT 3(2.5)0 HF	251
3664413	CCMT 3(2.5)1 NN	LT 10
3668021	CCMT 3(2.5)1 NN	LT 1000
3664416	CCMT 3(2.5)2 NN	LT 10
3668026	CCMT 3(2.5)2 NN	LT 1000
3934030	EPMT 1.5(3).5 PM5	5625

PinzBOHR High Precision Modular Boring Tools

PinzBOHR Modular System

PinzBOHR is a flexible boring system for holes ranging from 0.315" up to 40.157". The system includes all necessary extensions and reducers, rough heads, finish heads and even includes face mill arbors and end mill holder options.



Carbide & HSS Boring Bars



Boring Heads .945" 19.685"



MacroBOHR range: 8.661 – 40.157"

Toolholders for CAT, BT, HSK and more!



Extensions & Reducers

modular toolholders

Boring Head Lifetime Warranty

We will either replace or repair the head if it fails for ANY reason, (even crashing the spindle) for as long as you own the head and are using our high-performance inserts.

We're known for customer satisfaction.

All our tools are backed with full factory technical support and our 100% Satisfaction Warranty. Lifetime Guarantee applies to all sizes and types of boring heads including BohrSTAR kits.



[Boring Kits](#)



[Rough Heads](#)



[Finish Heads](#)



[MacroBOHR](#)

PinzBOHR Design Provides Best Rigidity & Accuracy

We put more metal behind the insert for maximum rigidity and accuracy!

All PinzBOHR heads feature insert pockets that are either integral with the body of the head, or feature integral cartridges to provide maximum rigidity and accuracy.

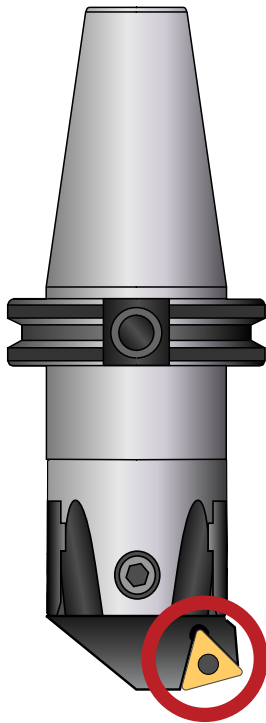

- Simple and extremely strong design for best reliability, rigidity, and repeatability.
- Flexible, modular system reduces tooling inventory.
- Top quality steel alloy hardened to 58-60 HRC.
- Heads are heat treated to minimize wear.
- Precision ground components for highest accuracy.

PinzBOHR designs the insert pocket integral with the head for maximum strength, rigidity, and insert life.

Other Brands

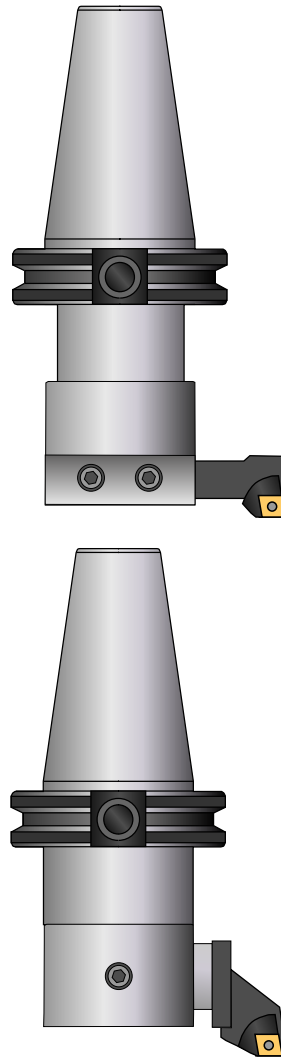

Other Design #1

Bar extension design is an unbalanced, weak solution, extending from the side of the head. Extension is subject to runout during cutting, reducing accuracy and shortening insert life.

PinzBOHR design puts the pocket and insert in the head. This maximizes rigidity and accuracy.

Other Design #2

Dogleg variation is better than above, but also extends beyond the body of the boring head, causing runout.

Modular Coupling System

Allows heads to be changed quickly without removing tools from the spindle. Two offset center lock screws apply maximum tightening force between the boring head and the toolholder.

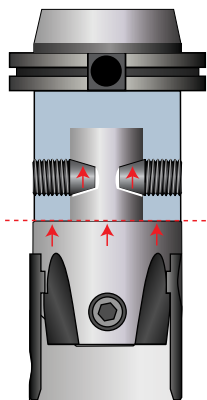

Ease-of-Use Features

- SafetySET feature prevents damage to the adjustment screw.

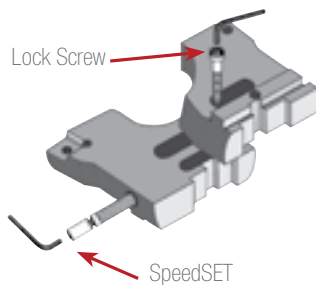

- SpeedSET synchronized adjustment for setting of roughing heads.

Adjustment is This Easy

- AccuSET graduated dial for fast and easy cutting adjustments in .0001" increments.



- .0001" graduated dial allows operators to quickly set the head to any cutting diameter.

PinzBOHR Modular Boring Tools – Range: .315 to 40.157"

Pinzbohr Modular Boring tools feature range from .315 to 19.685".

For boring holes from 8.661 up to 40.157" see our MacroBOHR boring tools on page 204.



Boring Bars – Use with Micro Head A-42-016



Features

- 16mm shanks for A-42-016 micro head
- Manufactured from HSS or Carbide
- Precision ground shank



Inserts & Cartridges
pg. 199



Toolholders
pg. 203



Extensions & Reducers
pg. 213



Retention Knobs
pg. 228

5:1 length-to-diameter ratios can be achieved when roughing with steel bars. 3:1 length-to-diameter ratios can be achieved when finishing with steel bars.

The shortest bar overhang possible should be used to maximize results.

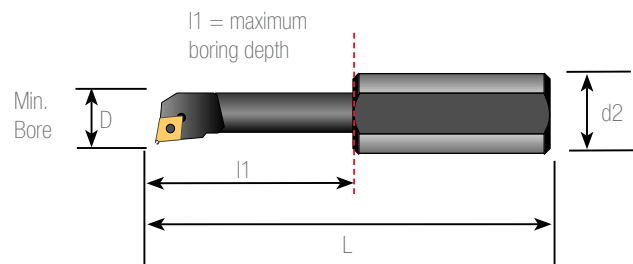

HSS Boring Bars for Micro Head A-42-016

Part No.	Description	D Min. Bore	d2 (mm)	L	(l1)	Insert	Screw	Wrench
6711225	S06-16SELPR-04	.315"	16	2.598"	.984"	EPGT 1.21._L	6811210	9355111
6711235	S06-16SELPR-05	.315"	16	2.598"	.984"	EPMT 1.53._	6811220	9355111
6722225	S06-16STFCR-06	.315"	16	2.598"	.984"	TCMT 1.21._	6811215	9355111
6711245	S08-16SCLCR-06	.394"	16	2.992"	1.377"	CCMT 21.5._	6811235	9355222
6722235	S08-16STFCR-06	.394"	16	2.992"	1.377"	TCMT 1.21._	6811215	9355111
6711255	S10-16SCLCR-06	.512"	16	3.386"	1.771"	CCMT 21.5._	6811250	9355222
6722245	S10-16STFCR-09	.512"	16	3.386"	1.771"	TCMT 1.81.5._	6811230	9355222
6711265	S12-16SCLCR-06	.630"	16	3.858"	2.244"	CCMT 21.5._	6811255	9355222
6722255	S12-16STFCR-09	.630"	16	3.858"	2.244"	TCMT 1.81.5._	6811230	9355222
6711275	S16-16SCLCR-09	.787"	16	4.488"	2.874"	CCMT 32.5._	6811260	9355555
6722265	S16-16STFCR-09	.787"	16	4.488"	2.874"	TCMT 1.81.5._	6811230	9355222
6722275	S16-16STFCR-16	.787"	16	4.488"	2.874"	TCMT 32.5._	6811260	9355555

Carbide Boring Bar for Micro Head A-42-016

Part No.	Description	D Min. Bore	d2 (mm)	L	(l1)	Insert	Screw	Wrench
6733265	C16L-SCLCR-09	.787"	16	5.512"	4.409"	CCMT 32.5._	6811260	T15

Boring Bars – Carbide or HSS Shank



Features

- Minimum bore .315"
- Maximum bore 1.496"
- Carbide or HSS

Usage

- 7:1 length-to-diameter ratios can be achieved with carbide bars
- 5:1 for roughing with steel bars
- 3:1 for finishing with steel bars

Select a boring bar with a "d2" dimension that matches the "d2" of the head.

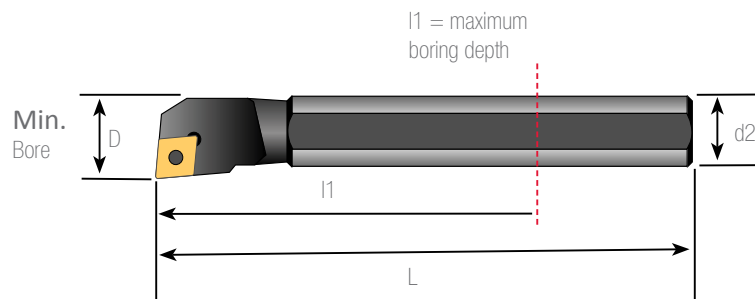

Carbide Shank Boring Bars

Part No.	Description	Micro Head	Min. Bore	d2	L	(l1)	Insert	Screw	Wrench
6733225	C06F-SELPR-04	A-27-006	.315"	6mm	3.150"	2.204"	EPGT1.21._L	6811210	T6
6733230	C06-08H-SELPR-05	A-27-008 or A-32-008	.315"	8mm	3.150"	2.204"	EMPT1.53._	6811210	T6
6733235	C08G-SCLCR-06	A-27-008 or A-32-008	.394"	8mm	3.543"	2.362"	CCMT21.5_	6811235	T7
6733245	C10J-SCLCR-06	A-32-010 or A-42-010	.512"	10mm	4.331"	2.913"	CCMT21.5_	6811250	T7
6733255	C12K-SCLCR-06	A-42-012	.630"	12mm	4.921"	3.503"	CCMT21.5_	6811255	T7
6733265	C16L-SCLCR-09	A-42-016	.787"	16mm	5.512"	4.094"	CCMT32.5_	6811260	T15

HSS Shank Boring Bars

Part No.	Description	Micro Head	Min. Bore	d2	L	(l1)	Insert	Screw	Wrench
6733227	S06E-SELPR-04	A-27-006	.315"	6mm	2.756"	1.811"	EPGT1.21._L	6811210	T6
6733232	S06E-SELPR-05	A-27-006	.315"	6mm	2.756"	1.811"	EMPT1.53._	6811210	T6
6733237	S08F-SCLCR-06	A-27-008 & A32-008	.394"	8mm	3.150"	1.968"	CCMT21.5_	6811235	T7
6733247	S10G-SCLCR-06	A-32-010 & A42-010	.512"	10mm	3.543"	2.125"	CCMT21.5_	6811250	T7
6733257	S12H-SCLCR-06	A-42-012	.630"	12mm	3.937"	2.519"	CCMT21.5_	6811255	T7
6733267	S16J-SCLCR-09	A-42-016	.787"	16mm	4.331"	2.913"	CCMT32.5_	6811260	T15

Micro Heads for Carbide or HSS Boring Bars



Features

- AccuSET .0001" graduated dial allows fast and easy adjustments
- Tapered nose improves clearance
- Two offset center lock screws maximize rigidity while still permitting fast tool changes



Inserts & Cartridges
pg. 199



Toolholders
pg. 203



Extensions & Reducers
pg. 213



Retention Knobs
pg. 228

Micro Heads available in five shank sizes for carbide and HSS boring bars.

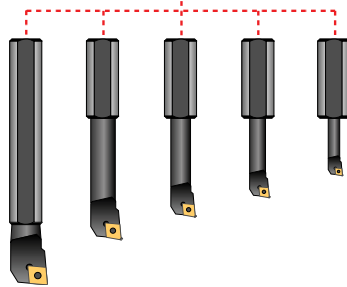

Adjustment Is This Easy

AccuSET graduated adjustment dial



Adjustable in 0.0001" increments

Metric dials available

.0001" dial allows operators to quickly set the finish head to any diameter.

Procedure:

1. Loosen locking screw
2. Remove any backlash
3. Rotate scale to desired setting
4. Tighten locking screw

Select a micro head with a "d2" dimension that matches the "d2" of the boring bar. (see page 166)

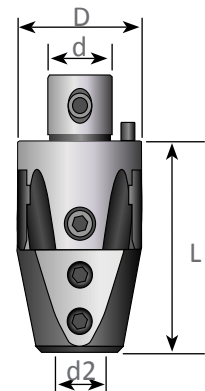

AccuSET Micro Heads

Part No.	Description	Range		D (mm)	d (mm)	d2 (mm)	L
		Min	Max				
6011000	A-27-006	.315"	.787"	27	15	6	1.97"
6011050	A-27-008	.394"	.827"	27	15	8	1.97"
6011100	A-32-008	.394"	.827"	32	18	8	2.28"
6011150	A-32-010	.512"	.984"	32	18	10	2.28"
6011200	A-42-010	.512"	1.142"	42	24	10	2.76"
6011250	A-42-012	.63"	1.339"	42	24	12	2.76"
6011300	A-42-016	.787"	1.496"	42	24	16	2.76"

Note: All wrenches are included with each boring head. No special tools are needed.



75° Lead Angle Rough Heads – Range: .945 to 8.661"



Integral pocket type

Features

- SpeedSET feature adjusts both slides at once and slides won't lose position during adjustment
- SafetySET feature prevents accidental damage to adjustment screw. See page 163
- Two insert pockets for faster cutting and better accuracy

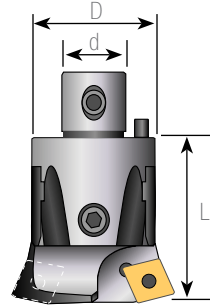

Cartridge type rough head

75° Integral Pocket Rough Heads

Part No.	Description	Range		D (mm)	d (mm)	L	Insert	Screw
		Min	Max					
6275100	D-22-75-400	.945"	1.181"	22	12	1.39"	CCMT 21.5_	6811250
6275105	D-27-75-409	1.142"	1.575"	27	15	1.65"	CCMT 32.5_	6811260
6275115	D-32-75-409	1.535"	1.969"	32	18	1.77"	CCMT 32.5_	6811260
6275120	D-42-75-300	1.929"	2.559"	42	24	2.20"	TCMT 1.81_	6811262
6275125	D-42-75-402	1.929"	2.559"	42	24	2.20"	CCMT 43_	6811266
6275130	D-42-75-402N	2.087"	2.559"	42	24	2.20"	CNMG 43_	6811270
6275135	D-54-75-300	2.48"	3.228"	54	28	2.60"	TCMT 1.81_	6811262
6275140	D-54-75-402	2.48"	3.228"	54	28	2.60"	CCMT 43_	6811 266
6275145	D-54-75-402N	2.48"	3.228"	54	28	2.60"	CNMG 43_	6811270

75° Cartridge Type Rough Heads

Part No.	Description	Range		Cartridge	D (mm)	d (mm)	L	Insert	Screw
		Min	Max						
6275150	D-68-75-2CT-300	3.15"	4.016"	2CT-75-300	68	36	3.39"	TCMT 1.81.5_	6811262
6275155	D-68-75-2CT-402	3.15"	4.016"	2CT-75-402	68	36	3.39"	CCMT 43_	6811266
6275160	D-68-75-2CT-402N	3.15"	4.016"	2CT-75-402N	68	36	3.39"	CNMG 43_	6811270
6275165	D-85-75-3CT-300	3.937"	4.921"	3CT-75-300	85	50	3.94"	TCMT 32.5_	6811262
6275170	D-85-75-3CT-402	3.937"	4.921"	3CT-75-402	85	50	3.94"	CCMT 43_	6811266
6275175	D-85-75-3CT-402N	3.937"	4.921"	3CT-75-402N	85	50	3.94"	CNMG 43_	6811270
6275180	D-100-75-3CT-300	4.921"	6.299"	3CT-75-300	110	60	3.94"	TCMT 32.5_	6811262
6275185	D-100-75-3CT-402	4.921"	6.299"	3CT-75-402	110	60	3.94"	CCMT 43_	6811266
6275190	D-100-75-3CT-402N	4.921"	6.299"	3CT-75-402N	110	60	3.94"	CNMG 43_	6811270
6275195	D-200-75-3CT-300	6.299"	8.661"	2CT-75-300	145	60	3.94"	TCMT 32.5_	6811262
6275200	D-200-75-3CT-402	6.299"	8.661"	3CT-75-402	145	60	3.94"	CCMT 43_	6811266
6275205	D-200-75-3CT-402N	6.299"	8.661"	3CT-75-402N	145	60	3.94"	CNMG 432_	6811270

AccuSET dial not available on small rough heads due to their design differences.

75° Lead Angle Rough Heads – Range: 8.661 to 19.685"



SafetySET feature not available on large boring heads due to their design differences.

Features

- Two AccuSET .0001" graduated dials allow setting both inserts simultaneously
- Top quality steel alloy hardened to 58-60 HRC
- Precision ground components for accuracy



Inserts & Cartridges
pg. 199



Toolholders
pg. 203



Extensions & Reducers
pg. 213



Retention Knobs
pg. 228

75° lead angle heads tend to self center in the pilot hole, stabilizing the cut and maximizing stock removal rates.



Use large boring heads with direct mount toolholders or ADT 100-50 adapter and a toolholder with a 100mm connection. See page 188.

Adjustment Is This Easy

AccuSET graduated adjustment dial



Adjustable in 0.0001" increments

Metric dials available

.0001" dial allows operators to quickly set the finish head to any diameter.

Procedure:

1. Loosen locking screw
2. Remove any backlash
3. Rotate scale to desired setting
4. Tighten locking screw

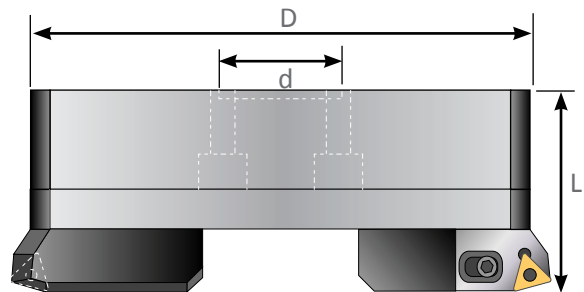

75° Large Rough Heads

Part No.	Description	Range		Cartridge	D (mm)	d (mm)	L	Insert	Screw
		Min	Max						
6275210	D-300-75-3CT-300	8.661"	12.598"	3CT-75-300	202	60	3.54"	TCMT 32.5_	6811262
6275215	D-300-75-3CT-402	8.661"	12.598"	3CT-75-402	202	60	3.54"	CCMT 43_	6811266
6275220	D-300-75-3CT-402N	8.661"	12.598"	3CT-75-402N	202	60	3.54"	CNMG 43_	6811270
6275225	D-400-75-3CT-300	11.417"	15.748"	3CT-75-300	272	60	3.54"	TCMT 32.5_	6811262
6275230	D-400-75-3CT-402	11.417"	15.748"	3CT-75-402	272	60	3.54"	CCMT 43_	6811266
6275235	D-400-75-3CT-402N	11.417"	15.748"	3CT-75-402N	272	60	3.54"	CNMG 43_	6811270
6275240	D-500-75-3CT-300	14.567"	19.685"	3CT-75-300	352	60	3.54"	TCMT 32.5_	6811262
6275245	D-500-75-3CT-402	14.567"	19.685"	3CT-75-402	352	60	3.54"	CCMT 43_	6811266
6275250	D-500-75-3CT-402N	14.567"	19.685"	3CT-75-402N	352	60	3.54"	CNMG 43_	6811270

SafetySET feature not available on large boring heads due to their design differences.



90° Lead Angle Rough Heads – Range: .945 to 8.661"



Integral pocket type

Features

- SpeedSET feature adjusts both slides at once and slides won't lose position during adjustment
- SafetySET feature prevents accidental damage to the adjustment screw. See page 163
- Two insert pockets for faster metal removal

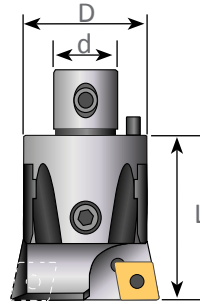

Cartridge type rough head

90° Integral Pocket Type Rough Heads

Part No.	Description	Range		D (mm)	d (mm)	L	Insert	Screw
		Min	Max					
6390100	D-22-90-400	.945"	1.181"	22	12	1.39"	CCMT 21.5_	6811250
6390105	D-27-90-409	1.142"	1.575"	27	15	1.65"	CCMT 32.5_	6811260
6390110	D-32-90-409	1.535"	1.969"	32	18	1.77"	CCMT 32.5_	6811260
6390115	D-42-90-300	1.929"	2.559"	42	24	2.20"	TCMT 32.5_	6811262
6390120	D-42-90-402	1.929"	2.559"	42	24	2.20"	CCMT 43_	6811266
6390125	D-42-90-402N	2.087"	2.559"	42	24	2.20"	CNMG 43_	6811270
6390130	D-54-90-300	2.48"	3.228"	54	28	2.60"	TCMT 32.5_	6811262
6390135	D-54-90-402	2.48"	3.228"	54	28	2.60"	CCMT 43_	6811266
6390140	D-54-90-402N	2.48"	3.228"	54	28	2.60"	CNMG 43_	6811270

90° Cartridge Type Rough Heads

Part No.	Description	Range		Cartridge	D (mm)	d (mm)	L	Insert	Screw
		Min	Max						
6390145	D-68-90-2CT-300	3.15"	4.016"	2CT-90-300	68	36	3.39"	TCMT 32.5_	6811262
6390150	D-68-90-2CT-402	3.15"	4.016"	2CT-90-402	68	36	3.39"	CCMT 43_	6811266
6390155	D-68-90-2CT-402N	3.15"	4.016"	2CT-90-402N	68	36	3.39"	CNMG 43_	6811270
6390160	D-85-90-3CT-300	3.937"	4.921"	3CT-90-300	85	50	3.94"	TCMT 32.5_	6811262
6390165	D-85-90-3CT-402	3.937"	4.921"	3CT-90-402	85	50	3.94"	CCMT 43_	6811266
6390170	D-85-90-3CT-402N	3.937"	4.921"	3CT-90-402N	85	50	3.94"	CNMG 43_	6811270
6390175	D-100-90-3CT-300	4.921"	6.299"	3CT-90-300	110	60	3.94"	TCMT 32.5_	6811262
6390180	D-100-90-3CT-402	4.921"	6.299"	3CT-90-402	110	60	3.94"	CCMT 43_	6811266
6390185	D-100-90-3CT-402N	4.921"	6.299"	3CT-90-402N	110	60	3.94"	CNMG 43_	6811270
6390190	D-200-90-3CT-300	6.299"	8.661"	2CT-90-300	145	60	3.94"	TCMT 32.5_	6811262
6390200	D-200-90-3CT-402	6.299"	8.661"	3CT-90-402	145	60	3.94"	CCMT 43_	6811266
6390205	D-200-90-3CT-402N	6.299"	8.661"	3CT-90-402N	145	60	3.94"	CNMG 43_	6811270

AccuSET, feature not available on small boring heads due to their design differences.

90° Lead Angle Rough Heads – Range: 8.661 to 19.685"



SafetySET feature not available on large boring heads due to their design differences.

Features

- Two AccuSET .0001" graduated dials allow setting both inserts simultaneously
- Top quality steel alloy hardened to 58-60 HRC
- Precision ground components for accuracy



Inserts & Cartridges
pg. 199



Toolholders
pg. 203



Extensions & Reducers
pg. 213



Retention Knobs
pg. 228

Use 90° lead angle heads when performing blind boring, or if the desired hole is not exactly on center with your pilot hole. The 90° lead will have less tendency to follow the pilot hole.

Adjustment Is This Easy

AccuSET graduated adjustment dial



Adjustable in 0.0001" increments

Metric dials available

.0001" dial allows operators to quickly set the finish head to any diameter.

Procedure:

1. Loosen locking screw
2. Remove any backlash
3. Rotate scale to desired setting
4. Tighten locking screw



Use large boring heads with direct mount toolholders or ADT 100-50 adapter and a toolholder with a 100mm connection. See "Toolholders for Large Boring Heads" on page 188.

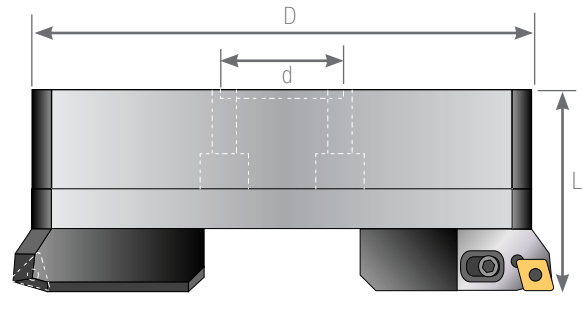

90° Large Rough Heads

Part No.	Description	Range		Cartridge	D (mm)	d (mm)	L	Insert	Screw
		Min	Max						
6390210	D-300-90-3CT-300	8.661"	12.598"	3CT-90-300	202	60	3.54"	TCMT 32.5_	6811262
6390215	D-300-90-3CT-402	8.661"	12.598"	3CT-90-402	202	60	3.54"	CCMT 43_	6811266
6390220	D-300-90-3CT-402N	8.661"	12.598"	3CT-90-402N	202	60	3.54"	CNMG 43_	6811270
6390225	D-400-90-3CT-300	11.417"	15.748"	3CT-90-300	272	60	3.54"	TCMT 32.5_	6811262
6390230	D-400-90-3CT-402	11.417"	15.748"	3CT-90-402	272	60	3.54"	CCMT 43_	6811266
6390235	D-400-90-3CT-402N	11.417"	15.748"	3CT-90-402N	272	60	3.54"	CNMG 43_	6811270
6390240	D-500-90-3CT-300	14.567"	19.685"	3CT-90-300	352	60	3.54"	TCMT 32.5_	6811262
6390245	D-500-90-3CT-402	14.567"	19.685"	3CT-90-402	352	60	3.54"	CCMT 43_	6811266
6390250	D-500-90-3CT-402N	14.567"	19.685"	3CT-90-402N	352	60	3.54"	CNMG 43_	6811270

SafetySET feature not available on large boring heads due to their design differences.



75° Lead Angle Finish Heads – Range: .945 to 8.661"

Features

- Spring-loaded slide won't lose position during adjustment
- AccuSET .0001" graduated dial allows fast and easy adjustments
- Designed for maximum rigidity and accuracy



Integral pocket type

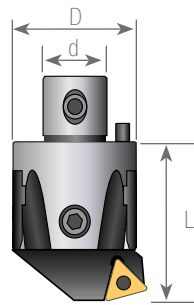

Cartridge type

75° Integral Pocket Type Finish Heads

Part No.	Description	Range		D (mm)	d (mm)	L	Insert	Screw
		Min	Max					
6275255	A-22-75-400	.945"	1.181"	22	12	1.39"	CCMT 21.5_	6811250
6275260	A-27-75-409	1.142"	1.575"	27	15	1.65"	CCMT 32.5_	6811260
6275265	A-32-75-409	1.535"	1.969"	32	18	1.77"	CCMT 32.5_	6811260
6275270	A-42-75-300	1.929"	2.559"	42	24	2.20"	TCMT 32.5_	6811262
6275275	A-54-75-300	2.48"	3.228"	54	28	2.60"	TCMT 32.5_	6811262

75° Cartridge Type Finish Heads

Part No.	Description	Range		Cartridge	D (mm)	d (mm)	L	Insert	Screw
		Min	Max						
6275280	A-68-75-2CT-300	3.15"	4.016"	2CT-75-300	68	36	3.39"	TCMT 32.5_	6811262
6275285	A-68-75-2CT-402	3.15"	4.016"	2CT-75-402	68	36	3.39"	CCMT 43_	6811266
6275290	A-68-75-2CT-402N	3.15"	4.016"	2CT-75-402N	68	36	3.39"	CNMG 43_	6811270
6275295	A-85-75-3CT-300	3.937"	4.921"	3CT-75-300	85	50	3.94"	TCMT 32.5_	6811262
6275300	A-85-75-3CT-402	3.937"	4.921"	3CT-75-402	85	50	3.94"	CCMT 43_	6811266
6275305	A-85-75-3CT-402N	3.937"	4.921"	3CT-75-402N	85	50	3.94"	CNMG 43_	6811270
6275310	A-100-75-3CT-300	4.921"	6.299"	3CT-75-300	110	60	3.94"	TCMT 32.5_	6811262
6275315	A-100-75-3CT-402	4.921"	6.299"	3CT-75-402	110	60	3.94"	CCMT 43_	6811266
6275320	A-100-75-3CT-402N	4.921"	6.299"	3CT-75-402N	110	60	3.94"	CNMG 43_	6811270
6275325	A-200-75-3CT-300	6.299"	8.661"	2CT-75-300	145	60	3.94"	TCMT 32.5_	6811262
6275330	A-200-75-3CT-402	6.299"	8.661"	3CT-75-402	145	60	3.94"	CCMT 43_	6811266
6275335	A-200-75-3CT-402N	6.299"	8.661"	3CT-75-402N	145	60	3.94"	CNMG 43_	6811270

75° UltraFINE Finish Heads – Range: up to 19.685"



Uses ISO standard inserts

Features

- Accu-Set slide includes graduated dial for fast adjustments in 0.0001" increments
- Manufactured from top quality steel alloy, hardened to 58-60 HRC to minimize wear
- Pin-and-taper coupling system insures absolute positioning and maximum rigidity

UltraFINE finish heads feature an 11° relief angle that provides an ultra-smooth finish, reducing the need for extra operations.

Scan the QR code or visit the link below for more information about UltraFINE heads.
<http://ow.ly/tKQyH>



Techniks PinzBOHR boring heads provide outstanding repeatability because of our extremely rigid design.

Our boring heads are made to such high standards that even the adjusting screws on our finish heads are finely ground for smooth, reliable, and precise adjustment.

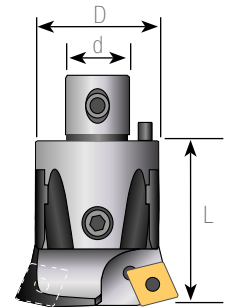

UltraFINE Integral Pocket Finish Heads – 75° Lead Angle

Part No.	Description	Min	Max	D	d	L	Insert	Screw
6275253	A-22-75-310 W	.945"	1.181"	22	12	1.39"	CCMT 0602_	6811250
6275258	A-27-75-310 W	1.142"	1.575"	27	15	1.65"	CCMT 09T3_	6811260
6275263	A-32-75-310 W	1.535"	1.969"	32	18	1.77"	CCMT 09T3_	6811260
6275271	A-42-75-311 W	1.929"	2.559"	42	24	2.20"	TCMT 16T3_	6811262
6275276	A-54-75-311 W	2.48"	3.228"	54	28	2.59"	CCMT 1204_	6811262

UltraFINE Cartridge Finish Heads – 75° Lead Angle

Part No.	Description	Min	Max	D	d	L	Cartridge	Screw
6275281	A-68-75-2CT-311 W	3.15"	4.016"	68	36	3.39"	2CT 75 311	6811262
6275296	A-85-75-3CT-311 W	3.94"	4.921"	85	50	3.94"	3CT 75 311	6811266
6275311	A-100-75-3CT-311 W	4.92"	6.299"	110	60	3.94"	3CT 75 311	6811270
6275326	A-200-75-3CT-311 W	6.29"	8.66"	145	60	3.94"	3CT 75 311	6811262

UltraFINE Large Finish Heads – 75° Lead Angle

Part No.	Description	Min	Max	D	d	L	Cartridge	Screw
6275341	A-300-75-3CT-311 W	8.661"	12.598"	202	60	3.54"	3CT 75 311	6811262
6275356	A-400-75-3CT-311 W	11.417"	15.748"	272	60	3.54"	3CT 75 311	6811266
6275371	A-500-75-3CT-311-W	14.566"	19.685"	2352	60	3.54"	3CT 75 311	6811270

Note: All wrenches are included with each boring head. No special tools are needed.

Metric heads are available on request.. UltraFINE indexable cartridges are on page 182.



75° Lead Angle Finish Heads – Range: 8.661 to 19.685"



Features

- AccuSET .0001" graduated dial for easy adjustments
- Designed for maximum rigidity and accuracy
- Top quality steel alloy hardened to 58-60 HRc



Inserts & Cartridges
pg. 199



Toolholders
pg. 203



Extensions & Reducers
pg. 213



Retention Knobs
pg. 228

75° lead angle head tends to self-center in the pilot hole, stabilizing the cut and maximizing stock removal rates.

Adjustment Is This Easy

AccuSET graduated adjustment dial



Adjustable in 0.0001" increments

Metric dials available

.0001" dial allows operators to quickly set the finish head to any diameter.

Procedure:

1. Loosen locking screw
2. Remove any backlash
3. Rotate scale to desired setting
4. Tighten locking screw



Use large boring heads with direct mount toolholders or ADT 100-50 adapter and a toolholder with a 100mm connection. See page 188.

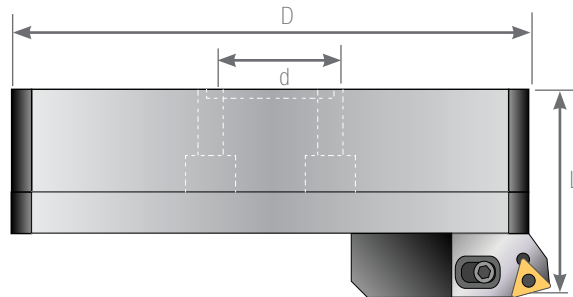

75° Large Finish Heads

Part No.	Description	Range		Cartridge	D (mm)	d (mm)	L	Insert	Screw
		Min	Max						
6275340	A-300-75-3CT-300	8.661"	12.598"	3CT.75.300	202	60	3.54"	TCMT 32.5_	6811262
6275345	A-300-75-3CT-402	8.661"	12.598"	3CT.75.402	202	60	3.54"	CCMT 43_	6811266
6275350	A-300-75-3CT-402N	8.661"	12.598"	3CT.75.402N	202	60	3.54"	CNMG 43_	6811270
6275355	A-400-75-3CT-300	11.417"	15.748"	3CT.75.300	272	60	3.54"	TCMT 32.5_	6811262
6275360	A-400-75-3CT-402	11.417"	15.748"	3CT.75.402	272	60	3.54"	CCMT 43_	6811266
6275365	A-400-75-3CT-402N	11.417"	15.748"	3CT.75.402N	272	60	3.54"	CNMG 43_	6811270
6275370	A-500-75-3CT-300	14.567"	19.685"	3CT.75.300	352	60	3.54"	TCMT 32.5_	6811262
6275375	A-500-75-3CT-402	14.567"	19.685"	3CT.75.402	352	60	3.54"	CCMT 43_	6811266
6275380	A-500-75-3CT-402N	14.567"	19.685"	3CT.75.402N	352	60	3.54"	CNMG 43_	6811270

90° Lead Angle Finish Heads – Range: .945 to 8.661"



Integral pocket type

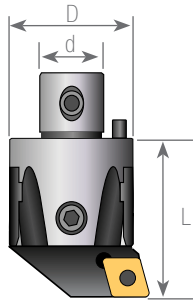

Features

- Spring-loaded slide won't lose position during adjustment
- AccuSET .0001" graduated dial for fast & easy adjustments
- Designed for maximum rigidity and accuracy



Cartridge type

90° Integral Pocket Type Finish Heads

Part No.	Description	Range		D (mm)	d (mm)	L	Insert	Screw
		Min	Max					
6390255	A-22-90-400	.945"	1.181"	22	12	1.39"	CCMT 21.5_	6811250
6390260	A-27-90-409	1.142"	1.575"	27	15	1.65"	CCMT 32.5_	6811260
6390265	A-32-90-300	1.535"	1.969"	32	18	1.77"	TCMT 32.5_	6811262
6390270	A-32-90-409	1.535"	1.969"	32	18	1.77"	CCMT 32.5_	6811260
6390275	A-42-90-300	1.929"	2.559"	42	24	2.20"	TCMT 32.5_	6811262
6390280	A-42-90-402	1.929"	2.559"	42	24	2.20"	CCMT 43_	6811266
6390285	A-42-90-402N	2.087"	2.559"	42	24	2.20"	CNMG 43_	6811270
6390290	A-54-90-300	2.48"	3.228"	54	28	2.60"	TCMT 32.5_	6811262
6390295	A-54-90-402	2.48"	3.228"	54	28	2.60"	CCMT 43_	6811266
6390300	A-54-90-402N	2.48"	3.228"	54	28	2.60"	CNMG 43_	6811270

90° Cartridge Type Finish Heads

Part No.	Description	Range		Cartridge	D (mm)	d (mm)	L	Insert	Screw
		Min	Max						
6390305	A-68-90-2CT-300	3.15"	4.016"	2CT-90-300	68	36	3.39"	TCMT 32.5_	6811262
6390310	A-68-90-2CT-402	3.15"	4.016"	2CT-90-402	68	36	3.39"	CCMT 43_	6811266
6390315	A-68-90-2CT-402N	3.15"	4.016"	2CT-90-402N	68	36	3.39"	CNMG 43_	6811270
6390320	A-85-90-3CT-300	3.937"	4.921"	3CT-90-300	85	50	3.94"	TCMT 32.5_	6811262
6390325	A-85-90-3CT-402	3.937"	4.921"	3CT-90-402	85	50	3.94"	CCMT 43_	6811266
6390330	A-85-90-3CT-402N	3.937"	4.921"	3CT-90-402N	85	50	3.94"	CNMG 43_	6811270
6390335	A-100-90-3CT-300	4.921"	6.299"	3CT-90-300	110	60	3.94"	TCMT 32.5_	6811262
6390340	A-100-90-3CT-402	4.921"	6.299"	3CT-90-402	110	60	3.94"	CCMT 43_	6811266
6390345	A-100-90-3CT-402N	4.921"	6.299"	3CT-90-402N	110	60	3.94"	CNMG 43_	6811270
6390350	A-200-90-3CT-300	6.299"	8.661"	2CT-90-300	145	60	3.94"	TCMT 32.5_	6811262
6390355	A-200-90-3CT-402	6.299"	8.661"	3CT-90-402	145	60	3.94"	CCMT 43_	6811266
6390360	A-200-90-3CT-402N	6.299"	8.661"	3CT-90-402N	145	60	3.94"	CNMG 43_	6811270



90° UltraFINE Finish Heads – Range: up to 19.685"



Uses ISO standard inserts

Features

- Accu-Set slide includes graduated dial for fast adjustments in 0.0001" increments
- Manufactured from top quality steel alloy, hardened to 58-60 HRc to minimize wear
- Pin-and-taper coupling system insures absolute positioning and maximum rigidity

UltraFINE finish heads feature an 11° relief angle that provides an ultra-smooth finish, reducing the need for extra operations.

Scan the QR code or visit the link below for more information about UltraFINE heads.
<http://ow.ly/tKQyH>



Techniks PinzBOHR boring heads provide outstanding repeatability because of our extremely rigid design.

Our boring heads are made to such high standards that even the adjusting screws on our finish heads are finely ground for smooth, reliable, and precise adjustment.

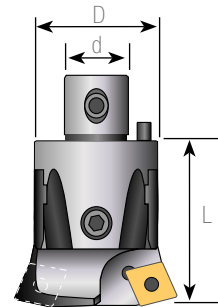

UltraFINE Integral Pocket Finish Heads – 90° Lead Angle

Part No.	Description	Min	Max	D	d	L	Insert	Screw
6390253	A-22-90-310 W	.945"	1.181"	22	12	1.39"	CCMT 0602_	6811250
6390258	A-27-90-310 W	1.142"	1.575"	27	15	1.65"	CCMT 09T3_	6811260
6390266	A-32-90-310 W	1.535"	1.969"	32	18	1.77"	CCMT 09T3_	6811260
6390276	A-42-90-311 W	1.929"	2.559"	42	24	2.20"	TCMT 16T3_	6811262
6390291	A-54-90-311 W	2.48"	3.228"	54	28	2.59"	CCMT 1204_	6811262

UltraFINE Cartridge Finish Heads – 90° Lead Angle

Part No.	Description	Min	Max	D	d	L	Cartridge	Screw
6390306	A-68-90-2CT-311 W	3.15"	4.016"	68	36	3.39"	2CT 90 311	6811262
6390321	A-85-90-3CT-311 W	3.94"	4.921"	85	50	3.94"	3CT 90 311	6811266
6390336	A-100-90-3CT-311 W	4.92"	6.299"	110	60	3.94"	3CT 90 311	6811270
6390351	A-200-90-3CT-311 W	6.29"	8.66"	145	60	3.94"	3CT 90 311	6811262

UltraFINE Large Finish Heads – 90° Lead Angle

Part No.	Description	Min	Max	D	d	L	Cartridge	Screw
6390366	A-300-90-3CT-311 W	8.661"	12.598"	202	60	3.54"	3CT 90 311	6811262
6390381	A-400-90-3CT-311 W	11.417"	15.748"	272	60	3.54"	3CT 90 311	6811266
6390396	A-500-90-3CT-311 W	14.566"	19.685"	2352	60	3.54"	3CT 90 311	6811270

Note: All wrenches are included with each boring head. No special tools are needed.

Metric heads are available on request. UltraFINE indexable cartridges are on page 183.

90° Lead Angle Finish Heads – Range: 8.661 to 19.685"



Features

- AccuSET .0001" graduated dial for easy adjustments
- Designed for maximum rigidity and accuracy
- Top quality steel alloy hardened to 58-60 HRC



Inserts & Cartridges
pg. 199



Toolholders
pg. 203



Extensions & Reducers
pg. 213



Retention Knobs
pg. 228

Use 90° lead angle heads when performing blind boring, or if the desired hole is not exactly on center with your pilot hole. The 90° lead will have less tendency to follow the pilot hole.

Adjustment Is This Easy

AccuSET graduated adjustment dial



Adjustable in 0.0001" increments

Metric dials available

.0001" dial allows operators to quickly set the finish head to any diameter.

Procedure:

1. Loosen locking screw
2. Remove any backlash
3. Rotate scale to desired setting
4. Tighten locking screw



Use large boring heads with direct mount toolholders or ADT 100-50 adapter and a toolholder with a 100mm connection. See page 188.

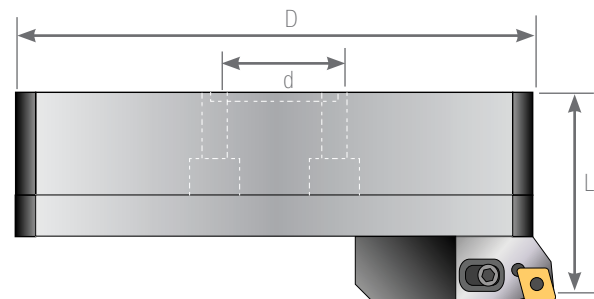

90° Large Finish Heads

Part No.	Description	Range		Cartridge	D (mm)	d (mm)	L	Insert	Screw
		Min	Max						
6390365	A-300-90-3CT-300	8.661"	12.598"	3CT-90-300	202	60	3.54"	TCMT 32.5_	6811262
6390370	A-300-90-3CT-402	8.661"	12.598"	3CT-90-402	202	60	3.54"	CCMT 43_	6811266
6390375	A-300-90-3CT-402N	8.661"	12.598"	3CT-90-402N	202	60	3.54"	CNMG 43_	6811270
6390380	A-400-90-3CT-300	11.417"	15.748"	3CT-90-300	272	60	3.54"	TCMT 32.5_	6811262
6390385	A-400-90-3CT-402	11.417"	15.748"	3CT-90-402	272	60	3.54"	CCMT 43_	6811266
6390390	A-400-90-3CT-402N	11.417"	15.748"	3CT-90-402N	272	60	3.54"	CNMG 43_	6811270
6390395	A-500-90-3CT-300	14.567"	19.685"	3CT-90-300	352	60	3.54"	TCMT 32.5_	6811262
6390400	A-500-90-3CT-402	14.567"	19.685"	3CT-90-402	352	60	3.54"	CCMT 43_	6811266
6390405	A-500-90-3CT-402N	14.567"	19.685"	3CT-90-402N	352	60	3.54"	CNMG 43_	6811270



Indexable Cartridges 75° Lead Angle



75° type 300



75° type 402

Features

- Change lead angle or insert style by simply changing cartridges
- Precision ground accuracy
- Symmetrical or staggered boring

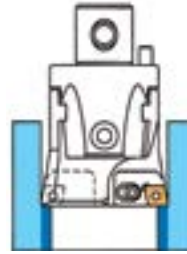
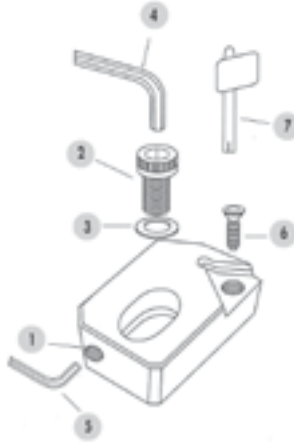

symmetrical boring

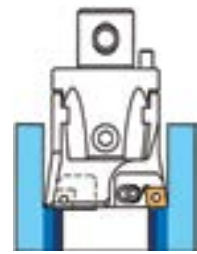

staggered boring

Staggered boring is possible by substituting a staggered cartridge in place of the regular cartridge.

This .020" of axial stagger will accommodate most staggered, or "stepped" boring processes. Order staggered cartridges from the table at bottom of page.

75° Lead Angle Cartridges for Symmetrical Boring

Part No.	Description	Insert	1	2	3	4	5	6	7
6675125	2CT-75-300	TCMT 32.5_	D-68-29	A-68-26	D-68-28	H5	H2	6811260	9355555
6675130	2CT-75-402	CCMT 43_	D-68-29	A-68-26	D-68-28	H5	H2	6811266	9355666
6675135	2CT-75-402N	CNMG 43_	D-68-29	A-68-26	D-68-28	H5	H2	6811270	9322116
6675140	3CT-75-300	TCMT 32.5_	D-85-29	D-85-27	D-68-28	H5	H3	6811262	9355555
6675145	3CT-75-402	CCMT 43_	D-85-29	D-85-27	D-68-28	H5	H3	6811266	9355666
6675150	3CT-75-402N	CNMG 43_	D-85-29	D-85-27	D-68-28	H5	H3	6811270	9322116

75° UltraFINE Lead Angle Cartridges for Symmetrical Boring

Part No.	Description	Insert	1	2	3	4	5	6	7
6675126	2CT-75-311	TCMT 09T3_	D-68-29	A-68-26	D-68-28	H5	H2	6811260	T10
6675141	3CT-75-311	CCMT 1204_	D-85-29	A-68-27	D-68-28	H5	H3	6811266	T10

Indexable Cartridges 90° Lead Angle



Features

- Change lead angle or insert style by simply changing cartridges
- Precision ground accuracy
- Symmetrical or staggered boring

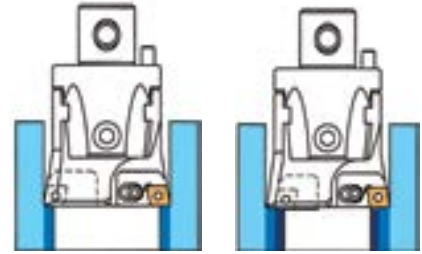

symmetrical boring

staggered boring

Staggered boring is possible by substituting a staggered cartridge in place of the regular cartridge.

This .020" of axial stagger will accommodate most staggered, or "stepped" boring processes. Order staggered cartridges from the table at bottom of page.



90° type 300



90° type 402

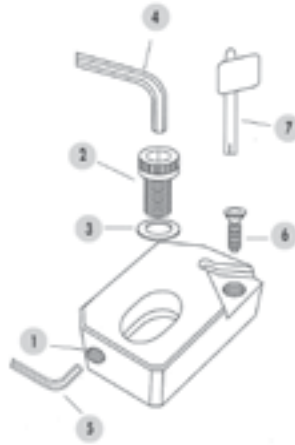

90° Lead Angle Cartridges for Symmetrical Boring

Part No.	Description	Insert	1	2	3	4	5	6	7
6690125	2CT-90-300	TCMT 32.5_	D-68-29	A-68-26	D-68-28	H5	H2	6811260	9355555
6690130	2CT-90-402	CCMT 43_	D-68-29	A-68-26	D-68-28	H5	H2	6811266	9355666
6690135	2CT-90-402N	CNMG 43_	D-68-29	A-68-26	D-68-28	H5	H2	6811270	9322116
6690140	3CT-90-300	TCMT 32.5_	D-85-29	D-85-27	D-68-28	H5	H3	6811262	9355555
6690145	3CT-90-402	CCMT 43_	D-85-29	D-85-27	D-68-28	H5	H3	6811266	9355666
6690150	3CT-90-402N	CNMG 43_	D-85-29	D-85-27	D-68-28	H5	H3	6811270	9322116

90° UltraFINE Lead Angle Cartridges for Symmetrical Boring

Part No.	Description	Insert	1	2	3	4	5	6	7
6690126	2CT-90-311	TCMT 09T3_	D-68-29	A-68-26	D-68-28	H5	H2	6811260	T10
6690141	3CT-90-311	CCMT 1204_	D-85-29	A-68-27	D-68-28	H5	H3	6811266	T10

90° Lead Angle Cartridges for Staggered Boring

Part No.	Description	Insert	1	2	3	4	5	6	7
6690155	2CT-90-300S	TCMT 32.5_	D-68-29	A-68-26	D-68-28	H5	H2	6811260	9355555
6690160	2CT-90-402S	CCMT 43_	D-68-29	A-68-26	D-68-28	H5	H2	6811266	9355666
6690165	2CT-90-402NS	CNMG 43_	D-68-29	A-68-26	D-68-28	H5	H2	6811270	9322116
6690170	3CT-90-300S	TCMT 32.5_	D-85-29	D-85-27	D-68-28	H5	H3	6811262	9355555
6690175	3CT-90-402S	CCMT 43_	D-85-29	D-85-27	D-68-28	H5	H3	6811266	9355666
6690180	3CT-90-402NS	CNMG 43_	D-85-29	D-85-27	D-68-28	H5	H3	6811270	9322116

High-Performance Boring Inserts



Features

- ISO standard inserts
- TCMT, CCMT, CNMG, EPMT, and DCMT
- Use Magia LT-1000 grade inserts for extended insert life in all types of materials

Tech Tips

Roughing:

Use the largest available corner radius unless otherwise specified.

Finish boring:

Use the smallest available corner radius to minimize tool deflection.

Best finish:

Generally start with your feed at 25% of insert nose radius. Optimal speeds and feeds depend upon material, tool overhang, and setup conditions.

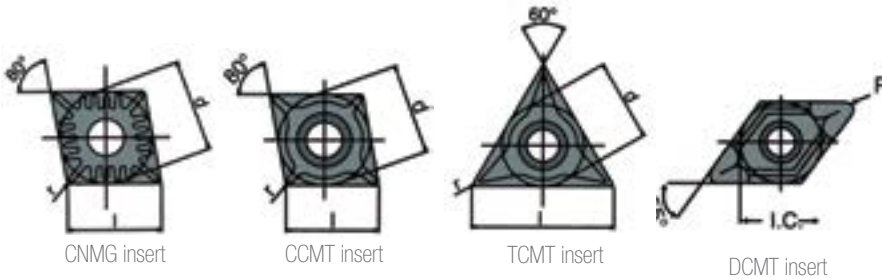

CNMG insert

CCMT insert

TCMT insert

DCMT insert

Inserts marked in green are for **aluminum & alloys**.

For extended insert life we recommend LT 1000 grade.

We recommend LT1000 grade inserts for maximum insert performance. LT1000 grade features an advanced PVD coating that is 14 microns thick and lasts 250% longer than other inserts.

Part No.	Description (ANSI)	Description (ISO)	Grade	l	s	r	Operation
3663336	CCGX 2(1.5)1 LH HP	CCGX 060204 LH	101	0.252	0.094	0.016	General
3663337	CCGX 3(2.5)1 LH HP	CCGX 09T304 LH	101	0.382	0.156	0.016	General
3663338	CCGX 3(2.5)2 LH HP	CCGX 09T308 LH	101	0.382	0.156	0.031	General
3663339	CCGX 432 LH HP	CCGX 120408 LH	101	0.508	0.187	0.031	General
3663311	CCMT 2(1.5)0 HF	CCMT 060202 HF	251	0.252	0.094	0.008	General
3664411	CCMT 2(1.5)1 NN	CCMT 060204 NN	LT 10	0.254	0.094	0.016	General
3668011	CCMT 2(1.5)1 NN	CCMT 060204 NN	LT 1000	0.254	0.094	0.016	General
3663399	CCMT 2(1.5)2 HM	CCMT 060208 HM	251	0.252	0.094	0.031	General
3663344	CCMT 3(2.5)0 HF	CCMT 09T302 HF	251	0.382	0.156	0.008	Finishing
3664413	CCMT 3(2.5)1 NN	CCMT 09T304 NN	LT 10	0.381	0.156	0.016	General
3668021	CCMT 3(2.5)1 NN	CCMT 09T304 NN	LT 1000	0.381	0.156	0.016	General
3664416	CCMT 3(2.5)2 NN	CCMT 09T308 NN	LT 10	0.381	0.156	0.036	General
3668026	CCMT 3(2.5)2 NN	CCMT 09T308 NN	LT 1000	0.381	0.156	0.036	General
3664422	CCMT 431 NN	CCMT 120404 NN	LT 1000	0.508	0.187	0.016	General
3664421	CCMT 431 NN	CCMT 120404 NN	LT 10	0.508	0.187	0.016	General
3664427	CCMT 432 NN	CCMT 120408 NN	LT 1000	0.508	0.187	0.036	General
3664425	CCMT 432 NN	CCMT 120408 NN	LT 10	0.508	0.187	0.036	General
3664429	CCMT 433 NN	CCMT 120412 NN	LT 1000	0.508	0.187	0.047	General
3631083	CCMT 433 NN	CCMT 120412 NN	LT 10	0.508	0.187	0.047	General
6607901	CNGG 431 ALU	CNGG 120404 ALU	LT 05	0.508	0.187	0.016	General
6607905	CNGG 432 ALU	CNGG 120408 ALU	LT 05	0.508	0.187	0.031	General



CC__



CCMT



CN__

Inserts continued on the next page.

High-Performance Boring Inserts

Inserts marked in green are for **aluminum & alloys**.

For extended insert life we recommend LT 1000 grade.

Part No.	Description (ANSI)	Description (ISO)	Grade	l	s	r	Operation
6607029	CNMG 431 NN	CNMG 120404 NN	LT 10	0.508	0.187	0.016	General
6608011	CNMG 431 NN	CNMG 120404 NN	LT 1000	0.508	0.187	0.016	General
6601436	CNMG 432 NM	CNMG 120408 NM	LT 10	0.508	0.187	0.031	Roughing
6601437	CNMG 432 NM	CNMG 120408 NM	LT 1000	0.508	0.187	0.031	Roughing
6607033	CNMG 432 NN	CNM G120408 NN	LT 10	0.508	0.187	0.031	General
6608016	CNMG 432 NN	CNMG 120408 NN	LT 1000	0.508	0.187	0.031	General
6601446	CNMG 432 NR	CNMG 120408 NR	LT 10	0.508	0.187	0.031	Roughing
6608026	CNMG 432 NX	CNMG 120408 NX	LT 1000	0.508	0.187	0.031	General
6607037	CNMG 433 NN	CNMG 120412 NN	LT 10	0.508	0.187	0.047	Roughing
6608021	CNMG 433 NN	CNMG 120412 NN	LT 1000	0.508	0.187	0.047	Roughing
3764421	DCMT 2(1.5)1 NN	DCMT 070304 NN	LT 10	0.305	0.094	0.016	Finishing
3768811	DCMT 2(1.5)1 NN	DCMT 070304 NN	LT 1000	0.305	0.094	0.016	Finishing
3764424	DCMT 3(2.5)1 NN	DCMT 11T304 NN	LT 10	0.458	0.156	0.016	General
3768821	DCMT 3(2.5)1 NN	DCMT 11T304 NN	LT 1000	0.458	0.156	0.016	General
3764427	DCMT 3(2.5)2 NN	DCMT 11T308 NN	LT 10	0.458	0.156	0.031	General
3768826	DCMT 3(2.5)2 NN	DCMT 11T308 NN	LT 1000	0.458	0.156	0.031	General
3732040	DCMT 432 PM4	DCMT 150408 PM4	5615	0.591	0.187	0.031	General
3563336	TCGX21.51 LH HP	TCGX110204 LH HP	101	0.433	0.94	0.016	Finishing
3563337	TCGX32.52 LH HP	TCGX16T308 LH HP	101	0.65	0.156	0.031	General
3533010	TCMT 1.2(1).50 PF4	TCMT 06T102 PF4	5615	0.378	0.094	0.004	Finishing
3533020	TCMT 1.2(1)1 PF4	TCMT 06T104 PF4	5625	0.378	0.094	0.008	Finishing
3563311	TCMT 1.8(1.5)0 HF	TCMT 090202 HF	251	0.378	0.094	0.008	Finishing
3563399	TCMT 1.8(1.5)2 HF	TCMT 090208 HF	251	0.378	0.094	0.016	General
3533033	TCMT 1.8(1.5)1 HM	TCMT 090204 HM	251	0.378	0.094	0.016	General
3533030	TCMT 1.8(1.5)1 PF4	TCMT 090204 PF4	5625	0.378	0.094	0.016	Finishing
3563388	TCMT 1.8(1.5)2 HM	TCMT090208 HM	251	0.378	0.094	0.031	General
3564431	TCMT 2(1.5)1 NN	TCMT 110204 NN	LT 10	0.433	0.094	0.016	Finishing
3568831	TCMT 2(1.5)1 NN	TCMT 110204 NN	LT 1000	0.433	0.094	0.016	Finishing
3564435	TCMT 2(1.5)2 NN	TCMT 110208 NN	LT 10	0.433	0.094	0.031	General
3568841	TCMT 2(1.5)2 NN	TCMT 110208 NN	LT 1000	0.433	0.094	0.031	General
3564438	TCMT 3(2.5)1 NN	TCMT 16T304 NN	LT 10	0.65	0.156	0.016	General
3568851	TCMT 3(2.5)1 NN	TCMT 16T304 NN	LT 1000	0.65	0.156	0.016	General
3564441	TCMT 3(2.5)2 NN	TCMT 16T308 NN	LT 10	0.65	0.156	0.031	General
3568861	TCMT 3(2.5)2 NN	TCMT 16T308 NN	LT 1000	0.65	0.156	0.031	General



CNMG



DCMT



TC_ _

Choosing & Using PinzBOHR Boring Heads

Using 75° Boring Heads

Use a 75-degree head for thru holes when the hole position is accurate. A 75-degree head will tend to follow a pre-existing hole. A 75-degree head can also be used when there is a lot of stock to be removed. The lead angle will allow higher feed rates.

Using 90° Boring Heads

Use a 90-degree boring head when a hole is off-center, shifted, or off-angle. The 90-degree lead angle will have fewer tendencies to follow the existing hole. It is also used for blind or stepped holes and is the most versatile of our heads.

Using Boring Bars

The diameter of the boring bar should always be less than the diameter of the pre-existing hole to allow proper chip evacuation.

5:1 length-to-diameter ratios can be achieved when roughing with steel bars.

3:1 length-to-diameter ratios can be achieved when finishing with steel bars.

7:1 length-to-diameter ratios can be achieved with carbide bars.

Three Major Influences on Boring

1. Depth of Cut (D.O.C.)

To determine the depth of a cut, take the finish diameter, minus the starting diameter and divide by two (2). The D.O.C. should always be greater than or equal to the nose radius of the insert. This will produce a stable cut with axial cutting forces. When D.O.C. is less than the radius, the forces are radial, and can cause chatter and deflection.

2. Feed Rate (IPR)

Feeds and speeds are always dependent upon material, machine, setup conditions (fixturing) and tool over-hang. The feed rate (IPR) should always be larger than the hone of the insert and at least 25% of the nose radius. This creates full use of the chip breaker. An IPR less than the hone will produce vibration, which will affect the tool life and finish.

3. Speed (SFPM)

Speed is the function of coating, nose radius, and over-hang. Higher speeds typically produce a better finish, shorter cycling times and better chip evacuation. Lower speed reduces the possibility of chatter, but also has higher cycle times and poorer quality finishes. This can also cause a built-up edge and reduce insert life. Sometimes coatings can be used to run higher surface footage, create better finish, and limit built-up edges.



75° Lead Angle Rough Head



90° Lead Angle Rough Head



Carbide or HSS Boring Bars



Use Micro Heads with Boring Bars

PinzBOHR High Precision CAT40 Toolholders



Features

- Exceed industry standards for taper accuracy and concentricity
- Two offset axial tapered locking screws maximize rigidity and allow fast tool changes
- Reducers allow different size boring heads to be used with the same toolholder
- Use extensions to increase boring depth

Match the "d" dimension on toolholder and boring head for proper selection.



Boring Heads
pg. 188



Inserts and Cartridges
pg. 199



Extensions & Reducers
pg. 213



Retention Knobs
pg. 228

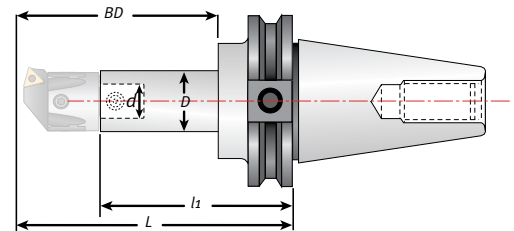

Boring depth (BD) is tool length plus boring head.

CAT40 Boring Toolholders

Part No.	Description	D (mm)	d (mm)	BD	L	l1	Coupling Screw
6133250	CT-340-22-80	22	12	3.150"	4.65"	3.31"	6811510
6133255	CT-340-22-100	22	12	3.937"	5.43"	4.09"	6811510
6133260	CT-340-27-55	27	15	2.165"	3.54"	1.89"	6811520
6133265	CT-340-27-100	27	15	3.937"	5.43"	3.78"	6811520
6133270	CT-340-27-130	27	15	5.118"	6.61"	4.96"	6811520
6133275	CT-340-32-60	32	18	2.362"	3.78"	2.01"	6811530
6133280	CT-340-32-100	32	18	3.937"	5.43"	3.66"	6811530
6133285	CT-340-32-130	32	18	5.118"	6.61"	4.84"	6811530
6133290	CT-340-42-75	42	24	2.953"	4.41"	2.20"	6811540
6133295	CT-340-42-120	42	24	4.724"	5.59"	3.86"	6811540
6134300	CT-340-42-160	42	24	6.300"	7.17"	4.96"	6811540
6134305	CT-340-42-200	42	24	7.874"	8.74"	6.54"	6811540
6134310	CT-340-54-120	54	28	4.724"	5.59"	2.99"	6811550
6134315	CT-340-54-160	54	28	6.300"	7.17"	4.57"	6811550
6134320	CT-340-54-200	54	28	7.874"	8.74"	6.14"	6811550
6134325	CT-340-68-160	68	36	6.300"	7.20"	3.82"	6811560
6134330	CT-340-68-200	68	36	7.874"	8.78"	5.39"	6811560
6134335	CT-340-85-200	85	50	7.874"	8.819"	4.88"	6811570
6134338	CT-340-100-200	100	60	7.874"	8.819"	4.88"	6811580

For large head toolholders, see page 188.

PinzBOHR High Precision CAT40 Coolant-Thru Toolholders



Features

- Exceed industry standards for taper accuracy and concentricity
- Two offset axial tapered locking screws maximize rigidity and allow fast tool changes
- Reducers allow different size boring heads to be used with the same toolholder
- Use extensions to increase boring depth

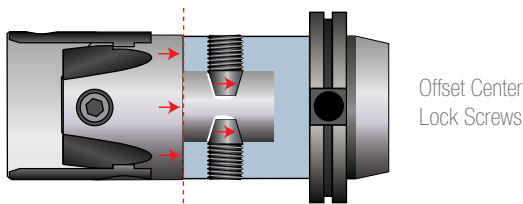

Our **modular coupling system** allows heads to be changed without removing tools from the spindle. Two offset center lock screws apply maximum tightening force between the boring head and the toolholder. This increases rigidity and enhances vibration dampening characteristics.

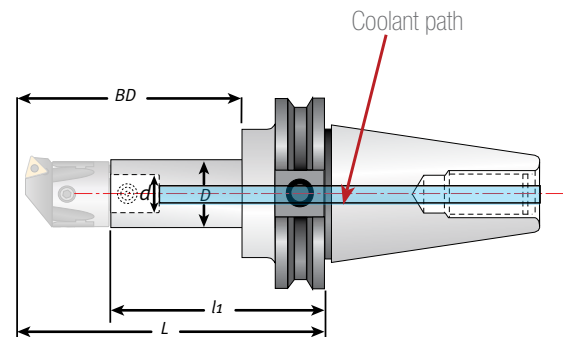

Match the "d" dimension on toolholder and boring head for proper selection. Boring depth (BD) is tool length plus boring head.

CAT40 Coolant-thru

Part No.	Description	D (mm)	d (mm)	BD	L	l1	Coupling Screw
6133257	CT-340-22-100-R	22	12	3.937"	5.43"	4.09"	6811510
6133252	CT-340-22-80-R	22	12	3.150"	4.65"	3.31"	6811510
6133267	CT-340-27-100-R	27	15	3.937"	5.43"	3.78"	6811520
6133272	CT-340-27-130-R	27	15	5.118"	6.61"	4.96"	6811520
6133262	CT-340-27-55-R	27	15	2.165"	3.54"	1.89"	6811520
6133282	CT-340-32-100-R	32	18	3.937"	5.34"	3.66"	6811530
6133287	CT-340-32-130-R	32	18	5.118"	6.61"	4.84"	6811520
6133277	CT-340-32-60-R	32	18	2.362"	3.78"	2.01"	6811530
6133297	CT-340-42-120-R	42	24	4.724"	5.59"	3.39"	6811540
6134302	CT-340-42-160-R	42	24	6.300"	7.17"	4.96"	6811540
6134307	CT-340-42-200-R	42	24	7.874"	8.74"	6.54"	6811540
6133292	CT-340-42-75-R	42	24	2.953"	4.41"	2.20"	6811540
6134312	CT-340-54-120-R	54	28	4.724"	5.59"	2.99"	6811550
6134317	CT-340-54-160-R	54	28	6.300"	7.17"	4.57"	6811550
6134322	CT-340-54-200-R	54	28	7.874"	8.74"	6.14"	6811550
6134327	CT-340-68-160-R	68	36	6.300"	7.20"	3.82"	6811560
6134332	CT-340-68-200-R	68	36	7.874"	8.78"	5.39"	6811560
6134337	CT-340-85-200-R	85	50	7.874"	8.819"	4.88"	6811570
6134340	CT-340-100-200-R	100	60	7.874"	8.819"	4.88"	6811580

Blue indicates coolant. Blue For large head toolholders, see page 188.

PinzBOHR High Precision CAT50 Toolholders



Match the "d" dimension on toolholder and boring head for proper selection.

Features

- Exceed industry standards for taper accuracy and concentricity
- Two offset axial tapered locking screws maximize rigidity and allow fast tool changes
- Reducers allow different size boring heads to be used with the same toolholder
- Use extensions to increase boring depth

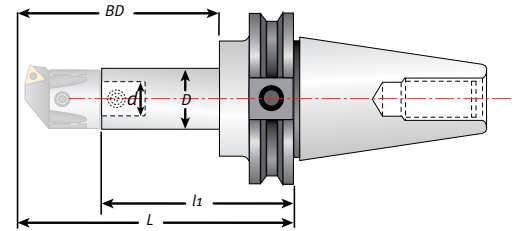

Boring depth (BD) is tool length plus boring head.

CAT50 Boring Toolholders

Part No.	Description	D (mm)	d (mm)	BD	L	l1	Coupling Screw
6141250	CT-350-22-80	22	12	3.150"	4.65"	3.31"	6811510
6141255	CT-350-22-100	22	12	3.937"	5.43"	4.09"	6811510
6141260	CT-350-27-55	27	15	2.165"	3.54"	1.89"	6811520
6141265	CT-350-27-100	27	15	3.937"	5.43"	3.78"	6811520
6141270	CT-350-27-130	27	15	5.118"	6.61"	4.96"	6811520
6141275	CT-350-32-60	32	18	2.362"	3.78"	2.01"	6811530
6141280	CT-350-32-130	32	18	5.118"	6.61"	4.84"	6811530
6141285	CT-350-32-160	32	18	6.299"	7.80"	6.02"	6811530
6141290	CT-350-42-75	42	24	2.953"	4.41"	2.20"	6811540
6141295	CT-350-42-160	42	24	6.299"	7.80"	5.59"	6811540
6141300	CT-350-42-200	42	24	7.874"	9.37"	7.17"	6811540
6141305	CT-350-54-90	54	28	3.543"	5.04"	2.44"	6811550
6141310	CT-350-54-160	54	28	6.299"	7.80"	5.20"	6811550
6141315	CT-350-54-200	54	28	7.874"	9.37"	6.77"	6811550
6141320	CT-350-68-115	68	36	4.528"	5.94"	2.56"	6811560
6141325	CT-350-68-200	68	36	7.874"	8.78"	5.39"	6811560
6141330	CT-350-68-260	68	36	10.236"	11.14"	7.76"	6811560
6141335	CT-350-85-200	85	50	7.874"	8.82"	4.88"	6811570
6141340	CT-350-85-260	85	50	10.236"	11.18"	7.24"	6811570
6141345	CT-350-85-320	85	50	12.598"	13.54"	9.61"	6811570
6141350	CT-350-100-190	100	60	7.480"	8.43"	4.49"	6811580
6141355	CT-350-100-260	100	60	10.236"	11.18"	7.24"	6811580
6141360	CT-350-100-320	100	60	12.598"	13.54"	9.61"	6811580
6166124	CT-550-160*	100	60	4.921"	6.30"	2.76"	6811590

For large head toolholders, see page 188.



PinzBOHR High Precision CAT50 Coolant-Thru Toolholders



Match the "d" dimension on toolholder and boring head for proper selection.



Boring Heads
pg. 188



Inserts and Cartridges
pg. 199



Extensions & Reducers
pg. 213



Retention Knobs
pg. 228

Features

- Exceed industry standards for taper accuracy and concentricity
- Two offset axial tapered locking screws maximize rigidity and allow fast tool changes
- Reducers allow different size boring heads to be used with the same toolholder
- Use extensions to increase boring depth

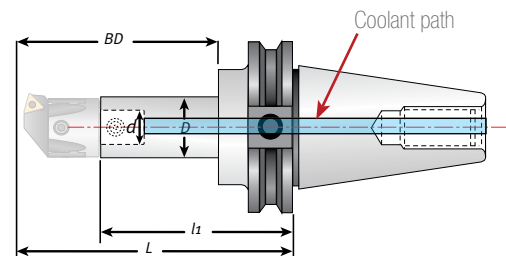

Boring depth (BD) is tool length plus boring head.

CAT50 Coolant-thru

Part No.	Description	D (mm)	d (mm)	BD	L	I1	Coupling Screw
6141252	CT-350-22-80-R	22	12	3.150"	4.65"	3.31"	6811510
6141257	CT-350-22-100-R	22	12	3.937"	5.43"	4.09"	6811510
6141262	CT-350-27-55-R	27	15	2.165"	3.54"	1.89"	6811520
6141267	CT-350-27-100-R	27	15	3.937"	5.43"	3.78"	6811520
6141272	CT-350-27-130-R	27	15	5.118"	6.61"	4.96"	6811520
6141277	CT-350-32-60-R	32	18	2.362"	3.78"	2.01"	6811530
6141282	CT-350-32-130-R	32	18	5.118"	6.61"	4.84"	6811530
6141287	CT-350-32-160-R	32	18	6.299"	7.80"	6.02"	6811530
6141292	CT-350-42-75-R	42	24	2.953"	4.41"	2.20"	6811540
6141297	CT-350-42-160-R	42	24	6.299"	7.80"	5.59"	6811540
6141302	CT-350-42-200-R	42	24	7.874"	9.37"	7.17"	6811540
6141307	CT-350-54-90-R	54	28	3.543"	5.04"	2.44"	6811550
6141312	CT-350-54-160-R	54	28	6.299"	7.80"	5.20"	6811550
6141317	CT-350-54-200-R	54	28	7.874"	9.37"	6.77"	6811550
6141322	CT-350-68-115-R	68	36	4.528"	5.94"	2.56"	6811560
6141327	CT-350-68-200-R	68	36	7.874"	8.78"	5.39"	6811560
6141332	CT-350-68-260-R	68	36	10.236"	11.14"	7.76"	6811560
6141337	CT-350-85-200-R	85	50	7.874"	8.82"	4.88"	6811570
6141342	CT-350-85-260-R	85	50	10.236"	11.18"	7.24"	6811570
6141347	CT-350-85-320-R	85	50	12.598"	13.54"	9.61"	6811570
6141352	CT-350-100-190-R	100	60	7.480"	8.43"	4.49"	6811580
6141362	CT-350-100-320-R	100	60	12.598"	13.54"	9.61"	6811580
6141357	CT-350-100-260-R	100	60	10.236"	11.18"	7.24"	6811580

Blue indicates coolant.

Blue indicates coolantFor large head toolholders, see page 188.

PinzBOHR High Precision BT30, BT40 Toolholders



Match the "d" dimension on toolholder and boring head for proper selection.

Features

- Exceed industry standards for taper accuracy and concentricity
- Two offset axial tapered locking screws maximize rigidity and allow fast tool changes
- Reducers allow different size boring heads to be used with the same toolholder

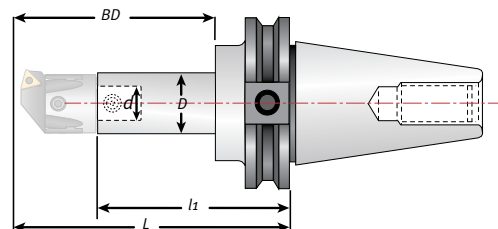

Boring depth (BD) is tool length plus boring head.

BT30 Boring Toolholders

Part-No.	Description	D (mm)	d (mm)	BD	L	l1	Coupling-Screw
6130100	BT-330-22-100	22	12	3.937"	4.92"	3.58"	6811510
6130150	BT-330-27-55	27	15	2.165"	3.03"	1.38"	6811520
6130200	BT-330-27-100	27	15	3.937"	4.92"	3.27"	6811520
6130250	BT-330-32-60	32	18	2.362"	3.27"	1.50"	6811530
6130300	BT-330-32-100	32	18	3.937"	4.92"	3.15"	6811530

BT40 Boring Toolholders

Part-No.	Description	D (mm)	d (mm)	BD	L	l1	Coupling-Screw
6140100	BT-340-22-50	22	12	1.969"	3.15"	1.81"	6811510
6140125	BT-340-22-80	22	12	3.150"	4.33"	2.99"	6811510
6140150	BT-340-22-100	22	12	3.937"	5.12"	3.78"	6811510
6140175	BT-340-27-55	27	15	2.165"	3.23"	1.57"	6811520
6140200	BT-340-27-100	27	15	3.937"	5.12"	3.46"	6811520
6140225	BT-340-27-130	27	15	5.118"	6.30"	4.65"	6811520
6140250	BT-340-32-60	32	18	2.362"	3.46"	1.69"	6811530
6140275	BT-340-32-100	32	18	3.937"	5.12"	3.35"	6811530
6140300	BT-340-32-130	32	18	5.118"	6.30"	4.53"	6811530
6140325	BT-340-42-75	42	24	2.953"	4.09"	1.89"	6811540
6140350	BT-340-42-160	42	24	6.299"	7.48"	5.28"	6811540
6140375	BT-340-42-200	42	24	7.874"	9.06"	6.85"	6811540
6140400	BT-340-54-90	54	28	3.543"	4.72"	2.13"	6811550
6140425	BT-340-54-160	54	28	6.299"	7.48"	4.88"	6811550
6140450	BT-340-54-200	54	28	7.874"	9.06"	6.46"	6811550
6140475	BT-340-68-160	68	36	6.299"	7.13"	3.74"	6811560
6140500	BT-340-68-200	68	36	7.874"	8.70"	5.31"	6811560
6140525	BT-340-85-200	85	50	7.874"	8.66"	4.72"	6811570
6140550	BT-340-100-200	100	60	7.874"	8.66"	4.72"	6811580

For large head toolholders, see page 188.



PinzBOHR High Precision BT50 Toolholders



Features

- Exceed industry standards for taper accuracy and concentricity
- Two offset axial tapered locking screws maximize rigidity and allow fast tool changes
- Reducers allow different size boring heads to be used with the same toolholder
- Use extensions to increase boring depth

Match the "d" dimension on toolholder and boring head for proper selection.



Boring
Heads
pg. 188



Inserts and
Cartridges
pg. 199



Extensions
& Reducers
pg. 213



Retention
Knobs
pg. 228

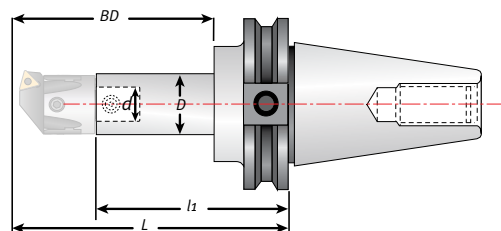

Boring depth (BD) is tool length plus boring head.

BT50 Boring Toolholders

Part No.	Description	D (mm)	d (mm)	BD	L	I1	Coupling Screw
6150100	BT-350-22-80	22	12	3.150"	4.76"	3.43"	6811510
6150125	BT-350-22-100	22	12	3.937"	5.55"	4.21"	6811510
6150150	BT-350-27-55	27	15	2.165"	3.66"	2.01"	6811520
6150175	BT-350-27-100	27	15	3.937"	5.55"	3.90"	6811520
6150200	BT-350-27-130	27	15	5.118"	6.73"	5.08"	6811520
6150225	BT-350-32-60	32	18	2.362"	3.90"	2.13"	6811530
6150250	BT-350-32-130	32	18	5.118"	6.73"	4.96"	6811530
6150275	BT-350-32-160	32	18	6.299"	7.91"	6.14"	6811530
6150300	BT-350-42-75	42	24	2.953"	4.53"	2.32"	6811540
6150325	BT-350-42-160	42	24	6.299"	7.91"	5.71"	6811540
6150350	BT-350-42-200	42	24	7.874"	9.49"	7.28"	6811540
6150375	BT-350-54-90	54	28	3.543"	5.16"	2.56"	6811550
6150400	BT-350-54-160	54	28	6.299"	7.91"	5.31"	6811550
6150425	BT-350-54-200	54	28	7.874"	9.49"	6.89"	6811550
6150450	BT-350-68-115	68	36	4.528"	6.06"	2.68"	6811560
6150475	BT-350-68-200	68	36	7.874"	9.53"	6.14"	6811560
6150500	BT-350-68-260	68	36	10.236"	11.89"	8.50"	6811560
6150525	BT-350-85-200	85	50	7.874"	9.53"	5.59"	6811570
6150550	BT-350-85-260	85	50	10.236"	11.89"	7.95"	6811570
6150575	BT-350-85-320	85	50	12.598"	14.25"	10.31"	6811570
6150600	BT-350-100-170	100	60	6.693"	7.68"	3.74"	6811580
6150625	BT-350-100-260	100	60	10.236"	11.89"	7.95"	6811580
6150650	BT-350-100-320	100	60	12.598"	14.25"	10.31"	6811580
6166123	BT-550-160*	100	60	4.921"	6.30"	2.76"	6811590

*BT-550-160 is for direct mounting of large heads. For large head toolholders, see page 188.

PinzBOHR High Precision HSK50A, 63A, 100A Toolholders



Match the d dimension on toolholder and boring head for proper selection.

Features

- Exceed industry standards for taper accuracy and concentricity
- Two offset axial tapered locking screws maximize rigidity and allow fast tool changes
- Reducers allow different size boring heads to be used with the same toolholder
- Use extensions to increase boring depth

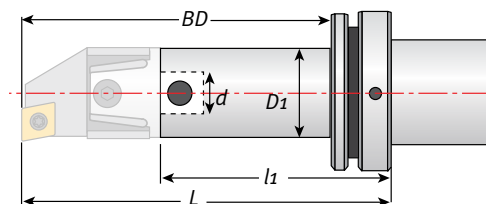

Boring depth (BD) is tool length plus boring head.

HSK50A Boring Toolholders

Part No.	Description	D1 (mm)	d (mm)	BD	L	I1	Coupling Screw
6155501	HSK-50A-22-55	22	12	2.165"	3.19"	1.85"	6811510
6155502	HSK-50A-27-65	27	15	2.559"	3.58"	1.93"	6811520
6155503	HSK-50A-32-75	32	18	2.953"	3.98"	2.20"	6811530
6155504	HSK-50A-42-90	42	24	3.543"	4.57"	2.36"	6811540

HSK63A Boring Toolholders

Part No.	Description	D1 (mm)	d (mm)	BD	L	I1	Coupling Screw
6155631	HSK-63A-22-55	22	12	2.165"	3.19"	1.85"	6811510
6155632	HSK-63A-27-65	27	15	2.559"	3.58"	1.93"	6811520
6155633	HSK-63A-32-75	32	18	2.953"	3.98"	2.20"	6811530
6155634	HSK-63A-42-90	42	24	3.543"	4.57"	2.36"	6811540
6155635	HSK-63A-54-110	54	28	4.331"	5.35"	2.76"	6811550
6155636	HSK-63A-68-145	68	36	5.709"	6.73"	3.35"	6811560

HSK100A Boring Toolholders

Part No.	Description	D1 (mm)	d (mm)	BD	L	I1	Coupling Screw
6155101	HSK-100A-22-55	22	12	2.165"	3.50"	2.165"	6811510
6155102	HSK-100A-27-65	27	15	2.559"	3.90"	2.244"	6811520
6155103	HSK-100A-32-75	32	18	2.953"	4.09"	2.322"	6811530
6155104	HSK-100A-42-90	42	24	3.543"	4.69"	2.480"	6811540
6155105	HSK-100A-54-110	54	28	4.331"	5.47"	2.847"	6811550
6155106	HSK-100A-68-145	68	36	5.709"	6.85"	3.46"	6811560
6155107	HSK-100A-85-165	85	50	6.496"	7.64"	3.70"	6811570
6155108	HSK-100A-100-185	100	60	7.283"	8.43"	4.49"	6811580
6166125	HSK-550-160*	100	60	5.511"	6.692"	3.149"	6811590

*HSK-550-160 is for direct mounting of large heads. For large head toolholders, see page 188.

PinzBOHR High Precision Weldon & R8 Toolholders



Weldon toolholder

Match the d dimension on toolholder and boring head for proper selection.

Features

- Use with any Techniks End Mill Holders with H5 bore tolerance for boring applications from .315" up to 3.228"
- Two offset axial tapered locking screws maximize rigidity and allow fast tool changes

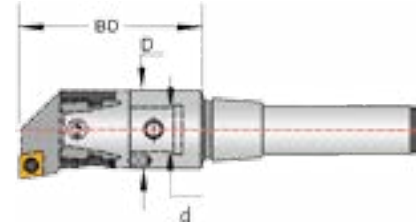

Boring depth (BD) is tool length plus boring head.

Weldon 3/4" Shank

Part No.	Description	D (mm)	d (mm)	BD	Coupling Screws
6165341	B-20-22-50-3/4-SS-WELDON	22	12	1.969"	6811510
6165342	B-20-22-100-3/4-SS-WELDON	22	12	3.937"	6811510
6165343	B-20-54-110-3/4-SS-WELDON	54	28	4.331"	6811550

Weldon 1" Shank

Part No.	Description	D (mm)	d (mm)	BD	Coupling Screws
6165101	B-25-27-55-1.0-SS-WELDON	27	15	2.165"	6811520
6165102	B-25-27-100-1.0-SS-WELDON	27	15	3.937"	6811520
6165103	B-25-54-110-1.0-SS-WELDON	54	28	4.331"	6811550

Weldon 1-1/4" Shank

Part No.	Description	D (mm)	d (mm)	BD	Coupling Screws
6165141	B-32-32-60-1-1/4-SS-WELDON	32	18	2.362"	6811530
6165142	B-32-32-100-1-1/4-SS-WELDON	32	18	3.937"	6811530
6165143	B-32-42-90-1-1/4-SS-WELDON	42	24	3.543"	6811540
6165144	B-32-54-110-1-1/4-SS-WELDON	54	28	4.331"	6811550

Weldon 1-1/2" Shank

Part No.	Description	D (mm)	d (mm)	BD	Coupling Screws
6165121	B-40-42-90-1-1/2-SS-WELDON	42	24	3.543"	6811540
6165122	B-40-42-160-1-1/2-SS-WELDON	42	24	6.299"	6811540
6165123	B-40-54-110-1-1/2-SS-WELDON	54	28	4.331"	6811550

R8 Toolholders

Part No.	Description	D (mm)	d (mm)	BD	Coupling Screws
6165801	R8-22-50-R8	22	12	1.969"	6811510
6165802	R8-27-60-R8	27	15	2.362"	6811520
6165803	R8-32-75-R8	32	18	2.953"	6811530
6165804	R8-42-90-R8	42	24	3.543"	6811540
6165805	R8-54-110-R8	54	28	4.331"	6811550



R8 Tool holder

Large Head Holders, Adapters & Extensions



Features

- Maximum rigidity and accuracy
- CAT, BT, HSK100A spindles
- Nickel-chrome alloy steel ensures best reliability and repeatability

Boring depth (BD) is tool length plus boring head.

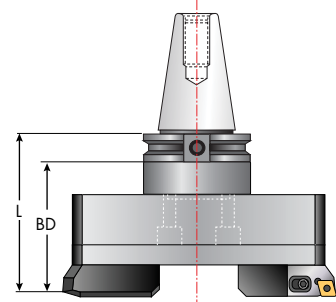

CAT, BT, HSK Direct Mount Toolholders

Part No.	Description	D	L	lbs
6166124	CAT-550-160-W	3.93"	2.75"	12.45
6166123	BT-550-160	3.93"	2.75"	13.24
6166125	HSK-550-160	3.93"	3.14"	11.55



adapter mount holders
require 6022510 adapter



optional extension



required adapter

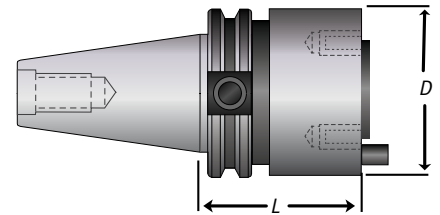

direct mount toolholder

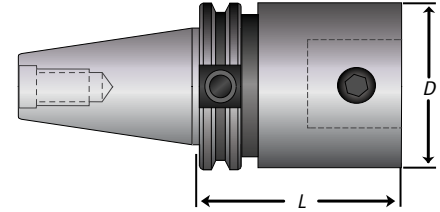

adapter mount toolholder

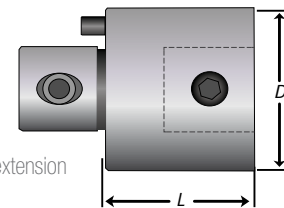

extension

CAT, BT, HSK100A Adapter Mount Toolholders

Part No.	Description	D	L	lbs
6141350	CAT-350-100-190-W	3.93"	4.48"	14.50
6141355	CAT-350-100-260-W	3.93"	7.24"	24.25
6141360	CAT-350-100-320-W	3.93"	9.60"	32.32
6150600	BT-350-100-170	3.93"	3.74"	12.74
6150625	BT-350-100-260	3.93"	7.95"	27.47
6150650	BT-350-100-320	3.93"	10.31"	35.45
6155108	HSK-100A-100-185	3.93"	4.48"	12.50

Optional Extensions (require adapter for large head mounting)

Part No.	Description	D	L	lbs
6551080	P-100-80	3.93"	3.14"	10.10
6551012	P-100-120	3.93"	4.72"	15.56

Large Head Adapter (use with adapter mount holders)

Part No.	Description	D	L	lbs
6022510	ADT-100-50	3.93"	1.96"	9.61

Extensions can be used with adaptor mount toolholders but do require a adaptor for large head mounting.

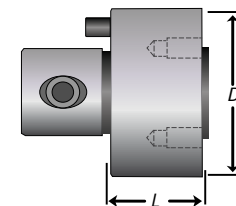

large head adapter



Large Head Mounting Instructions

Finish Heads

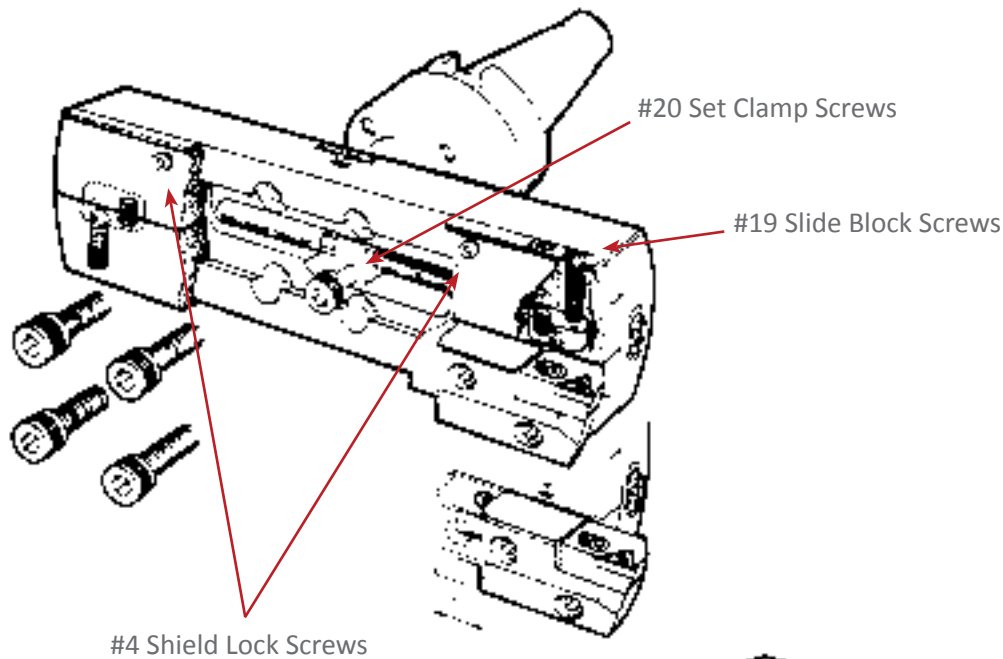

Rough Heads

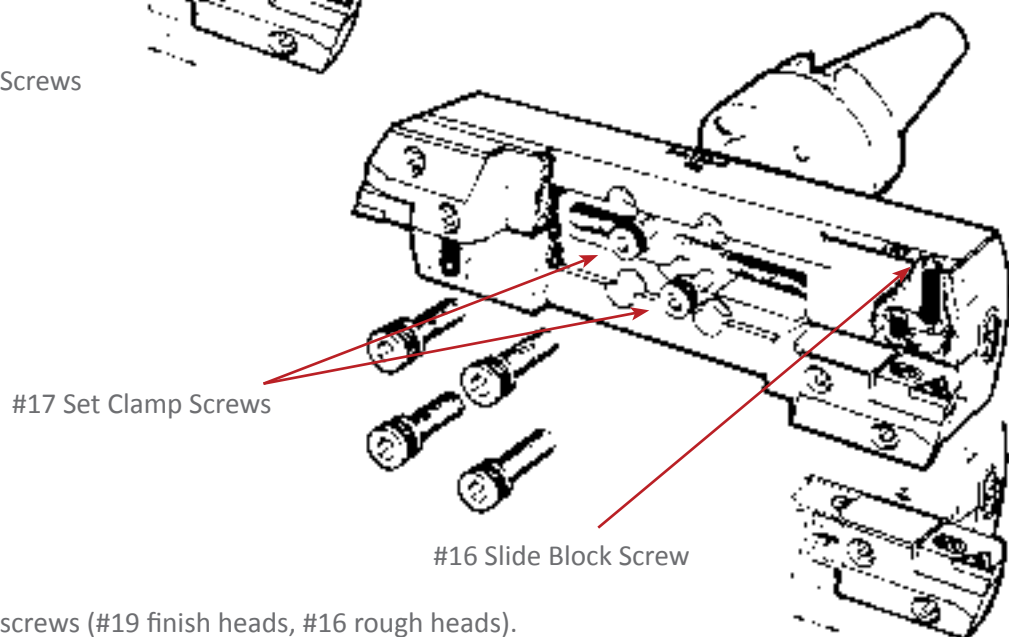

1. Loosen slide block screws (#19 finish heads, #16 rough heads).
2. Remove set clamp screws (#20 finish heads, #17 rough heads).
3. On finish boring heads only, remove shield lock screws #4.
4. Move slide blocks / shield off-center until the four counter bored bolt holes located in the body below the slide blocks are completely exposed.
5. Place taper shank holder or adapter on back side of boring head with pilot completely engaged in pilot cavity.
6. Insert 4 socket head cap screws into counter bored holes and tighten to 90 ft-lbs torque.
7. Push slide blocks back into position to line up with threaded holes below.
8. Insert nut / close shield lock screws and tighten.
9. Adjust boring head to desired diameter and tighten slide block lock screws.

PinzBOHR High Precision Extensions



Features

- Extend boring depth
- Two offset axial tapered locking screws maximize rigidity and allow fast tool changes

Match the "d" dimensions on toolholder, extension, and boring head for proper selection.

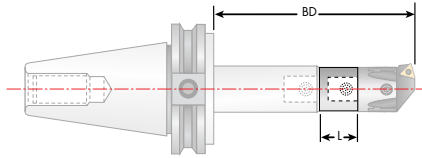

Calculate needed extension length (L) to achieve your boring depth (BD)



Boring Heads
pg. 188



Inserts and Cartridges
pg. 199



Retention Knobs
pg. 228

Standard Extensions

Part No.	Description	D (mm)	d (mm)	L	Coupling Screw
6552220	P-22-20	22	12	0.79"	6811510
6552230	P-22-30	22	12	1.18"	6811510
6552730	P-27-30	27	15	1.18"	6811520
6552745	P-27-45	27	15	1.77"	6811520
6553235	P-32-35	32	18	1.38"	6811530
6553252	P-32-52	32	18	2.05"	6811530
6554240	P-42-40	42	24	1.57"	6811540
6554260	P-42-60	42	24	2.36"	6811540
6555450	P-54-50	54	28	1.97"	6811550
6555475	P-54-75	54	28	2.95"	6811550
6556860	P-68-60	68	36	2.36"	6811560
6556890	P-68-90	68	36	3.54"	6811560
6558570	P-85-70	85	50	2.76"	6811570
6558510	P-85-105	85	50	4.13"	6811570
6551080	P-100-80	100	60	3.15"	6811580
6551012	P-100-120	100	60	4.72"	6811580

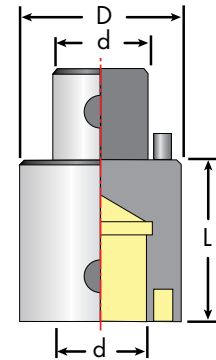

Coolant-thru Spindle Extension

Part No.	Description	D (mm)	d (mm)	L	Coupling Screw
6562230	P-22-30R	22	12	1.18"	6811510
6562730	P-27-30R	27	15	1.18"	6811520
6563235	P-32-35R	32	18	1.38"	6811530
6564240	P-42-40R	42	24	1.57"	6811540
6565450	P-54-50R	54	28	1.97"	6811550
6566860	P-68-60R	68	36	2.36"	6811560
6568570	P-85-70R	85	50	2.76"	6811570
6561080	P-100-80R	100	60	3.15"	6811580

Blue indicates coolant

Use with coolant-thru toolholders available upon request.

Coolant-thru Spindle Extension

The coolant-thru spindle extension provides coolant to the cutting zone for optimal stock removal rates.

Minimum recommend coolant pressure is 70 psi. Coolant is directed onto cutting edge by adapter.

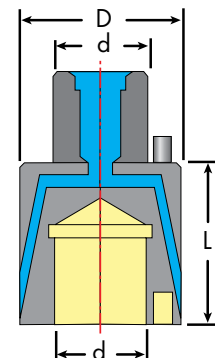

PinzBOHR High Precision Reducers & Chamfering Heads



Features

- Reducers allow different boring heads to be used with the same toolholder / extension combination
- Two offset axial tapered locking screws maximize rigidity and allow fast tool changes

Match the "d" dimensions on toolholder, reducer, and boring head for proper selection.

Reducers

Part No.	Description	D (mm)	d (mm)	D1 (mm)	d1 (mm)	L	c	Coupling Screw
6442236	R-27-22-36	27	15	22	12	1.02"	.39"	6811510
6442240	R-32-22-40	32	18	22	12	1.18"	.39"	6811510
6442258	R-42-22-58	42	24	22	12	1.89"	.39"	6811510
6442286	R-54-22-86	54	28	22	12	2.99"	.39"	6811510
6442210	R-68-22-102	68	36	22	12	3.54"	.47"	6811510
6442734	R-32-27-34	32	18	27	15	0.94"	.39"	6811520
6442750	R-42-27-50	42	24	27	15	1.57"	.39"	6811520
6442780	R-54-27-80	54	28	27	15	2.76"	.39"	6811520
6442795	R-68-27-95	68	36	27	15	3.27"	.47"	6811520
6443246	R-42-32-46	42	24	32	18	1.42"	.39"	6811530
6443276	R-54-32-76	54	28	32	18	2.60"	.39"	6811530
6443290	R-68-32-90	68	36	32	18	3.07"	.47"	6811530
6444270	R-54-42-70	54	28	42	24	2.36"	.39"	6811540
6444282	R-68-42-82	68	36	42	24	2.76"	.47"	6811540
6444295	R-85-42-95	85	50	42	24	3.27"	.47"	6811540
6445472	R-68-54-72	68	36	54	28	2.36"	.47"	6811550
6445490	R-85-54-90	85	50	54	28	3.07"	.47"	6811550
6446810	R-85-68-100	85	50	68	36	3.46"	.47"	6811560
6448510	R-100-85-100	100	60	85	50	3.46"	.47"	6811570

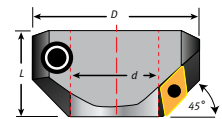
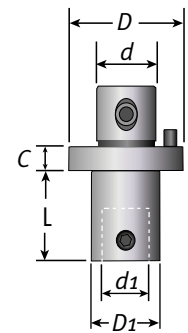

45° Chamfering Heads

Part No.	Desc.	D (mm)	d (mm)	L	Insert	Insert Screw	Wrench	Hex Wrench
6033311	CH-22	43	22	0.94"	DCMT 32.5_	6811260	9355555	4 hex
6033322	CH-27	48	27	0.94"	DCMT 32.5_	6811260	9355555	4 hex
6033333	CH-32	62	32	1.18"	DCMT 32.5_	6811260	9355555	5 hex
6033344	CH-42	72	42	1.18"	DCMT 32.5_	6811260	9355555	5 hex
6033355	CH-54	94	54	1.57"	DCMT 43_	6811266	9355666	6 hex
6033366	CH-68	110	68	1.57"	DCMT 43_	6811266	9355666	8 hex
6033377	CH-85	145	85	2.17"	DCMT 43_	6811266	9355666	10 hex
6033388	CH-100	170	100	2.36"	DCMT 43_	6811266	9355666	14 hex
6033399	CH-200	200	100	2.36"	DCMT 43_	6811266	9355666	14 hex

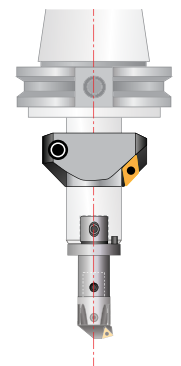

High Precision End Mill Holders & Face Mill Arbors

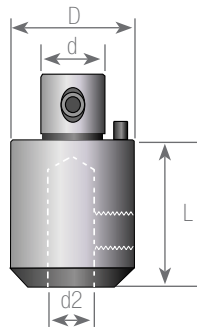

Features

- For 1/4" up to 3/4" end mills
- Use with extra-long toolholders and extensions for extended length applications
- Two offset center lock screws maximize rigidity while still permitting fast tool changes



Boring Heads
pg. 188



Inserts and Cartridges
pg. 199



Extensions & Reducers
pg. 213



Retention Knobs
pg. 228

End Mill Holders

Part No.	Description	D (mm)	d (mm)	L	d2
6123300	ADM-42-W1/4	42	24	1.38"	1/4"
6123305	ADM-42-W3/8	42	24	1.50"	3/8"
6123310	ADM-42-W1/2	42	24	2.17"	1/2"
6123315	ADM-42-W3/4	42	28	2.83"	3/4"
6123320	ADM-54-W3/4	54	28	2.85"	3/4"

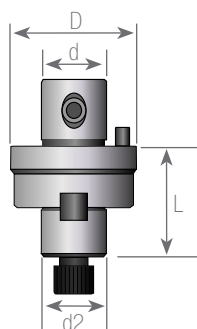

Features

- For 3/4" up to 1-1/4" face mills
- Two offset center lock screws maximize rigidity while still permitting fast tool changes
- Use with extra-long toolholders and extensions for extended length applications

Modular Coupling System

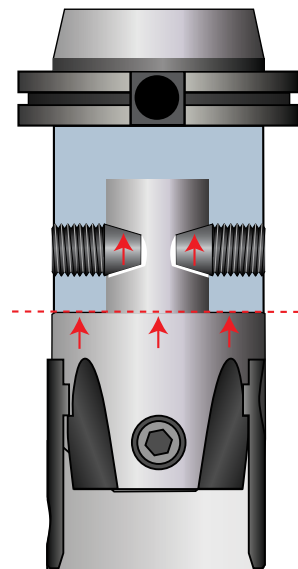

Offset Center Lock Screws

Pin and taper coupling system allows tools to be changed without removing from the spindle. Two offset center lock screws apply maximum tightening force between the tool and the toolholder. This increases rigidity and enhances vibration damping characteristics.

Face Mill Arbor

Part No.	Description	D (mm)	d (mm)	L	d2
6133300	ADM-54-3/4	54	28	1.97"	3/4"
6133305	ADM-54-1.0	54	28	1.97"	1.0"
6133310	ADM-68-1.0	68	36	1.97"	1.0"
6133315	ADM-68-1-1/4	68	36	1.97"	1-1/4"

PinzBOHR Speeds & Feeds Guidelines

Optimal speeds & feeds depend upon material, machine, tool overhang, and setup. These guidelines may not be correct for your application, but can serve as a useful starting point.

Rough Boring with Dual Inserts

Material: Plain Carbon Steel

Dia. Range (inch)	Head Size	Max. Stock Removal on Dia.	Suggested Speeds & Feeds	
			Speed SFM	Feed IPR
.944 - 1.181	22	0.38	320 - 420	.006 - .010
1.141 - 1.574	27	0.47	350 - 450	.006 - .012
1.535 - 1.968	32	0.56	350 - 500	.008 - .012
1.929 - 4.015	42, 54, 68	0.75	350 - 500	.010 - .014
3.935 - 20.00	85, 100, 200	0.84	350 - 500	.012 - .016
	300, 400, 500		350 - 500	.012 - .016

Material: Alloy Steels

.944 - 1.181	22	0.38	300 - 390	.006 - .010
1.141 - 1.574	27	0.47	320 - 420	.006 - .012
1.535 - 1.968	32	0.56	320 - 420	.008 - .012
1.929 - 4.015	42, 54, 68	0.75	320 - 420	.010 - .014
3.935 - 20.00	85, 100, 200	0.84	320 - 420	.012 - .016
	300, 400, 500		320 - 420	.012 - .016

Material: Stainless Steels

.944 - 1.181	22	0.38	200 - 300	.005 - .008
1.141 - 1.574	27	0.47	220 - 320	.006 - .010
1.535 - 1.968	32	0.56	220 - 320	.006 - .010
1.929 - 4.015	42, 54, 68	0.75	220 - 320	.008 - .012
3.935 - 20.00	85, 100, 200	0.84	220 - 320	.010 - .014
	300, 400, 500		220 - 320	.010 - .014

Material: Cast Iron

.944 - 1.181	22	0.38	200 - 350	.008 - .012
1.141 - 1.574	27	0.47	220 - 350	.010 - .014
1.535 - 1.968	32	0.56	220 - 350	.010 - .014
1.929 - 4.015	42, 54, 68	0.75	220 - 350	.012 - .016
3.935 - 20.00	85, 100, 200	0.84	220 - 350	.012 - .018
	300, 400, 500		220 - 350	.012 - .018

Material: Aluminum and Aluminum Alloys

.944 - 1.181	22	0.38	400 - 1000	.008 - .012
1.141 - 1.574	27	0.47	500 - 1200	.010 - .014
1.535 - 1.968	32	0.56	500 - 1200	.010 - .014
1.929 - 4.015	42, 54, 68	0.75	500 - 1200	.012 - .016
3.935 - 20.00	85, 100, 200	0.84	500 - 1200	.012 - .018
	300, 400, 500		500 - 1200	.012 - .018

Material: Titanium and High Temperature Alloys

.944 - 1.181	22	0.25	90 - 120	.005 - .008
1.141 - 1.574	27	0.32	100 - 130	.006 - .010
1.535 - 1.968	32	0.38	100 - 130	.006 - .010
1.929 - 4.015	42, 54, 68	0.50	100 - 130	.008 - .012
3.935 - 20.00	85, 100, 200	0.56	100 - 130	.008 - .014
	300, 400, 500		100 - 130	.008 - .014

Finish Boring with Single Inserts

Material: Plain Carbon Steel

Dia. Range (inch)	Head Size	Max. Stock Removal on Dia.	Suggested Speeds & Feeds	
			Speed SFM	Feed IPR
.944 - 1.181	22	.004 - .024	350 - 450	.002 - .006
1.141 - 1.574	27	.004 - .024	380 - 500	.002 - .006
1.535 - 1.968	32	.005 - .030	380 - 500	.002 - .006
1.929 - 4.015	42, 54, 68	.005 - .030	380 - 500	.004 - .008
3.935 - 20.00	85, 100, 200	.006 - .040	380 - 500	.004 - .008
	300, 400, 500	.006 - .040	380 - 500	.004 - .008

Material: Alloy Steels

.944 - 1.181	22	.004 - .024	320 - 420	.002 - .006
1.141 - 1.574	27	.004 - .024	350 - 450	.002 - .006
1.535 - 1.968	32	.005 - .030	350 - 480	.002 - .006
1.929 - 4.015	42, 54, 68	.005 - .030	350 - 480	.004 - .008
3.935 - 20.00	85, 100, 200	.006 - .040	350 - 480	.004 - .008
	300, 400, 500	.006 - .040	350 - 480	.004 - .008

Material: Stainless Steels

.944 - 1.181	22	.010 - .030	220 - 320	.003 - .006
1.141 - 1.574	27	.010 - .030	250 - 350	.003 - .006
1.535 - 1.968	32	.015 - .040	250 - 350	.003 - .006
1.929 - 4.015	42, 54, 68	.015 - .040	250 - 350	.004 - .008
3.935 - 20.00	85, 100, 200	.020 - .050	250 - 350	.005 - .008
	300, 400, 500	.020 - .050	250 - 350	.005 - .008

Material: Cast Iron

.944 - 1.181	22	.010 - .030	220 - 350	.003 - .006
1.141 - 1.574	27	.010 - .030	250 - 380	.003 - .006
1.535 - 1.968	32	.015 - .040	250 - 380	.003 - .006
1.929 - 4.015	42, 54, 68	.015 - .040	250 - 380	.005 - .008
3.935 - 20.00	85, 100, 200	.020 - .050	250 - 380	.005 - .008
	300, 400, 500	.020 - .050	250 - 380	.005 - .008

Material: Aluminum and Aluminum Alloys

.944 - 1.181	22	.010 - .030	500 - 1000	.002 - .006
1.141 - 1.574	27	.010 - .030	500 - 1200	.004 - .008
1.535 - 1.968	32	.015 - .040	500 - 1200	.004 - .008
1.929 - 4.015	42, 54, 68	.015 - .040	500 - 1200	.004 - .008
3.935 - 20.00	85, 100, 200	.020 - .050	500 - 1200	.004 - .010
	300, 400, 500	.020 - .050	500 - 1200	.004 - .010

Material: Titanium and High Temperature Alloys

.944 - 1.181	22	.010 - .030	100 - 130	.003 - .006
1.141 - 1.574	27	.010 - .030	100 - 150	.003 - .006
1.535 - 1.968	32	.015 - .040	100 - 150	.003 - .006
1.929 - 4.015	42, 54, 68	.015 - .040	100 - 150	.004 - .008
3.935 - 20.00	85, 100, 200	.020 - .050	100 - 150	.004 - .008
	300, 400, 500	.020 - .050	100 - 150	.004 - .008

MacroBOHR System For Large Hole Boring

Range: 8.661 to 40.157"

MacroBOHR



For finish, rough, and external boring

Easy-to-use, no complicated setups

Hard coated aluminum and nickel-chrome alloy steel for
maximum accuracy and rigidity



Built for Speed.

All Techniks products are backed by our 100% satisfaction guarantee!



MacroBOHR Boring Tools – Range: 8.661 to 40.157"

MacroBOHR Modular System



The MacroBOHR boring system is a lightweight line of tools optimized for large diameter boring.

MacroBOHR tools are capable of boring holes ranging from 8.661" up to 40.157".

All tool holders, boring heads, & counterweights are made from high-strength aluminum or nickle-chrome alloy steel. The boring heads are fully indexable on the plates and very easy to setup.

MacroBOHR Boring Range



Boring holes from 8.661" up to 40.157" can be achieved by simply changing the plate size. Each plate has 2 radial positions to locate the boring head and counter-weight to achieve minimum or maximum bore size.

Use MacroBOHR for finish, rough, and external boring applications. External boring is achieved by reversing the cartridge position.

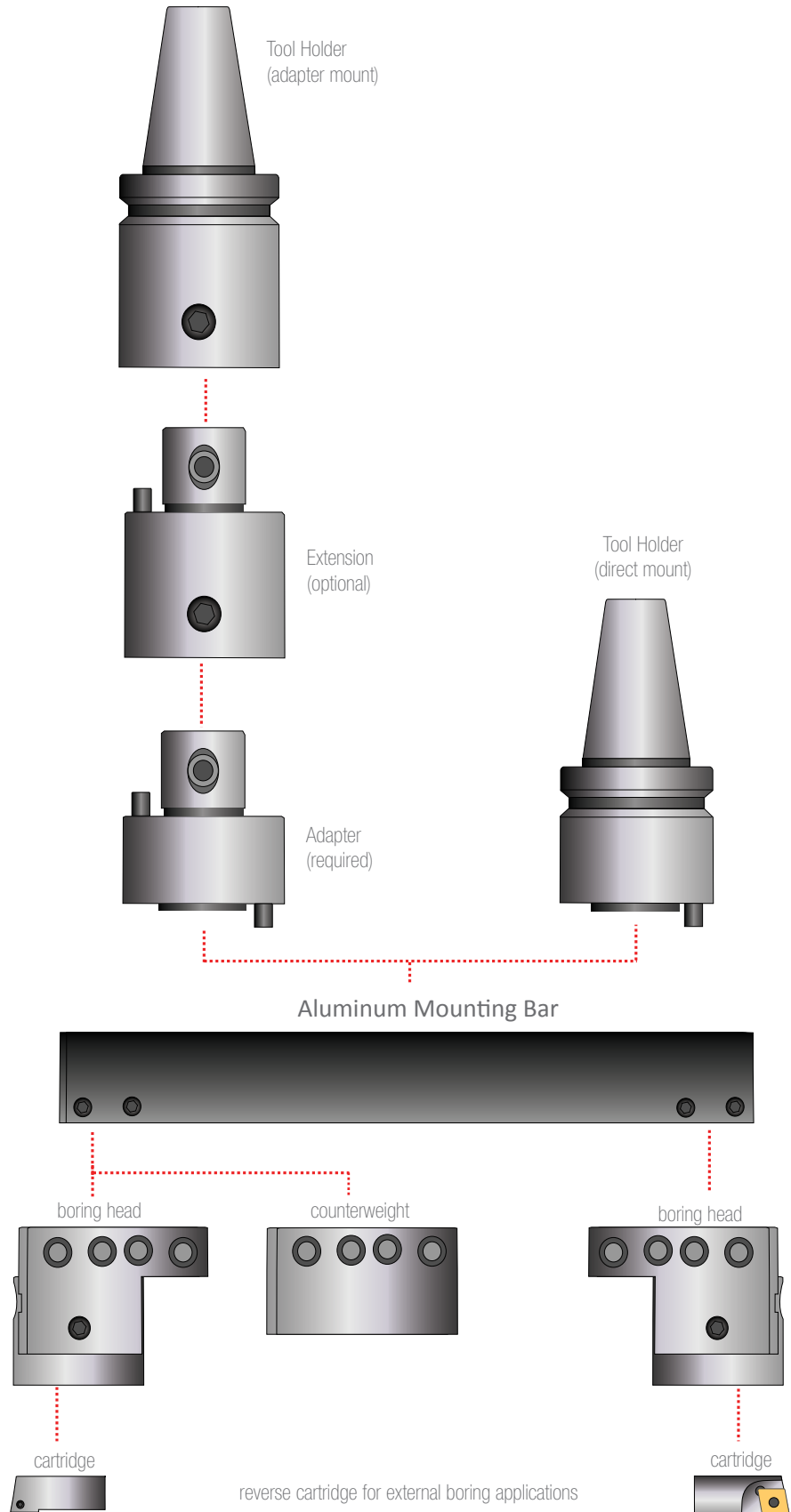

MacroBOHR Plates, Boring Heads, Cartridges & Counterweights

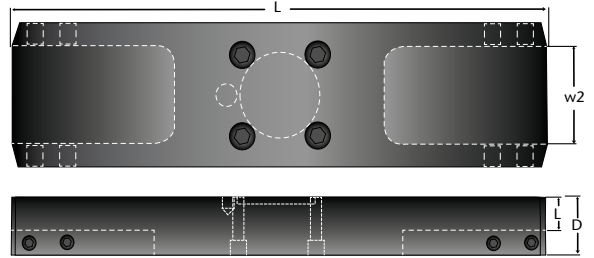

Aluminum Mounting Bars

Part No.	Description	Min	Max	L	w2	D	L	lbs	Coupling screw	Qty.	Fixing Screw	Qty.
6921255	MB-SP-0320	8.66"	12.59"	7.87"	3.93"	2.28"	1.22"	4.76	TF 100	4	TC-068-1624	8
6921256	MB-SP-0420	12.59"	16.53"	11.81"	3.93"	2.28"	1.22"	7.21	TF 100	4	TC-068-1624	8
6921257	MB-SP-0520	16.53"	20.47"	15.74"	3.93"	2.28"	1.22"	11.46	TF 101	4	TC-068-1624	8
6921258	MB-SP-0620	20.47"	24.40"	19.68"	3.93"	2.67"	1.61"	18.08	TF 102	4	TC-068-1624	8
6921259	MB-SP-0720	24.40"	28.34"	23.62"	3.93"	2.67"	1.61"	22.27	TF 102	4	TC-068-1624	8
6921260	MB-SP-0820	28.34"	32.28"	27.55"	3.93"	2.67"	1.61"	26.24	TF 102	4	TC-068-1624	8
6921261	MB-SP-0920	32.28"	36.22"	31.49"	3.93"	3.07"	2.00"	35.27	TF 103	4	TC-068-1624	8
6921262	MB-SP-1020	36.22"	40.15"	35.43"	3.93"	3.07"	2.00"	39.90	TF 103	4	TC-068-1624	8



AccuSET graduated dial in .0001" increments for fast and easy cutting adjustments.

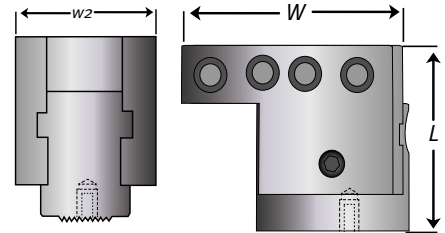

Boring Head

Part No.	Description	W	L	w2	lbs	Cartridge Screw	Adjusting Key	Locking Key
6390410	MB-068-W	4.07"	3.42"	2.67"	6.77	CS 10 25	HK 050	HK 080

Cartridges



Part No.	Description	Insert	W	L	lbs	Torx Screw	Torx Key
6690190	TP_22_	TP-1102	2.00"	.78"	0.22	TT 400	TK 08
6922243	TC_32.5_	TC-16T3	2.00"	.78"	0.22	TT 409	TK 15
6921234	CC_32.5_	CC-09T3	2.00"	.78"	0.22	TT 409	TK 15

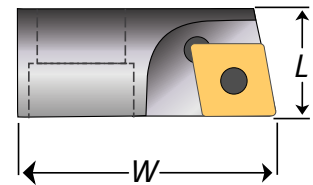

Counterweight



Part No.	Description	W	L	lbs
6921245	MB-CW	4.07"	2.36"	6.99

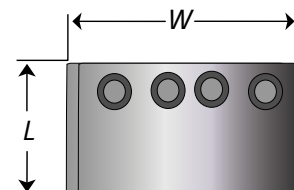

MacroBOHR Holders, Adapters & Extensions



Features

- Maximum rigidity and accuracy
- CAT, BT, HSK100A spindles
- Nickel-chrome alloy steel ensures best reliability and repeatability

CAT, BT, HSK Direct Mount Toolholders

Part No.	Description	D	L	lbs
6166124	CAT-550-160-W	3.93"	2.75"	12.45
6166123	BT-550-160	3.93"	2.75"	13.24
6166125	HSK-550-160	3.93"	3.14"	11.55

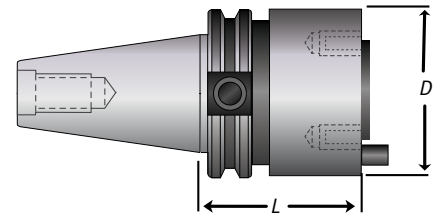

direct mount toolholders do not accept extensions.



adapter mount holders require 6022510 adapter



optional extension



required adapter

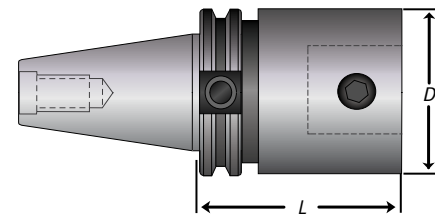

adapter mount toolholder

CAT, BT, HSK100A Adapter Mount Toolholders

Part No.	Description	D	L	lbs
6141350	CAT-350-100-190-W	3.93"	4.48"	14.50
6141355	CAT-350-100-260-W	3.93"	7.24"	24.25
6141360	CAT-350-100-320-W	3.93"	9.60"	32.32
6150600	BT-350-100-170	3.93"	3.74"	12.74
6150625	BT-350-100-260	3.93"	7.95"	27.47
6150650	BT-350-100-320	3.93"	10.31"	35.45
6155108	HSK-100A-100-185	3.93"	4.48"	12.50

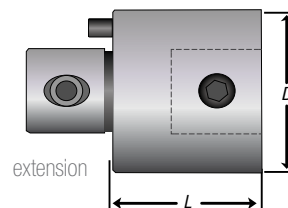

extension

Optional Extensions (require adapter for large head mounting)

Part No.	Description	D	L	lbs
6551080	P-100-80	3.93"	3.14"	10.10
6551012	P-100-120	3.93"	4.72"	15.56

Extensions can be used with adaptor mount toolholders but do require a adaptor for large head mounting.

Large Head Adapter (use with adapter mount holders)

Part No.	Description	D	L	lbs
6022510	ADT-100-50	3.93"	1.96"	9.61

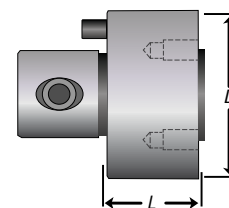

large head adapter

Parts for Rough Heads

Indexable cartridges and insert screws are on page 176.

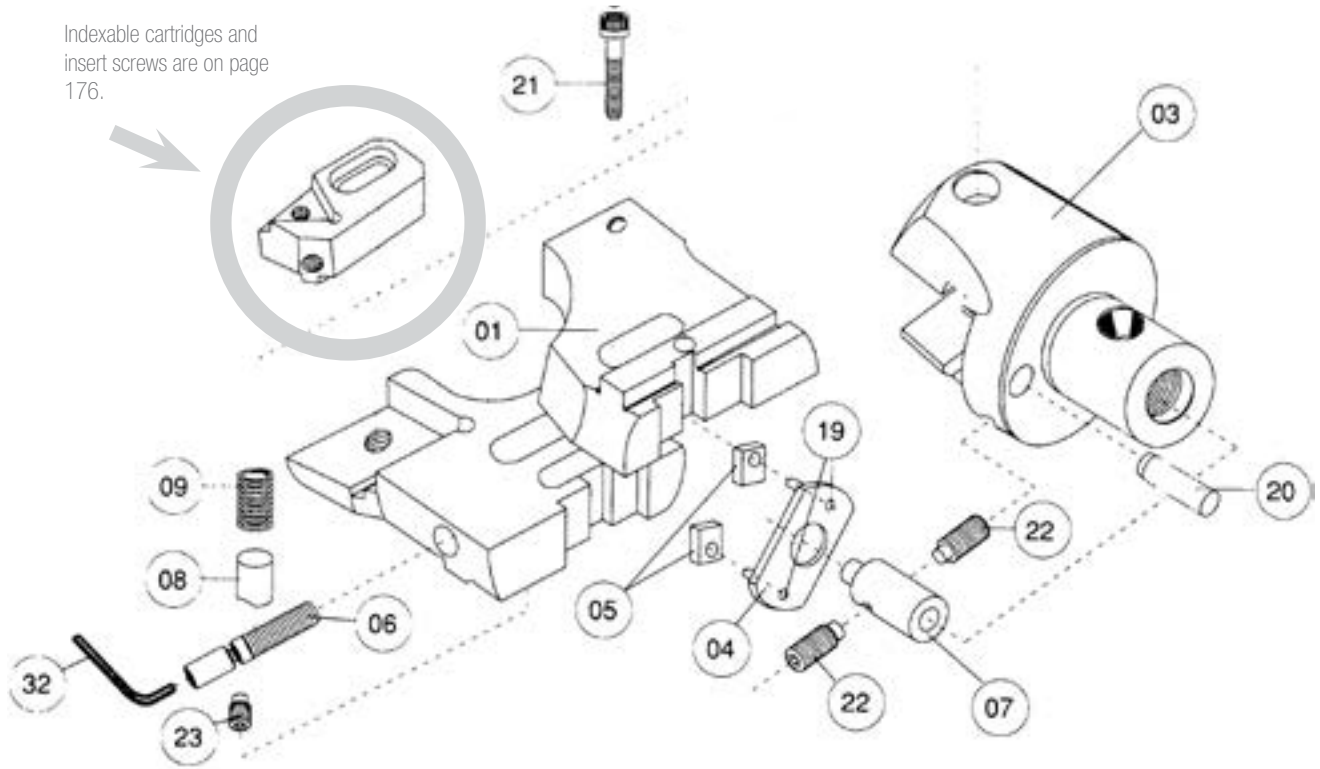

Rough Boring Heads - Integral Pocket

Boring Heads	01	03	04	05	06	07	08	09	19	20	21	22	23
D 22.75_ _ _	D22.75.01._ _ _	D22 03	D22 04		D22 06	D22 07	D22 08	D22 09	D22 19	D22 20	D22 21	D22 22	D22 23
D 22.90_ _ _	D22.90.01._ _ _	D22 03	D22 04		D22 06	D22 07	D22 08	D22 09	D22 19	D22 20	D22 21	D22 22	D22 23
D 27.75_ _ _	D27.75.01._ _ _	D27 03	D27 04		D27 06	D22 07	D22 08	D27 09	D22 19	D27 20	D27 21	D27 22	D27 23
D 27.90_ _ _	D27.90.01._ _ _	D27 03	D27 04		D27 06	D22 07	D22 08	D27 09	D22 19	D27 20	D27 21	D27 22	D27 23
D 32.75_ _ _W	D32.75.01._ _ _	D32 03W	D32 04		D32 06	D32 07	D32 08	D32 09	D32 19	D32 20	D32 21	D32 22	D32 23
D 32.90_ _ _W	D32.90.01._ _ _	D32 03W	D32 04		D32 06	D32 07	D32 08	D32 09	D32 19	D32 20	D32 21	D32 22	D32 23
D 42.75_ _ _	D42.75.01._ _ _	D42 03	D42 04	D42 05	D42 06	D42 07	D42 08	D42 09	D22 20	D42 20	D42 21	D42 22	D42 23
D 42.90_ _ _	D42.90.01._ _ _	D42 03	D42 04	D42 05	D42 06	D42 07	D42 08	D42 09	D22 20	D42 20	D42 21	D42 22	D42 23
D 54.75_ _ _	D54.75.01._ _ _	D54 03	D54 04	D42 05	D54 06	D54 07	D54 08	D42 09	D22 20	D54 20	D54 21	D54 22	D42 23
D 54.90_ _ _	D54.90.01._ _ _	D54 03	D54 04	D42 05	D54 06	D54 07	D54 08	D42 09	D22 20	D54 20	D54 21	D54 22	D42 23

Rough Boring Heads - Cartridge Type

Boring Heads	01	03	04	05	06	07	08	09	19	20	21	22	23
D 68.2CT_ _ _	D68 01 2CT	D68 03	D68 04	D68 05	D68 06	D68 07	D68 08	D68 09	D68 19	D68 20	D68 21	D68 22	D68 23
D 85.3CT_ _ _	D85 01 3CT	D85 03	D85 04	D85 05	D85 06	D85 07	D85 08	D85 09	D85 19	D85 20	D85 21	D85 22	D85 23
D 100.3CT_ _ _	D100 01 3CT	D100 03	D100 04	D85 05	D100 06	D100 07	D100 08	D85 09	D85 19	D100 20	D100 21	D85 22	D85 23
D 200.3CT_ _ _	D200 01 3CT	D200 03	D100 04	D85 05	D200 06	D100 07	D100 08	D85 09	D85 19	D100 20	D100 21	D85 22	D85 23

Parts for Large Rough Heads

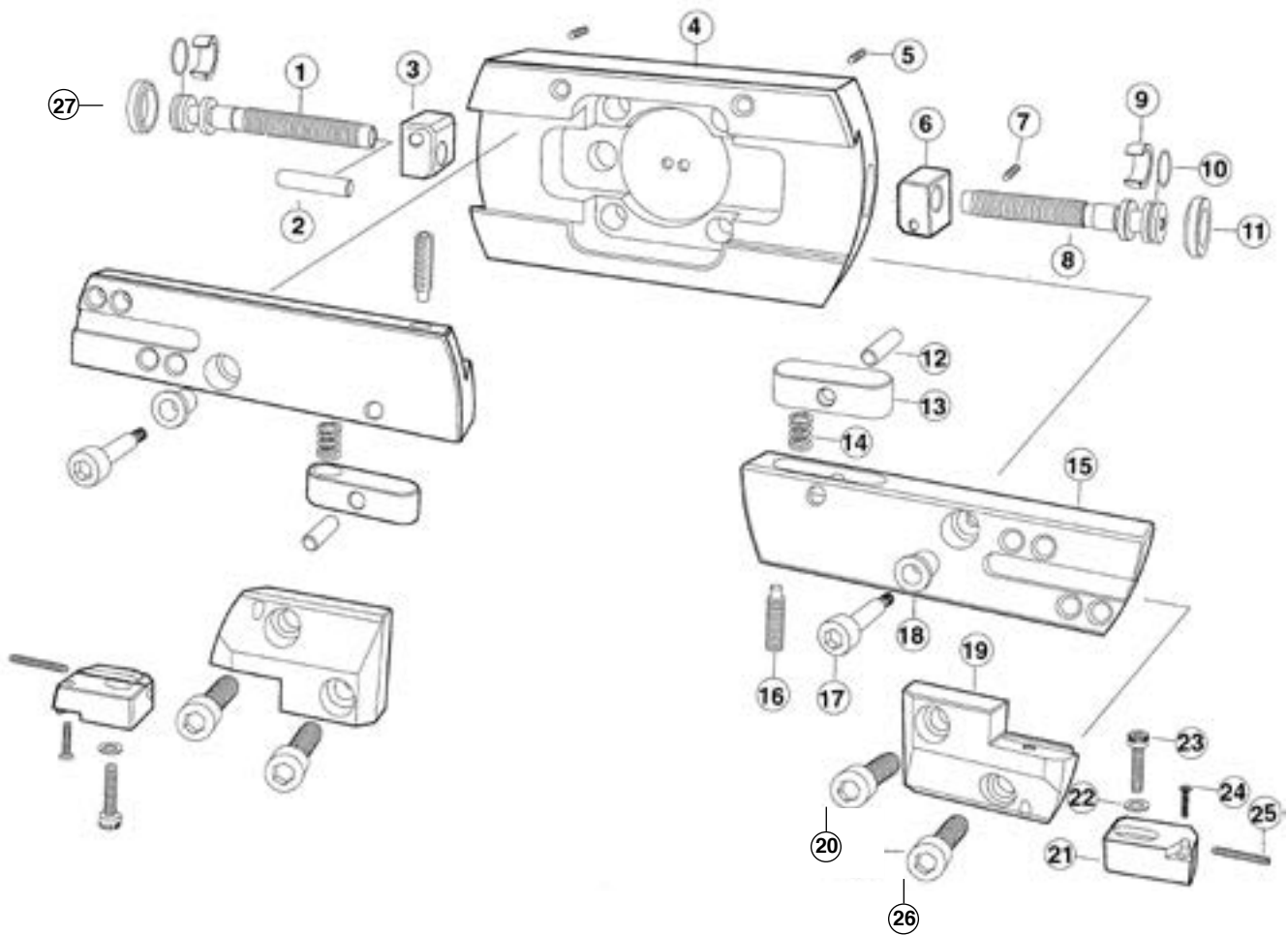

Large Rough Boring Heads

Spare Part	Rough Head Reference Number		
	D 300W	D 400W	D 500W
1	D300.51W	D400.51W	D500.51W
2	D300.66	D300.66	D300.66
3	D300.55W	D300.55W	D300.55W
4	D300.03	D400.03	D500.03
5	D68.23	D68.23	D68.23
6	D300.54W	D300.54W	D300.54W
7	D300.65	D300.65	D300.65
8	D300.50W	D400.50W	D500.50W
9	A68.16	A68.16	A68.16
10	A68.25	A68.25	A68.25
11	D300.15	D300.15	D300.15
12	D300.60	D300.60	D300.60
13	D300.56	D300.56	D300.56

Spare Part	Rough Head Reference Number		
	D 300W	D 400W	D 500W
14	D300.59	D300.59	D300.59
15	D300.01	D400.01	D500.01
16	D300.58	D300.58	D300.58
17	D300.57	D300.57	D300.57
18	D300.62	D300.62	D300.62
19	D300.49	D300.49	D300.49
20	D300.61	D300.61	D300.61
21	3CT. _ _ _ _	3CT. _ _ _ _	3CT. _ _ _ _
22	D68.28	D68.28	D68.28
23	D85.27	D85.27	D85.27
24	TT _ _ _ _	TT _ _ _ _	TT _ _ _ _
25	D85.29	D85.29	D85.29
26	D300.67	D300.67	D300.67
27	A68.15	A68.15	A68.15

Parts for Finish Heads

Indexable cartridges and insert screws are on page 176.

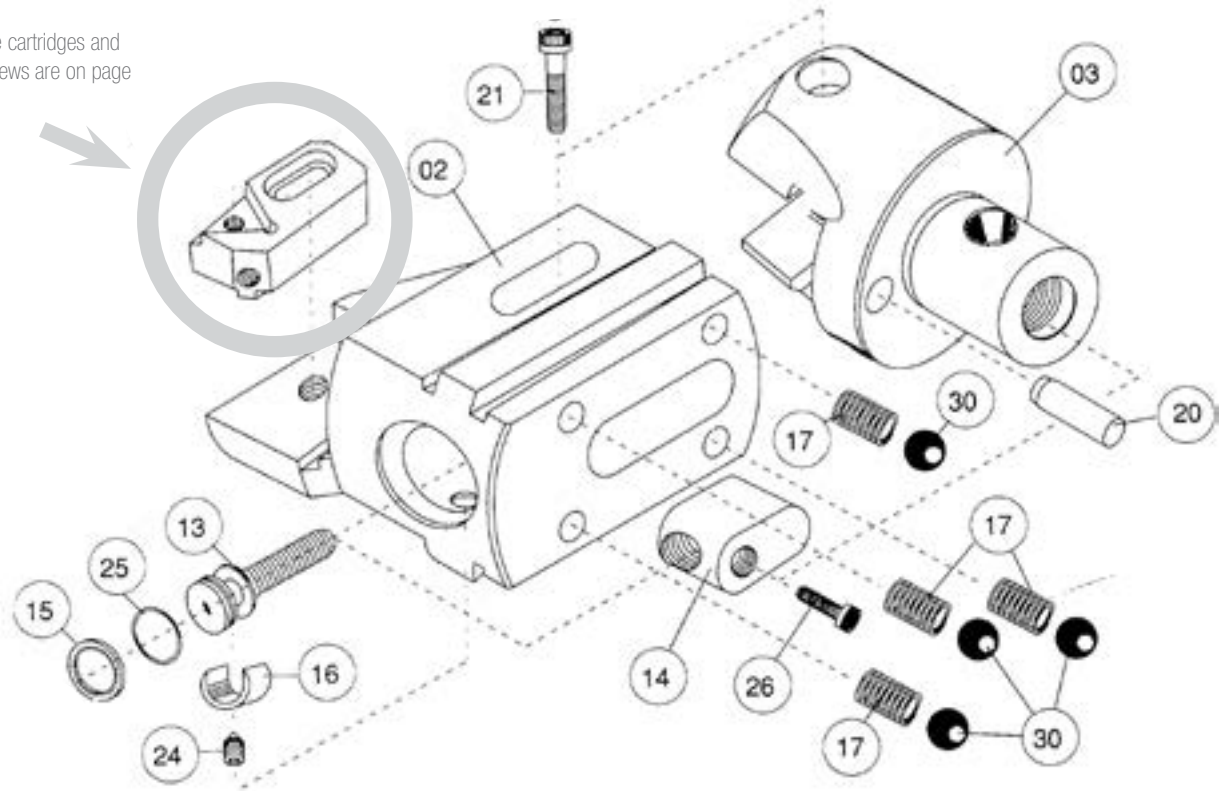

Finish boring heads - Integral Pocket

Boring Head	02	03	13	14	15	16	17	20	21	24	25	26	30
A 22.75__W	A22.75.02__	A22 03	A22 13W	A22 14W	A22 15	A22 16	A22 17	D22 20	D22 21	D22 23	A22 25	A22 26	A22 30
A 22.90__W	A22.90.02__	A22 03	A22 13W	A22 14W	A22 15	A22 16	A22 17	D22 20	D22 21	D22 23	A22 25	A22 26	A22 30
A 27.75__W	A27.75.02__	A27 03	A27 13W	A22 14W	A22 15	A22 16	A27 17	D27 20	D27 21	D27 23	A22 25	A27 26	A27 30
A 27.90__W	A27.90.02__	A27 03	A27 13W	A22 14W	A22 15	A22 16	A27 17	D27 20	D27 21	D27 23	A22 25	A27 26	A27 30
A 32.75__W	A32.75.02__	A32 03W	A32 13W	A32 14W	A32 15	A32 16	A27 17	D32 20	D32 21	D32 23	A22 25	A32 26	A27 30
A 32.90__W	A32.90.02__	A32 03W	A32 13W	A32 14W	A32 15	A32 16	A27 17	D32 20	D32 21	D32 23	A22 25	A32 26	A27 30
A 42.75__W	A42.75.02__	A42 03	A42 13W	A42 14W	A42 15	A42 16	A42 17	D42 20	D42 21	D42 23	A42 25	A42 26	A42 30
A 42.90__W	A42.90.02__	A42 03	A42 13W	A42 14W	A42 15	A42 16	A42 17	D42 20	D42 21	D42 23	A42 25	A42 26	A42 30
A 54.75__W	A54.75.02__	A54 03	A54 13W	A54 14W	A42 15	A42 16	D42 09	D54 20	D54 21	D42 23	A42 25	A42 26	A54 30
A 54.90__W	A54.90.02__	A54 03	A54 13W	A54 14W	A42 15	A42 16	D42 09	D54 20	D54 21	D42 23	A42 25	A42 26	A54 30

Finish Boring Heads - Cartridge Type

Boring Head	02	03	13	14	15	16	17	20	21	24	25	26	30
A 68.2CT__W	A68 02 2CT	A68 03	A68 13W	A68 14W	A68 15	A68 16	A68 17	D68 20	D68 21	D68 23	A68 25	A68 26	A68 30
A 85.3CT__W	A85 02 3CT	A85 03	A85 13W	A85 14W	A85 15	A85 16	D85 09	D85 20	D85 21	D85 23	A85 25	A85 26	A85 30
A 100.3CT__W	A100 02 3CT	A100 03	A85 13W	A85 14W	A85 15	A85 16	D85 09	D100 20	D100 21	D85 23	A85 25	A85 26	A85 30
A 200.3CT__W	A200 02 3CT	A200 03	A200 13W	A85 14W	A85 15	A85 16	D85 09	D100 20	D100 21	D85 23	A85 25	A85 26	A85 30

Parts for Large Finish Heads

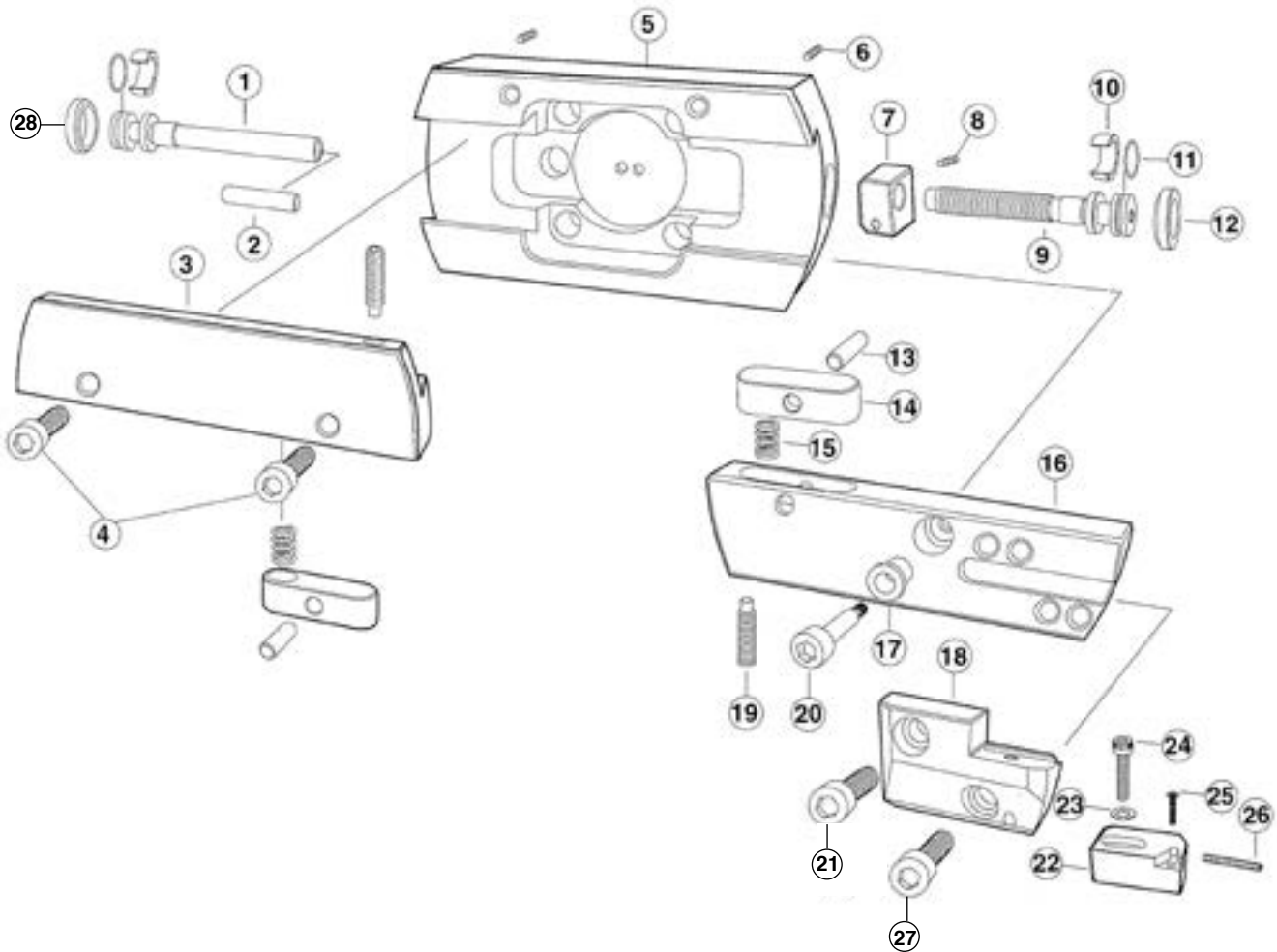

Large Finish Boring Heads

Spare Part	Finish Head Reference Number		
	A 300W	A 400W	A 500W
1	A300.52W	A300.52W	A300.52W
2	D 300.66	D 300.66	D 300.66
3	A 300.02	A400.02	A500.02
4	A300.63	A300.63	A300.63
5	D300.03	D400.03	D500.03
6	D68.23	D68.23	D68.23
7	D300.54W	D300.54W	D300.54W
8	D300.65	D300.65	D300.65
9	D300.50W	D300.50W	D300.50W
10	A68.16	A68.16	A68.16
11	A68.25	A68.25	A68.25
12	D300.15	D300.15	D300.15
13	D300.60	D300.60	D300.60
14	D300.56	D300.56	D300.56

Spare Part	Finish Head Reference Number		
	A 300W	A 400W	A 500W
15	D300.59	D300.59	D300.59
16	D300.001	D400.001	D500.001
17	D300.62	D300.62	D300.62
18	D300.49	D300.49	D300.49
19	D300.58	D300.58	D300.58
20	D300.57	D300.57	D300.57
21	D300.61	D300.61	D300.61
22	3CT. _ _ _ _	3CT. _ _ _ _	3CT. _ _ _ _
23	D68.28	D68.28	D68.28
24	D85.27	D85.27	D85.27
25	TT _ _ _ _	TT _ _ _ _	TT _ _ _ _
26	D85.29	D85.29	D85.29
27	D300.67	D300.67	D300.67
28	A68.15	A68.15	A68.15

PinzBOHR Boring Tool Selection Guide

Use the questions below to determine your tooling requirements. You can also fill out and fax this information to us if you need assistance with your tooling selection. Fax it to: (317) 803-8001.

Name _____

Company _____

Address _____

City _____ St _____ Zip _____

E-mail _____ Ph _____ Fax _____

1. What is the finish size of the hole? _____

(Determines size of boring head.)

2. What is the tolerance of the finished hole? _____

(Determines if you need rough or finish boring head.)

3. Is the starting hole forged, cast, drilled, or reamed? _____

(Determines whether you need 75 or 90 degree boring head.)

4. What is the design of the bored hole? _____

(Also determines degree of boring head.)

a. Stepped bore

b. Thru bore _____

5. What material are you machining? _____

(Determines insert grade and chip breaker selection.)

6. What spindle type is on the machine? _____

(Determines holder selection.)

7. How deep is the bore? _____

(Determines length of holder and extensions.)

8. Do you require any extra reach for fixturing or other reasons? _____

9. Does your machine have coolant-thru capability? _____

Misc: Select coolant option based on connection diameter and bore depth requirements (question #6 above).



Key to boring head descriptions

- A 22 75 400** A = finish heads, D = rough heads (see question #2 above)
22 = connection diameter (see question #1 above)
75 = approach angle (see question #3 above)
400 = insert style or CT cartridge (see question #5 above)



Key to boring toolholder descriptions

- CT 330 or 350 22 100**
CT = type of spindle (see question #6 above)
330 = taper size (see question #6 above)
22 = connection diameter (match head connection)
100 = boring depth (BD) (see question #7 above)

Precision Retention Knobs & Setup Equipment



Retention Knobs

- *Manufactured to the highest standards and hand inspected for quality*
- *All mating surfaces are precision ground for maximum safety and long life*

Tightening Fixtures

- *Preset tools offline to save machine time*
- *For CAT, BT, HSK, ISO tapers*
- *Change retention knobs from below*



Fits C5, C6
(pg. 234)



Adjustable Torque Wrenches and Adapters

<http://ow.ly/rloj1>
View the video on testing runout.



You lose 10% of tool life for every .0001" of T.I.R.
Techniks End Mill holders are manufactured to an
H5 bore tolerance to extend cutting tool life.



Built for Speed.

All Techniks products are backed by our 100% satisfaction guarantee!

CAT40, 50 Precision Retention Knobs



CAT Retention Knobs

Techniks Retention Knobs

- All mating surfaces precision ground
- Manufactured to the highest standards for maximum safety and long life
- Hardened for maximum longevity

Please make sure that the Retention Knob you order is the correct one for your machine. Using the wrong Retention Knob can cause damage to your machine spindle, the toolholder, and may create a safety hazard.

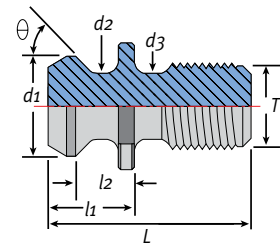

ANSI Style

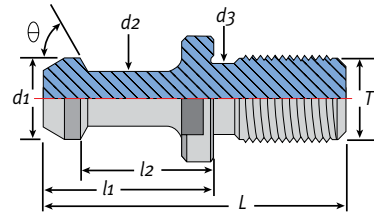

MAS Style

Part No.	Type	θ	d1	d2	d3	L	I1	I2	T
21006-15	CAT40-DIN	15°	.75"	0.55"	0.640"	1.88"	1.024"	.787"	5/8 - 11
21007-15	CAT40-DIN	15°	.75"	0.55"	-	1.89"	1.028"	.792"	5/8 - 11
21003	CAT40-ANSI	45°	0.740"	0.490"	0.490"	1.50"	0.640"	.440"	5/8 - 11
21003-45	CAT40-MAS-I	45°	0.590"	0.394"	0.512"	2.25"	1.266"	.990"	5/8 - 11
21003-60	CAT40-MAS-II	60°	0.590"	0.394"	0.512"	2.25"	1.266"	.990"	5/8 - 11
21003-90	CAT40-MAS-III	90°	0.590"	0.394"	0.512"	2.25"	1.266"	.990"	5/8 - 11
21005-45	CAT50-MAS-I	45°	0.906"	0.669"	0.827"	3.346"	1.772"	1.378"	1 - 8
21005-60	CAT50-MAS-II	60°	0.906"	0.669"	0.827"	3.346"	1.772"	1.378"	1 - 8
21005-90	CAT50-MAS-III	90°	0.906"	0.669"	0.827"	3.346"	1.772"	1.378"	1 - 8
21008-15	CAT50-DIN	15°	1.101"	0.825"	-	2.640"	1.338"	.984"	1 - 8
21005	CAT50-ANSI	45°	1.140"	0.820"	0.820"	2.30"	1.00"	.700"	1 - 8

CAT Coolant Style Retention Knobs

Part No.	Type	θ	d1	d2	d3	L	I1	I2	T
17836	CAT40, ANSI, w/ metric thread	45°	.74"	0.49"	0.49"	1.50"	0.63"	0.56"	M16x2
21006-15C	CAT40-DIN Coolant	15°	.75"	0.55"	0.640"	1.88"	1.024"	.787"	5/8 - 11
21007-15C	CAT40-DIN Coolant	15°	.75"	0.55"	-	1.89"	1.028"	.792"	5/8 - 11
21148-C	CAT40-Coolant Mori-Seiki	15°	0.747"	0.548"	0.641"	2.004"	1.024"	.787"	5/8 - 11
21003-C	CAT40-ANSI-C	45°	0.740"	0.490"	0.490"	1.50"	0.640"	.440"	5/8 - 11
21003-45C	CAT40-Coolant-I	45°	0.590"	0.394"	0.512"	2.25"	1.266"	.990"	5/8 - 11
21003-60C	CAT40-Coolant-II	60°	0.590"	0.394"	0.512"	2.25"	1.266"	.990"	5/8 - 11
21003-90C	CAT40-Coolant-III	90°	0.590"	0.394"	0.512"	2.25"	1.266"	.990"	5/8 - 11
21003-45CSF	CAT40-Coolant-I SlimFIT	45°	0.590"	0.394"	0.512"	2.25"	1.266"	.990"	5/8 - 11
21003-60CSF	CAT40-Coolant-II SlimFIT	60°	0.590"	0.394"	0.512"	2.25"	1.266"	.990"	5/8 - 11
21003-90CSF	CAT40-Coolant-III SlimFIT	90°	0.590"	0.394"	0.512"	2.25"	1.266"	.990"	5/8 - 11
21005-45C	CAT50-Coolant-I	45°	0.906"	0.669"	0.827"	3.346"	1.772"	1.378"	1 - 8
21005-60C	CAT50-Coolant-II	60°	0.906"	0.669"	0.827"	3.346"	1.772"	1.378"	1 - 8
21005-90C	CAT50-Coolant-III	90°	0.906"	0.669"	0.827"	3.346"	1.772"	1.378"	1 - 8
21008-15C	CAT50-DIN Coolant	15°	1.101"	0.825"	-	2.640"	1.338"	.984"	1 - 8
21005-C	CAT50-ANSI-C	45°	1.140"	0.820"	0.820"	2.30"	1.00"	.700"	1 - 8

BT Retention Knobs



Techniks Retention Knobs

- All mating surfaces precision ground
- Manufactured to the highest standards for maximum safety and long life
- Hardened for maximum longevity

Please make sure that the Retention Knob you order is the correct one for your machine. Using the wrong Retention Knob can cause damage to your machine spindle, the toolholder, and may create a safety hazard.

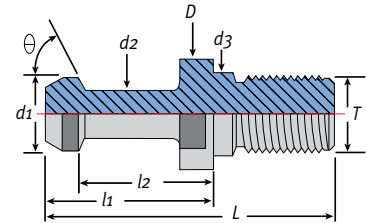

BT Retention Knobs

Dimensions in millimeters.

Part No.	Description	θ	D	d1	d2	d3	L	l1	l2	T
17801	BT30 - 45°	45°	16.5	11	7	12.5	43	23	18	M12
17803	BT40 - 45°	45°	23	15	10	17	60	35	28	M16
17834	BT40, ANSI, metric thread	45°	23	18.8	12.5	12.4	38	16	11	M16
17805	BT50 - 45°	45°	38	23	17	25	85	45	35	M24
17806	BT30 - 60°	60°	16.5	11	7	12.5	43	23	18	M12
17808	BT40 - 60°	60°	23	15	10	17	60	35	28	M16
17810	BT50 - 60°	60°	38	23	17	25	85	45	35	M24
17812	BT30 - 90°	90°	16.5	11	7	12.5	43	23	8	M12
17814	BT40 - 90°	90°	23	15	10	17	60	35	28	M16
17816	BT50 - 90°	90°	38	23	17	25	85	45	35	M24

BT Coolant Style Retention Knobs

Dimensions in millimeters.

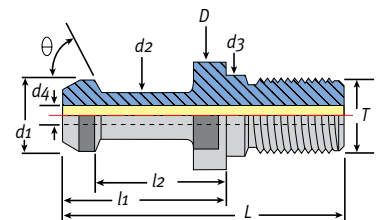

Part No.	Description	θ	D	d1	d2	d3	d4	L	l1	l2	T
17817	BT30 - 45° coolant	45°	16.5	11	7	12.5	4	43	23	18	M12
17818	BT40 - 45° coolant	45°	23	15	10	17	4	60	35	28	M16
17820	BT40 - 60° coolant	60°	23	15	10	17	4	60	35	28	M16
17822	BT40 - 90° coolant	90°	23	15	10	17	4	60	35	28	M16
17824	BT50 - 45° coolant	45°	38	23	17	25	5	85	45	35	M24
17826	BT50 - 60° coolant	60°	38	23	17	25	5	85	45	35	M24
17828	BT50 - 90° coolant	90°	38	23	17	25	5	85	45	35	M24

Retention Knobs for CNC Routers



- All mating surfaces precision ground
- Manufactured to the highest standards for maximum safety and long life
- Hardened for maximum longevity

Match the dimensions and appearance of your retention knob to the drawings below. Use the manufacturer's print that came with your machine to verify your selection.

For safe operation, make sure that the pull stud you order is the exact pull stud your machine uses. Using the wrong pull stud can cause damage to the spindle and/or toolholder, and is a safety hazard.

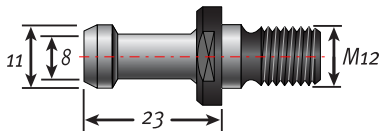

BT30 – 45°

Part No. 07801
Includes: Heian, Shinx

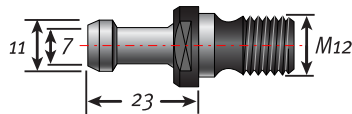

BT30 – 60°

Part No. 07806
Includes: Shoda, Anderson (1997 and earlier, verify on manufacturer's print)

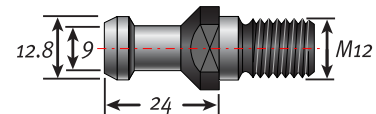

BT30 KOMO

Part No. 750-19
Only for BT30 KOMO routers

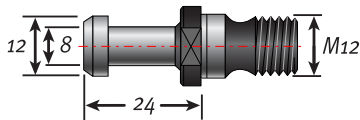

BT30 – 90°

Part No. 07812
(verify on manufacturer's print)

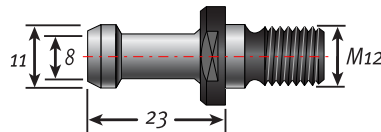

BT35 – 60°

Part No. 4403502
(Heian, verify on manufacturer's print)

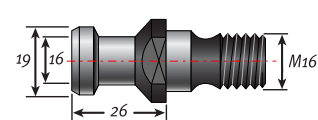

DAT 40

Part No. 49003
(verify on manufacturer's print)

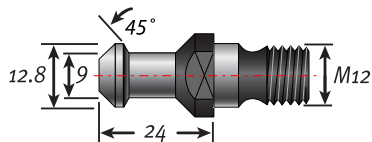

Colombo ISO30 Ball Style for RS Spindles

Part No. 49001-45
Includes: Motion Master
(verify on manufacturer's print)

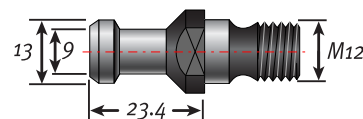

For Colombo ISO30 for Billet Spindle

Part No. 49001
Includes: Motion Master, Anderson
(for newer machines, verify on manufacturer's print)

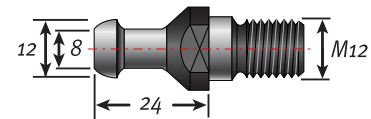

ISO30 For HSD Spindles

Part No. 49019
Includes: Biesse, Bermag, Bussellato, CNT, DMS, CR Onsrud, Masterwood, Thermwood, and Holz-her

DIN 69871 A & B Retention Knobs & Calibration Tools



Techniks Retention Knobs

- All mating surfaces precision ground
- Manufactured to the highest standards for maximum safety and long life
- Hardened for maximum longevity

Please make sure that the Retention Knob you order is the correct one for your machine. Using the wrong Retention Knob can cause damage to your machine spindle, the toolholder, and may create a safety hazard.

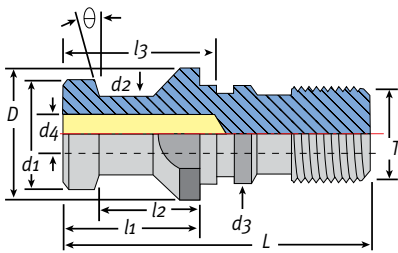

DIN 69871B

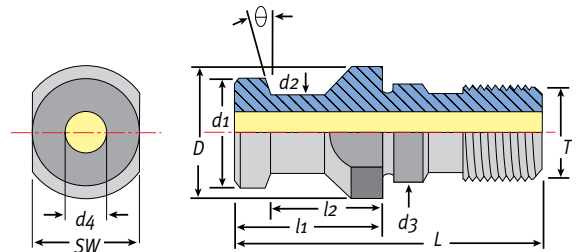

DIN 69871A

DIN 69871 A and B Style Retention Knobs

Dimensions in millimeters.

Part No.	Description	θ	D	d1	d2	d3	d4	L	I1	I2	I3	SW	T
49001	DAT30-A	15°	17	13	9	13	-	44	24	19	-	14	M12
49003	DAT40-A	15°	23	19	14	17	7	54	26	20	-	19	M16
49005	DAT50-A	15°	36	28	21	25	11.5	74	34	25	-	30	M24
49011	DAT30-B	15°	17	13	9	13	-	44	24	19	2.3	14	M12
49013	DAT40-B	15°	23	19	14	17	7	54	26	20	3.0	19	M16
49015	DAT50-B	15°	36	28	21	25	11.5	74	34	25	4.5	30	M24

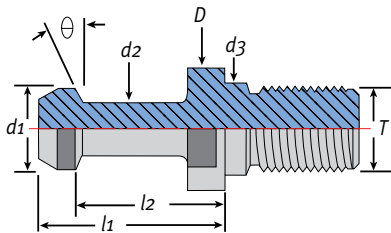

Hard-To-Find- Retention Knobs

We can get the Retention Knobs you need. Just fill in your dimensions on the chart below before you call.

Keep your information in this catalog for easy re-orders.

Stud	Machine	d1	d2	I1	I2	θ	T



CAT & BT Alignment Tools, HSK Calibration Tools

Part No.	Description
21000-CAT40-3	CAT 40 Alignment Tool - 3 pcs
21000-CAT50-3	CAT 50 Alignment Tool - 3 pcs
16000-BT30-3	BT 30 Alignment Tool - 3 pcs.
171.02.002.000	HSK 63F Calibration Tool - 4.975"

Hand Wrenches for Collet Nuts



DNA slotted wrench



ER hex wrench



ER or TG slotted wrench



ER mini wrench



TG hook wrench

Note: Correct torque on the collet nut reduces collet wear and improves safety by properly securing cutting tool in the holder. Use the torque chart on page 72 for tightening collet nuts. Do not overtighten nuts or you may damage the collet and/or toolholder.

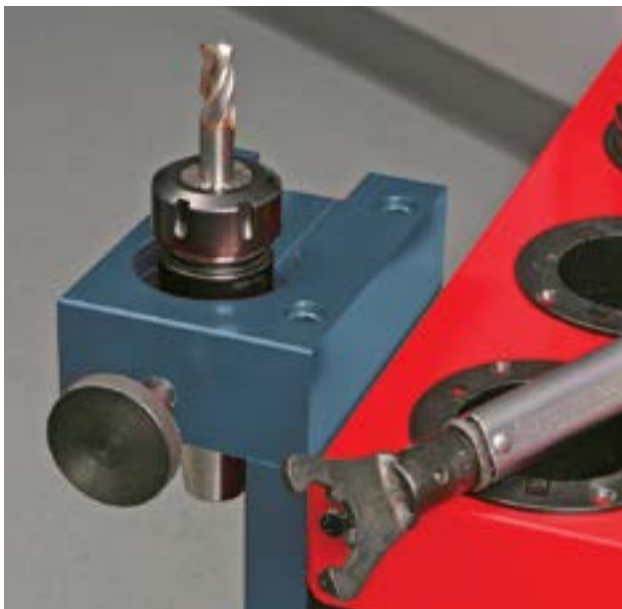

Use a tightening fixture to secure the toolholder. (pg. 206)

DNA Hand Wrenches

Part No.	Description	Nut Type
DNA11W	DNA 11 wrench	DNA-11
DNA16W	DNA 16 wrench	DNA-16
DNA20W	DNA 20 wrench	DNA-20
DNA32W	DNA 32 wrench	DNA-32
894-22	DNA 16 mini nut wrench	DNA-16 Mini

ER Hex Hand Wrenches

Part No.	Description	Nut Type
894-36	TE-Short wrench	TE Short
04608	ER11-A wrench	A (Hex)
04609	ER16-A wrench	A (Hex)
04610	ER20-A wrench	A (Hex)

ER Slotted Hand Wrenches

Part No.	Description	Nut Type
04613	ER16-E wrench	Slotted
04614	ER20-E wrench	Slotted
04615	ER25-E wrench	Slotted
04616	ER32-E wrench	Slotted
04617	ER40-E wrench	Slotted
04618	ER50-E wrench	Slotted

ER Mini Hand Wrenches

Part No.	Description	Nut Type
04620	ER8-M wrench	ER Mini
04621	ER11-M wrench	ER Mini
04622	ER16-M wrench	ER Mini
04623	ER20-M wrench	ER Mini
04624	ER25-M wrench	ER Mini

TG, SYOZ and Drill Chuck Hand Wrenches

Part No.	Description	Nut Type
04018	TG 75 slotted wrench 45–50mm	TG 75
03691	TG 100/SYOZ 25 hook wrench 55–60mm	TG 100
22220	SYOZ 20 wrench	SYOZ 20
82172	Drill Chuck wrench	Chuck

Adjustable Torque Wrenches & Collet Key Adapters



Torque Wrench Features

- Factory calibrated and certified accuracy +/- 3%
- Easy read dial for fast adjustments to torque value
- Improved locking system for a more secure lock



Set adjustable dial to specified torque, and tighten nut until wrench "clicks".

Improved "pull-release" locking system makes locking wrench at correct torque more secure.

Adjustable Torque Wrench

Part No.	Range	Length	Weight	Spigot
50TH	7.5-37.5 ft/lbs	12.5"	1.4 lbs	16mm round NEW
200TH	30-150 ft/lbs	16.5"	1.75 lbs	16mm round
300TH	45-228 ft/lbs	21.5"	2.5 lbs	16mm round



ER Mini Collet Key Adapters

Part No.	Size	Type	Torque
04576	ER11 mini	mini	12 ft/lbs
04577	ER16 mini	mini	20 ft/lbs
04578	ER20 mini	mini	22 ft/lbs
04587	ER25 mini	mini	28 ft/lbs

ER Hex Collet Key Adapters

Part No.	Size	Type	Torque
04581	ER11 hex	hex	12 ft/lbs
04601-16	ER16 hex	hex	42 ft/lbs
04602-20	ER20 hex	hex	59 ft/lbs

TG and SYOZ Collet Key Adapters

Part No.	Size	Type	Torque
04018-TWA	TG 75, 45-50mm	hook	90 ft/lbs
03690-25	TG 100/SYOZ25, 55-60mm	hook	90 ft/lbs
04593	SYOZ-20	hook	40 ft/lbs

ER Slotted Collet Key Adapters

Part No.	Size	Type	Torque
04581	DNA 11	hex	12 ft/lbs
DNA16TWA	DNA 16	slotted	42 ft/lbs
DNA20TWA	DNA 20	slotted	59 ft/lbs
DNA32TWA	DNA 32	slotted	100 ft/lbs
04588-R	ER 32 Enclosed	slotted	100 ft/lbs
04580-16	ER16 slotted	slotted	42 ft/lbs
04580-20	ER20 slotted	slotted	59 ft/lbs
04603-25	ER25 slotted	slotted	77 ft/lbs
04604-32	ER32 slotted	slotted	100 ft/lbs
04605-40	ER40 slotted	slotted	130 ft/lbs

Retention Knob Sockets Square Drive



Part No.	Size	Flats	Drive	Torque
PSS-30BT	BT30	0.535"	3/8"	36 ft/lbs
PSS-30ISO	ISO 30	0.535"	3/8"	36 ft/lbs
PSS-40	All 40 taper	0.750"	3/8"	76 ft/lbs
PSC-50	CAT50, BT50	1.187"	1/2"	100 ft/lbs

Fixed Head Square Drives

Part No.	Description	Drive
29828	3/8" square drive	3/8"
29827	1/2" square drive	1/2"



Tightening Fixtures For CAT, BT, HSK, & ISO Spindles

Roller Bearing Tightening Fixture

- For CAT, BT, HSK, ISO spindles
- Roller bearing design for the fastest tool changes possible!



Auto-locking roller bearing design makes tool changes faster and eliminates slippage.

NTS Side Mount Tightening Fixtures

- For CAT, BT, HSK, ISO spindles
- Change knobs from bottom
- Bolts right to workbench



HSK style shown

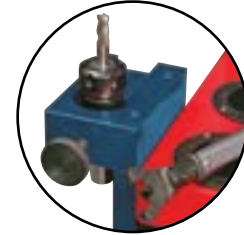

NOTE: a large set-screw engages the drive slot in BT and CAT holders.

Part No.	Description
17385B	roller bearing fixture for ISO30, SK30, HSK50
17386B	roller bearing fixture for BT30
17386B-35	roller bearing fixture for BT35
17584B	roller bearing fixture for HSK32
17586B	roller bearing fixture for HSK40
17786B	roller bearing fixture for HSK100
17846B	CAT40 BT40, ISO40, HSK63A, HSK63E, HSK63F
17387B	Clamping Device - HSK85 Weining

CAT40 and BT30 NTS Fixtures

Part No.	Description
NTS-40-TAPER	NTS Fixture for any CAT40 or BT40 taper
NTS-BT30-38	NTS Fixture for BT30 taper - 38mm flats
NTS-BT30-41	NTS Fixture for BT30 taper - 41mm flats
NTS-BT30-SLOT	NTS Fixture for BT30 for drive slots

Top or Side Mount Fixtures

- For CAT, BT, HSK, spindles
- Change knobs from bottom
- Bolts right to workbench



BT, CAT style shown

Part No.	Description
17883	top or side-mount fixture for BT30, CAT 30
07884	top or side-mount fixture for BT40, CAT40
07885	top or side-mount fixture for BT50, CAT50
17893	top or side-mount fixture for HSK63A, 63B, 63D

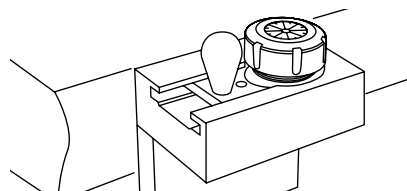

NOTE: a sliding collar engages the wrench flats on HSK and toolholders without drive slots.

HSK63 NTS Fixtures

Part No.	Description
NTS-HSK63A	HSK63A - no flats
NTS-HSK63F-36	HSK63F - 36mm flats
NTS-HSK63F-38	HSK63F - 38mm flats
NTS-HSK63F-41	HSK63F - 41mm flats
NTS-HSK63F-46	HSK63F - 46mm flats

Benchtop Mount Fixture for CAT & BT

Part No.	Description
07852	BT30
07854	BT40
07856	BT50
07870	CAT40
07872	CAT50



ISO NTS Fixtures

Part No.	Description
NTS-ISO20-17	ISO 20 - 17mm flats
NTS-ISO20-22	ISO 20 - 22mm flats
NTS-ISO25-27	ISO 25 - 27mm flats
NTS-ISO30-36	ISO 30 - 36mm flats
NTS-ISO30-38	ISO 30 - 38mm flats
NTS-ISO30-47	ISO 30 - 47mm flats

Spindle Wipers – Analog & Touch Lamp Preset Gauges



Real lambskin provides the best cleaning. Use with any type of machine with a taper of 7/24 CAT, BT or DIN 69871.

Spindle Wipers

- For CAT, BT, ISO, HSK spindles
- Keep spindle and tapers clean

Part No.	Taper
17706	30
17707	40
17708	50
38036	HSK63A
38032	HSK63F

Magnetic V-Blocks & V-Block Sets

- See page XX
- Fast and powerful workholding



Analog Axial Preset Gauge Features

- Accuracy 0.0002"
- Easy to measure tool depth
- Height 50mm

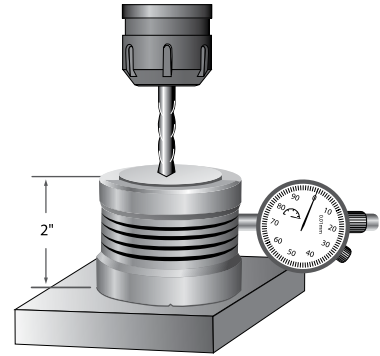
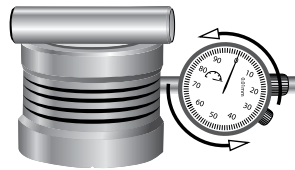

Analog Axial Preset Gauge

Part No.	Description
17906-2	ZSI-50 preset gauge
17906-04	replacement dial

1. Use the gauge pin included to press down on the spring-loaded center piece as illustrated. Please be sure the gauge pin is placed on the shiny surface.
2. Turn the indicator to read "0", then remove the gauge pin.

3. Put the unit on the workpiece and carefully jog the tool down to make contact with the gauge face. When the gauge reads "0" the tool is 2" above the workpiece.



Instructions

1. Check height of unit with a gauge block and dial indicator. Turn allen screw on the side of the unit if adjustment is needed.
2. Do not use calipers for presetting unit, only use gauge block.
3. Move the cutting tool tip towards the sensor button until the unit lights up, then reverse direction until the light goes off.
4. When presetting diameter, rotate tool slowly for higher precision.

Touch Lamp Axial Preset Gauge Features

- Accuracy .0002"
- 360° red lamp lights up when touched
- Height 2" (50mm)
- Magnetic base (use vertically or horizontally)

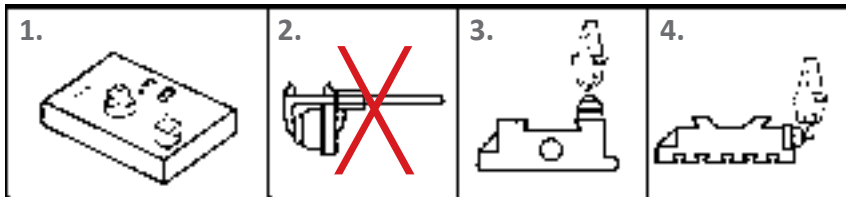
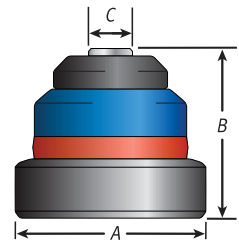

Touch Lamp Axial Preset Gauge

Part No.	Description	A	B	C
07905-2	ZOP-50 Gauge	56mm	50mm or 2"	13.5mm



Coolant-Thru Pre-Set Screws

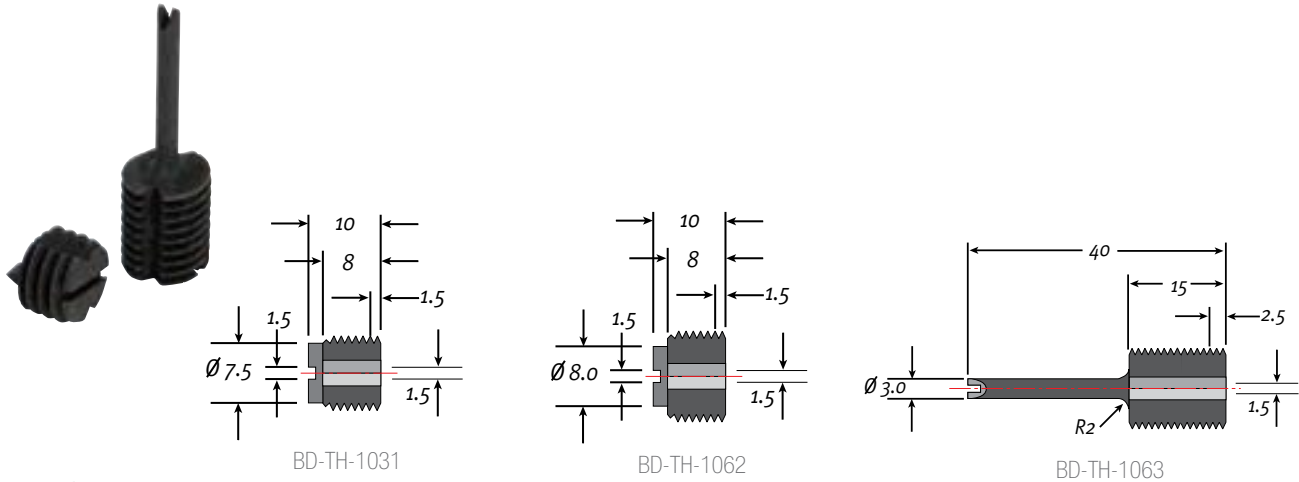

Coolant Set Screws

Part No.	Description
BD-TH-1031	For M10 x 1.5 straight shank chuck with coolant – for small diameter tools
BD-TH-1062	For M12 x 1.75 straight shank chuck w/ coolant – for small diameter tools
BD-TH-1063	Long stop for M12 x 1.75 straight shank chuck w/coolant – for small diameter tools

Coolant Set Screws

Part No.	Description	M	L	d
16080C-20	Coolant Set Screw	M5 x 0.8P	20mm	2.5
16082C-20	Coolant Set Screw	M8 x 1.25P	20mm	4
16083C-20	Coolant Set Screw	M10 x 1.5P	20mm	4
16085C-20	Coolant Set Screw	M12 x 1.75P	20mm	4
16089C-20	Coolant Set Screw	M16 x 02.0P	20mm	5
16091C-20	Coolant Set Screw	M20 x 2.0P	20mm	5

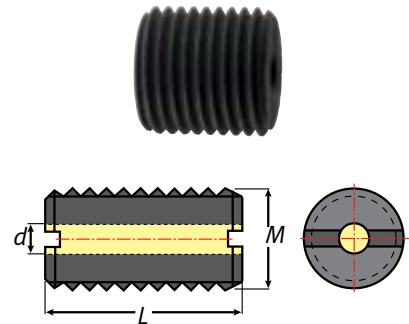

Solid Pre-set Screws for ER and TG Collet Chucks

Part No.	Description	Figure	Collet Series
16081	M 6 x 1.0 P - 15	1	ER11
16083	M 10 x 1.5 P - 15	1	ER16
16085	M 12 x 1.75 P - 15	1	ER20
16087	M 12 x 1.75 P - 25 (extended)	2	ER20
16088	M 8 x 1.25 P - 16	1	-
16089	M 16 x 2.0 P - 15	1	ER25 & 32, TG 75
16096	M 16 x 2.0 P - 50	-	-
16091	M 20 x 2.0 P - 15	1	ER40
16094	M 20 x 2.0 P - 50	-	-
16092	M20 x 2.0P - 100	-	-
16093	M 24 x 2.0 P - 15	1	ER50 & TG 100

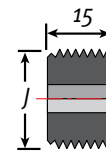

Figure 1

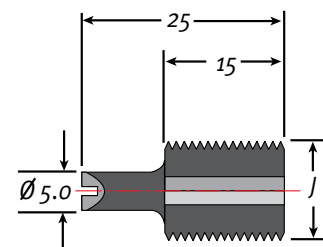

Figure 2

MagVISE Workholding Systems

Magnetic Chucks



We Provide Turn-Key Magnetic Workholding Solutions

Contact us for solutions to your workholding bottlenecks.

MagVISE
WORKHOLDING

Modular Chucks



Horizontal Chucks



Indexing Chucks

Round Chucks

For vertical turning, grinding and 5-axis tables

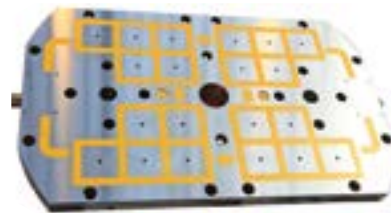

Injection
Mold
Clamping

Magnetic Vises



Surface Grinding Chucks



Built for Speed.



View Magnetic Workholding videos at:
<http://ow.ly/tL1Yo>

All Techniks products are backed by our 100% satisfaction guarantee!

Customized Magnetic Workholding Solutions

Engineered Turn-Key Solutions

Since 2001, Techniks has designed, built and installed the best magnetic workholding solutions in the industry. We offer a wide range of standard magnetic chucks and vises. You also benefit from the expertise of our engineers, capable of creating solutions for all types of unique applications and parts.

Our engineers can duplicate your application using our in-house CNC Tech Center in order to provide turn-key solutions that easily integrate to your system and maximize production.



Large plate EEPM customized to fit your system

Rail production

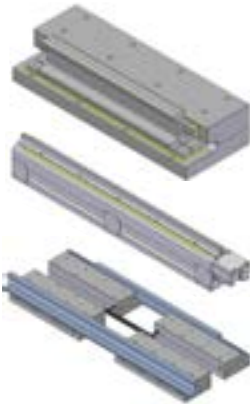

Complex workpieces



Automated pallet systems

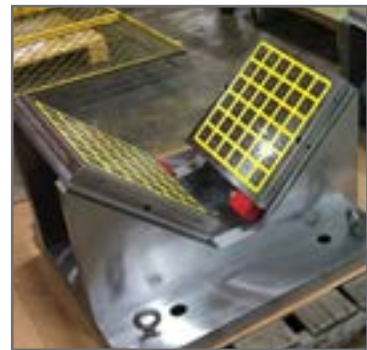
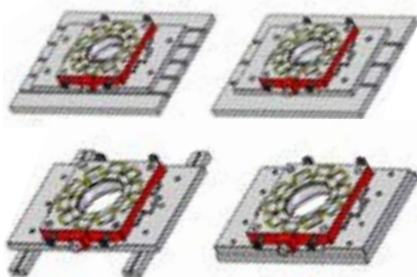

MagVISE EEPM Magnetic Workholding Chucks



EEPm chucks come with controller, a standard remote, and a touch-screen remote.

MagVISE
WORKHOLDING

Features:

- Up to 86,625 lbs holding power
- Turn chuck ON/OFF in only a few seconds – chuck will not lose magnetism if a power loss occurs
- Induction block and subplates provide additional setup options for small parts or wrapped stock

Advantages:

- Machine freely on 5-sides & top so you can cut the full part profile in only one operation
- Reduce setup & change-over time by 50% or more!
- Very uniform holding = No workpiece deformation

Compared to traditional fixturing methods, magnetic workholding frees up all five sides of your workpiece so you can machine an entire profile in one set-up. Magnetic workholding greatly reduces set up and part change-over time, giving your spindle more time to make chips.

Thick or thin, large or small – just about any ferrous material can be held and machined magnetically. Bigger parts are easier to hold because there is more metal for the magnetism to be attracted to.

For smaller parts, using work stops and nesting the part are options that work well. Magnetic workholding is used for just about any type of drilling, milling, and boring operation you can think of, on horizontal or vertical CNC machines.

Application Examples

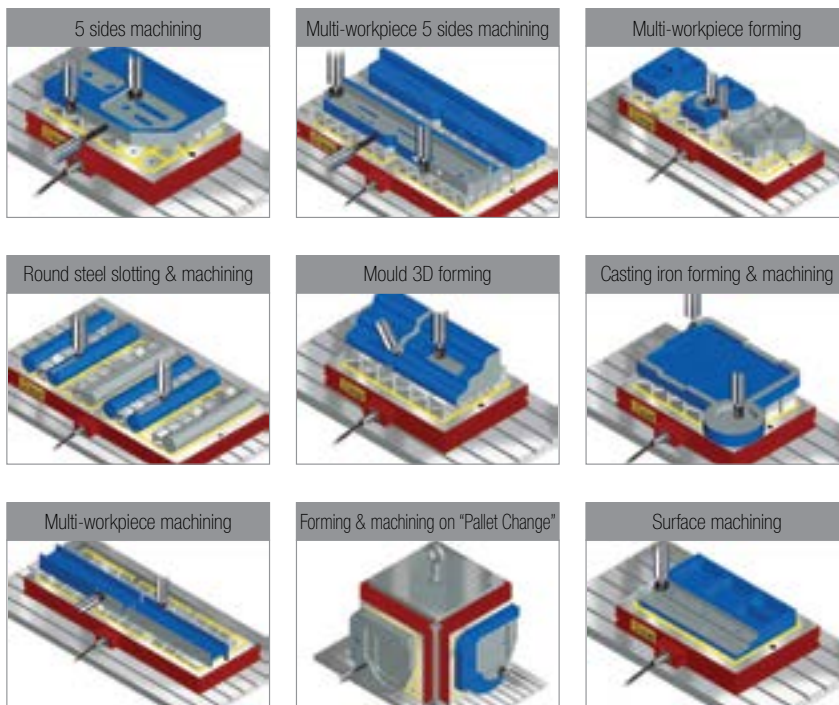

Holding Power Example

EEPm 3040W chuck (left) has 20 poles, and produces 16,500 ft/lbs of holding power.

How It Works

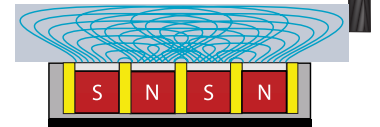

In the ON state, alnico and rare-earth magnets alternate poles, creating a powerful magnetic attraction. Holding power varies with type of material being held, surface finish, and part thickness.

Minimum recommended part size is 5" x 5" x 3/8" thick, so a minimum of 4 magnetic poles are covered by the part. Workstops, pins or part nesting techniques ensure the ability to hold small, thin parts without movement.

Induction Blocks & Subplates

We recommend using induction blocks or subplates at all times to preserve the precision ground finish and prevent damage to the face of the magnetic chuck.



Scan the QR code to view or View our Workholding videos at: <http://ow.ly/tL1Yo>

NEW

MagVISE For Large Workpieces



70MM Pole Features:

- Up to 98,767 lbs. holding power
- Reduce setup time by 50%
- Machine freely on 5-sides

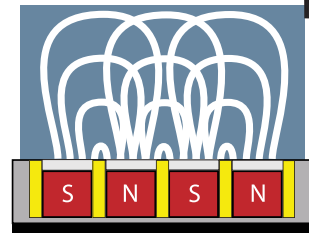

Our 70MM pole chucks provide the increased holding power needed for large workpieces, thick plates, blocks and molds. Great choice for drilling, milling, and boring operations on vertical or horizontal mills. They easily integrate with pallet changing and tombstone systems.

We stand behind our workholding solutions with full factory support to guarantee your satisfaction. Custom solutions built to your specifications are fully tested and are provided at no extra cost.

70mm pole chucks provide the most powerful flux lines with the deepest extension into the workpiece. Most effective for over-sized workpieces.

$$S = 1.2" \quad G = 0.78"$$

$$S1 = 1" \quad M = 1.2"$$

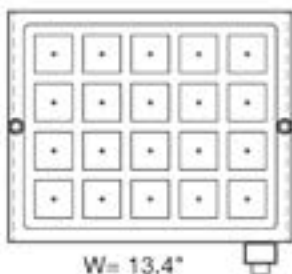

Figure 1

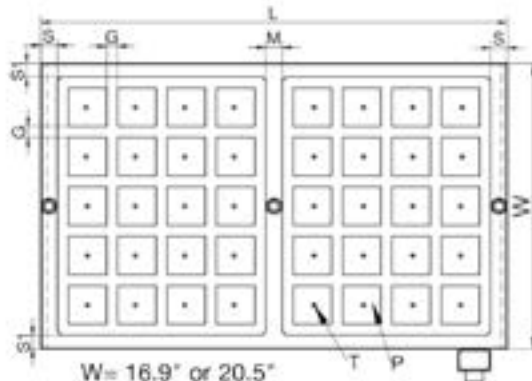

Figure 2

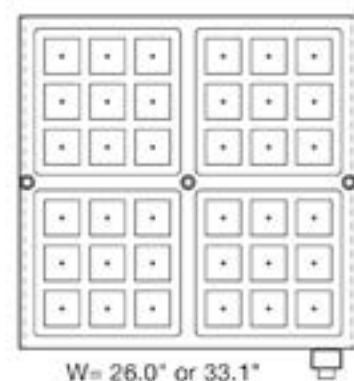
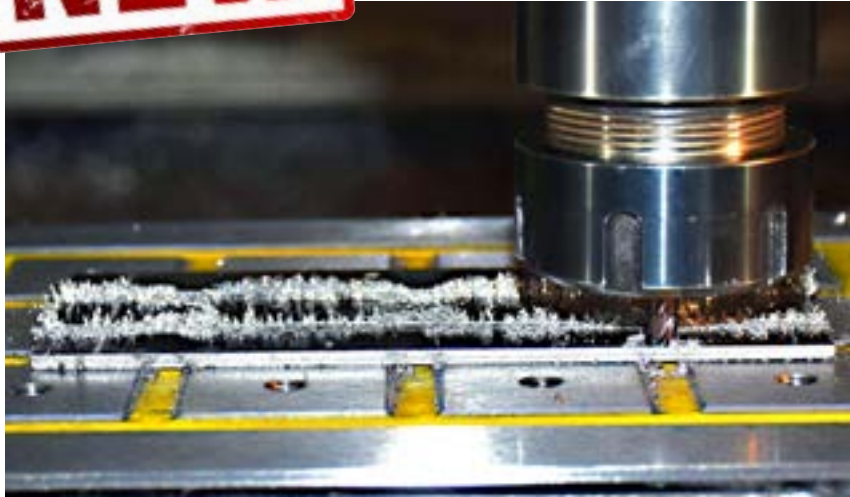

Figure 3

Model	Fig	L x W x H	Poles	Holding Pwr.	Subplate	Single Phase	Control	Weight
EEPM-3060D-220	1	26.4"x13.4"x2.8"	18	27,778 lbs.	EEPM-3060DISP	220-480V	EEPM-C1	278 lbs.
EEPM-4050D-220	2	20.9"x16.9"x2.8"	20	30,864 lbs.	EEPM-4050DISP	220-480V	EEPM-C1	278 lbs.
EEPM-4060D-220	2	26.4"x16.9"x2.8"	24	37,037 lbs.	EEPM-4060DISP	220-480V	EEPM-C1	350 lbs.
EEPM-4080D-220	2	33.5"x16.9"x2.8"	32	49,383 lbs.	EEPM-4080DISP	220-480V	EEPM-C2	445 lbs.
EEPM-5060D-220	2	26.4"x20.5"x2.8"	30	46,297 lbs.	EEPM-5060DISP	220-480V	EEPM-C2	425 lbs.
EEPM-5080D-220	2	33.5"x20.5"x2.8"	40	61,729 lbs.	EEPM-5080DISP	220-480V	EEPM-C2	538 lbs.
EEPM-6060D-220	3	26.4"x26.0"x2.8"	36	55,556 lbs.	EEPM-6060DISP	220-480V	EEPM-C2	540 lbs.
EEPM-6080D-220	3	33.5"x26.0"x2.8"	48	74,075 lbs.	EEPM-6080DISP	220-480V	EEPM-C2	683 lbs.
EEPM-8080D-220	3	33.5"x33.1"x2.8"	64	98,767 lbs.	EEPM-8080DISP	220-480V	EEPM-C4	870 lbs.

NEW

MagVISE For Small or Thin Workpieces



35MM Pole Features:

- Up to 34,524 lbs. holding power at 100% contact
- Reduce operations designed for thin material
- Reduce setup time by 50%

Our 35MM pole chucks are built specifically for the machining of thin workpieces. They are a great choice for drilling, milling, and boring operations on either vertical or horizontal mills. They easily integrate with pallet changing and tombstone systems.

We stand behind our workholding solutions with full factory support to guarantee your satisfaction. Custom solutions built to your specifications are fully tested and are provided at no extra cost.

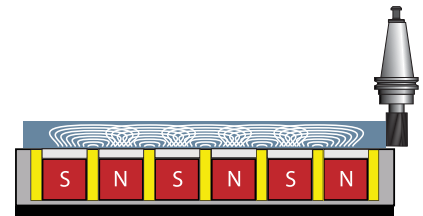

35mm pole chucks feature flux lines concentrated closer to the surface, providing more magnetic coverage of thin material.

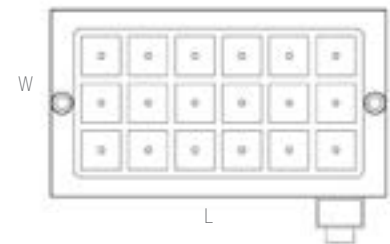

Model	L x W x H	Poles	Holding Power	Subplate	Power (single phase)	Controller	Weight
EEPM-1530A-220	12.6" x 7.3" x 1.9"	18	5,754 lbs.	EEPM-1530ISPA	220-480V	EEPM-C1	51 lbs.
EEPM-2540A-220	17.3" x 8.9" x 1.9"	32	10,229 lbs.	EEPM-2540ISPA	220-480V	EEPM-C1	86 lbs.
EEPM-2560A-220	24.0" x 8.9" x 1.9"	48	15,344 lbs.	EEPM-2560ISPA	220-480V	EEPM-C2	119 lbs.
EEPM-3030A-220	12.6" x 12.2" x 1.9"	36	11,508 lbs.	EEPM-3030ISPA	220-480V	EEPM-C1	86 lbs.
EEPM-3040A-220	17.3" x 12.2" x 1.9"	48	15,344 lbs.	EEPM-3040ISPA	220-480V	EEPM-C2	117 lbs.
EEPM-3060A-220	24.0" x 12.2" x 1.9"	72	23,016 lbs.	EEPM-3060ISPA	220-480V	EEPM-C2	163 lbs.
EEPM-4040A-220	17.3" x 17.1" x 1.9"	72	23,016 lbs.	EEPM-4040ISPA	220-480V	EEPM-C2	165 lbs.
EEPM-4050A-220	20.7" x 17.1" x 1.9"	90	28,770 lbs.	EEPM-4050ISPA	220-480V	EEPM-C4	198 lbs.
EEPM-4060A-220	24.0" x 17.1" x 1.9"	108	34,524 lbs.	EEPM-4060ISPA	220-480V	EEPM-C4	229 lbs.



MagVISE EEPM Ordering Information

Ordering EEPM Workholding Chucks and Subplates

- Select a chuck larger than your part for maximum holding power
- Subplates are sized to match the chuck but are 1" thick – See table below
- Control requires dedicated, 480v, single phase, 30A power



induction block

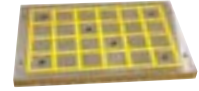

subplate

Use induction blocks or subplates at all times to preserve the precision ground finish and prevent damage to the face of the magnetic chuck.

$$S = 1.2" \quad S1 = 1" \quad G = 0.4 \quad M = 1.2"$$

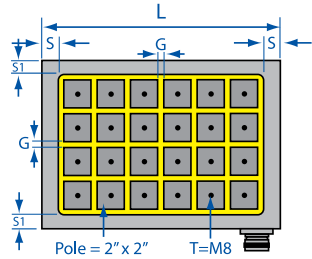

Fig. 1

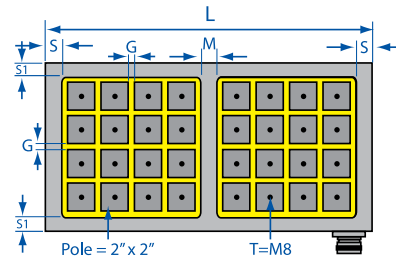

Fig. 2

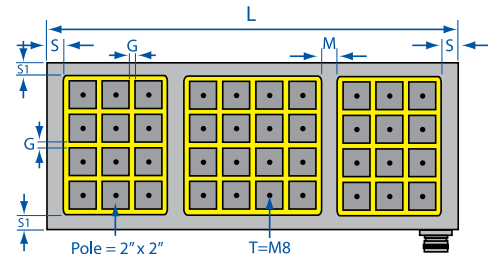

Fig. 3

MagVISE
WORKHOLDING

Model	Fig	L x W x H	Poles	Holding Power	Chuck Weight	Subplate	Controller
EEPM-2540W-220	1	16.9" x 9.4" x 2.8"	18	12,375 lbs.	110 lbs.	EEPM-2540ISP	EEPM-C1
EEPM-2560W-220	2	23.2" x 9.4" x 2.8"	24	16,500 lbs.	152 lbs.	EEPM-2560ISP	EEPM-C1
EEPM-2580W-220	3	31.9" x 9.4" x 2.8"	33	22,687 lbs.	202 lbs.	EEPM-2580ISP	EEPM-C1
EEPM-2590W-220	3	34.3" x 9.4" x 2.8"	36	24,750 lbs.	216 lbs.	EEPM-2590ISP	EEPM-C2
EEPM-25100W-220	3	39.0" x 9.4" x 2.8"	42	28,875 lbs.	244 lbs.	EEPM-25100ISP	EEPM-C2
EEPM-3030W-220	1	12.2" x 11.8" x 2.8"	16	11,000 lbs.	97 lbs.	EEPM-3030ISP	EEPM-C1
EEPM-3040W-220	1	16.9" x 11.8" x 2.8"	24	16,500 lbs.	134 lbs.	EEPM-3040ISP	EEPM-C1
EEPM-3060W-220	2	23.2" x 11.8" x 2.8"	32	22,000 lbs.	180 lbs.	EEPM-3060ISP	EEPM-C1
EEPM-3080W-220	3	31.9" x 11.8" x 2.8"	44	30,250 lbs.	255 lbs.	EEPM-3080ISP	EEPM-C2
EEPM-3090W-220	3	34.3" x 11.8" x 2.8"	48	33,000 lbs.	271 lbs.	EEPM-3090ISP	EEPM-C2
EEPM-30100W-220	3	39.0" x 11.8" x 2.8"	56	38,500 lbs.	304 lbs.	EEPM-30100ISP	EEPM-C2
EEPM-4040W-220	1	16.9" x 16.5" x 2.8"	36	24,750 lbs.	185 lbs.	EEPM-4040ISP	EEPM-C1
EEPM-4050W-220	1	18.9" x 16.9" x 2.8"	42	28,875 lbs.	209 lbs.	EEPM-4050ISP	EEPM-C2
EEPM-4060W-220	2	23.2" x 16.5" x 2.8"	48	33,000 lbs.	255 lbs.	EEPM-4060ISP	EEPM-C2
EEPM-4080W-220	3	31.9" x 16.5" x 2.8"	66	45,375 lbs.	350 lbs.	EEPM-4080ISP	EEPM-C2
EEPM-4090W-220	3	34.3" x 16.5" x 2.8"	72	49,500 lbs.	372 lbs.	EEPM-4090ISP	EEPM-C2
EEPM-40100W-220	3	39.0" x 16.5" x 2.8"	84	57,750 lbs.	425 lbs.	EEPM-40100ISP	EEPM-C4
EEPM-5060W-220	2	23.2" x 18.9" x 2.8"	56	38,500 lbs.	284 lbs.	EEPM-5060ISP	EEPM-C2
EEPM-5080W-220	3	31.9" x 18.9" x 2.8"	77	52,937 lbs.	407 lbs.	EEPM-5080ISP	EEPM-C4
EEPM-5090W-220	3	34.3" x 18.9" x 2.8"	84	57,750 lbs.	431 lbs.	EEPM-5090ISP	EEPM-C4
EEPM-50100W -220	3	39.0" x 18.9" x 2.8"	98	67,375 lbs.	482 lbs.	EEPM-50100ISP	EEPM-C4
EEPM-6060W-220	2	23.2" x 23.6" x 2.8"	72	49,500 lbs.	363 lbs.	EEPM-6060ISP	EEPM-C2
EEPM-6080W-220	3	31.9" x 23.6" x 2.8"	99	68,062 lbs.	473 lbs.	EEPM-6080ISP	EEPM-C4
EEPM-6090W-220	3	34.3" x 23.6" x 2.8"	108	74,250 lbs.	528 lbs.	EEPM-6090ISP	EEPM-C4
EEPM-60100W-220	3	39.0" x 23.6" x 2.8"	126	86,625 lbs.	603 lbs.	EEPM-60100ISP	EEPM-C4
EEPM-8080W-220	3	31.9" x 29.7" x 2.8"	121	83,187 lbs.	596 lbs.	EEPM-8080ISP	EEPM-C4

MagVISE Induction Blocks & Subplates For EEPM

Induction Blocks & Subplates

We recommend using induction blocks or subplates at all times to preserve the precision ground finish and prevent damage to the face of the magnetic chuck. Order subplates from the table on page 242.

Individual Induction Blocks

Use induction blocks to raise the workpiece above the surface of the magnet and permit machining 5 sides and thru-hole drilling. Individual induction blocks provide maximum flexibility for creating custom setups for holding difficult workpieces and warped stock.



Example: machined solid blocks to hold round stock.

EEPM-PS40 workstop



Round Fixed & Spring-loaded Blocks



Part No.	Description	L	W	H
EEPM-SP	spring loaded (2 piece set, 8mm screw)	1.89"	1.89"	1.41"
EEPM-SPF	solid, machinable (8mm screw)	1.97"	1.97"	1.23"

Connected Induction Blocks

Makes setups faster and easier when large numbers of induction blocks are required. Choose from 2, 3, 4, or 6 pole configurations.



Part No.	Desc.	L	W	H
EEPM-IB225	2-pole block	4"	1.97"	.98"
EEPM-IB325	3-pole block	6"	1.97"	.98"
EEPM-IB425	4-pole block	8"	1.97"	.98"
EEPM-IB625	6-pole block	12"	1.97"	.98"

Angled Induction Blocks & Workstop

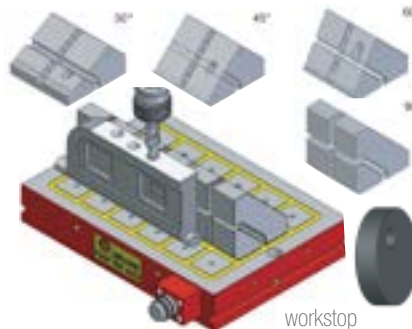

Part No.	Desc.
EEPM-IBT30	30° angle, 4-pole induction block
EEPM-IBT45	45° angle, 4-pole induction block
EEPM-IBT60	60° angle, 4-pole induction block
EEPM-IBT90	90° angle, 4-pole induction block
EEPM-PS40	round workstop (replacement)

Setup Notes

Always make sure you read, understand and follow all the Owner's Manual instructions and CAUTIONS that come with your EEPM Magnetic Chuck before setting it up and using it.

After installing your induction blocks we recommend cleanup milling the surface of your induction blocks before loading your work piece to insure that the surface height is uniform and parallel to the spindle. Subplates are precision ground and do not require cleanup milling.

Please note that the spring loaded induction blocks are NOT machineable, but the solid blocks are able to be drilled and machined as required.

Holding Warped Material

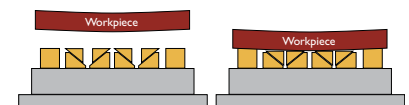

Use EEPM-SPF induction blocks on the corners and EEPM-SP spring loaded blocks everywhere else so the induction blocks adjust to match the warped stock.

Part Nesting Techniques



For machining small, thin, or irregular parts that do not have much metal to attract the magnet, you can create a shallow nest, or pocket in a subplate or induction blocks to secure the part and prevent lateral movement. For part nests that you will use over-and-over again on repeat jobs use subplates to save setup time.

MagVISE EEPM-C Modular Workholding Chucks



Features:

- Modular connectivity capable of conforming multiple chucks to your unique part and set up
- Operate as many as 16 chucks with 1 control
- 8,250 lbs. holding power (each chuck)*

Advantages:

- Easy to setup and adjust for large or irregular parts
- Reduced investment versus larger EEPM chucks
- Easy to move and setup from machine to machine

EEP-C chucks provide almost unlimited flexibility to hold workpieces of varying sizes. Use toe-clamps or bolts to position EEPM-C magnets anywhere on your machine bed or pallet to fit your workpiece.

*Holding power varies with material being held, surface finish, and part thickness.



Use for fast setups on plate stock



Configure multiple chucks to a variety of setups



Large tooth sprocket being machined



Modular setups adjust easily to part

MagVISE
WORKHOLDING

MagVISE EEPM-C Ordering Information

Ordering EEPM-C Modular Chucks

- Select the number of chucks required
- Select the control required to operate the number of chucks needed
- Select the number and length of connection cables required

We recommend using induction blocks at all times to preserve the surface finish of your magnetic chuck, and prevent damage to the face of the magnetic chuck.

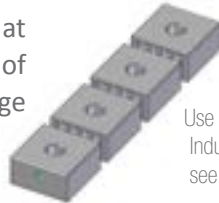

Use with EEPM-IB425 Induction Blocks see page 243

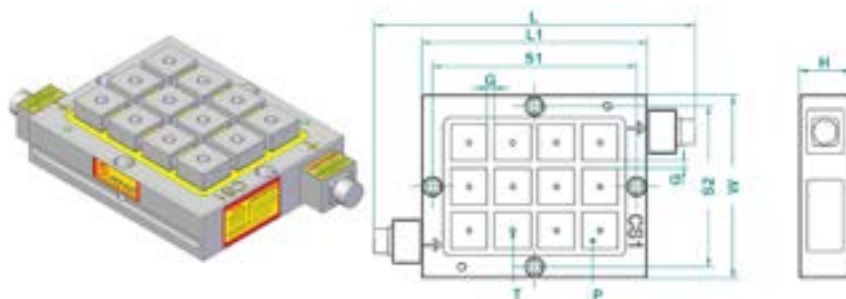

Chuck	L	W	H	L1	S1	S2	Poles	Power*
EEPM-2530C	16.75"	9.84"	X	12.25"	11.0"	8.66"	12	8,250 lbs.

*Holding power varies with type of material being held, surface finish, and part thickness.

Control requires a dedicated 480V single phase, 30A power supply

C4 control features 4 channels to control up to 16 chucks. Control each channel independently.



Control	Description	L x W x H	Channels	Qty. Chucks
EEPM-C4C	Control for 1-16 EEPM-C magnetic chucks	10.6" x 7" x 5"	4	1-16



Connection Cables	Length
EEPM-CC03	11.8"
EEPM-CC05	19.6"
EEPM-CC10	39.37"
EEPM-CC15	59"



Installation Example



Up to 16 chucks can be operated from 1 control.



Position the chucks on the machine bed.



Lock them in position using bolts provided.



Connect the control cables to chucks and control



Position workpiece and start machining.

MagVISE EEPM-V For Horizontal Machining

Features:

- Up to 68,640 lbs. holding power*
- Choose from 2 or 4 sided chucks
- 36, 42, or 100 pole chucks, 16.9" to 29.9"

Advantages:

- Reduce setup & change-over time by 50% or more!
- Machine freely on all 5-sides to reduce operations
- Very uniform holding = No workpiece deformation

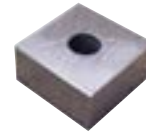

Induction Blocks
see page 243.

Induction Blocks & Subplates

We recommend using induction blocks or subplates at all times to preserve the precision ground finish and prevent damage to the face of the magnetic chuck. For more information see page 243.

*4 sizes available

For workholding of ferrous materials only.
See page 247 for holding power ratings.



Mold making application



2-sided EEPM on palletized system



Hole-making applications are no problem



Complex part shapes - 5 sides machining

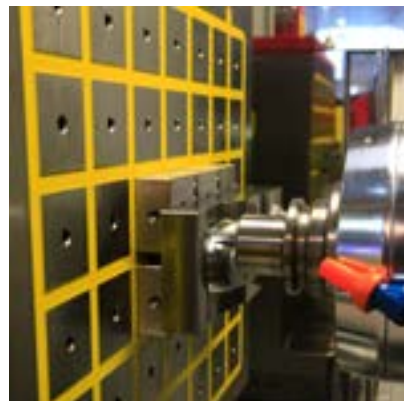

Finish pass using small tools



Palletized horizontal workholding chuck

MagVISE
WORKHOLDING

MagVISE EEPM-V Ordering Information

Ordering EEPM-V Chucks

- Select the number of faces and chucks required
- Control is included with chuck
- Order induction blocks from page 243

We Manufacture Custom Tombstones

- Built to your specifications.
Call us to discuss your needs.
- (800) 597-3921 or local (317) 803-8000



EEPM chucks includes controller and remote.
Control requires a dedicated 480V single phase, 30A power supply

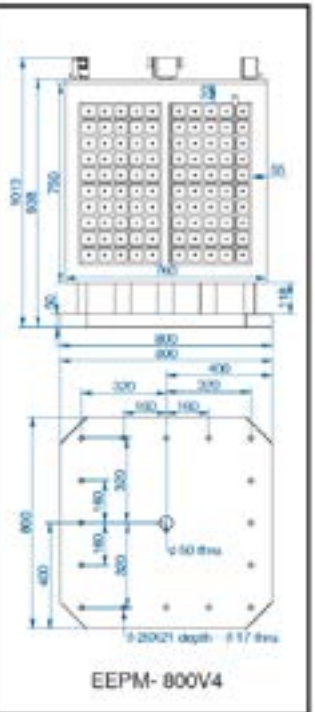
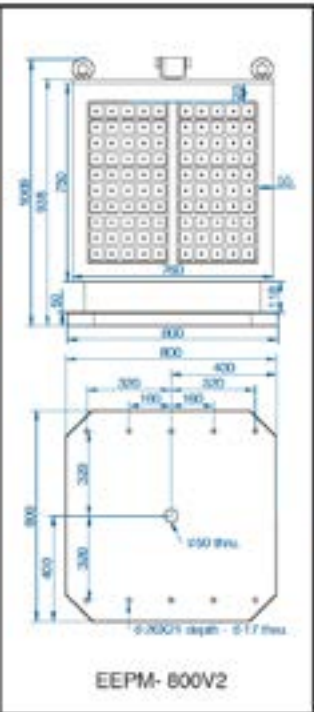
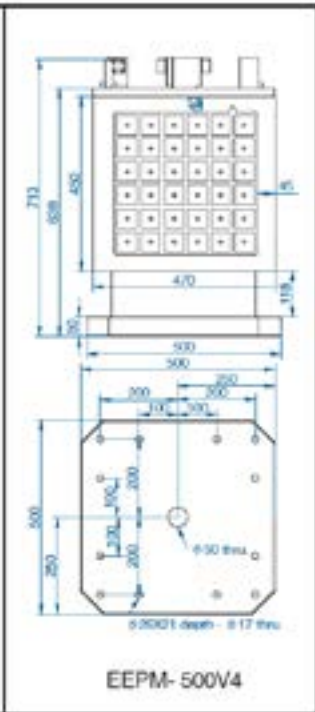
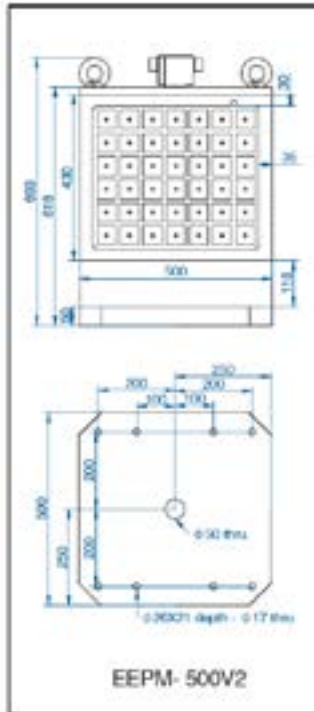

Model	Face (L x W)	No. Faces	No. Poles	Holding Power / Face	Chuck Wt.	Controller
EEPM-500V2	16.9" x 19.68"	2	42	28,820 lbs.	1,058 lbs.	EEPM-C2
EEPM-500V4	17.7" x 18.5"	4	36	24,640 lbs.	1,124 lbs.	EEPM-C2
EEPM-800V2	29.5" x 29.9"	2	100	68,640 lbs.	1,675 lbs.	EEPM-C2
EEPM-800V4	29.5" x 29.9"	4	100	68,640 lbs.	1,786 lbs.	EEPM-C2



MagVISE EEPM-CIR for Vertical Turning & 5-Axis



Advantages:

- Reduce setup & change-over time by 50% or more!
- Machine freely on all 4-sides & top so you can cut the full part profile in only 1 operation
- Very uniform holding = No workpiece deformation

EEPM-CIR chucks are a powerful and fast workholding solution optimized for horizontal or vertical turning centers and 5-axis machining. Using magnetic workholding you can clamp/un-clamp the part in only seconds. Reduce setup down-time to increase machine up-time. Control is included with chuck.

For workholding of ferrous materials only.
9 sizes to choose from. Custom sizes available. includes controller and remote

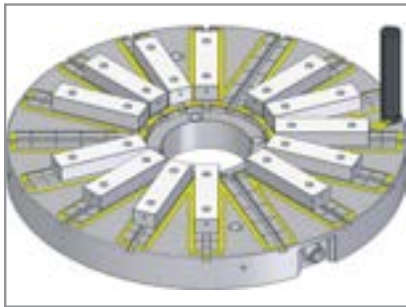

Machine induction blocks for easy part positioning

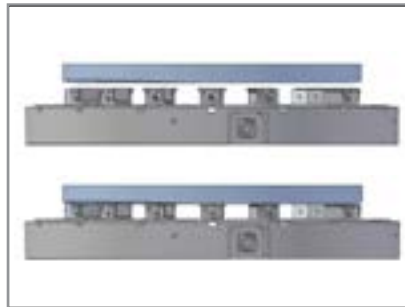

Use with EEPM-SP blocks to hold warped stock

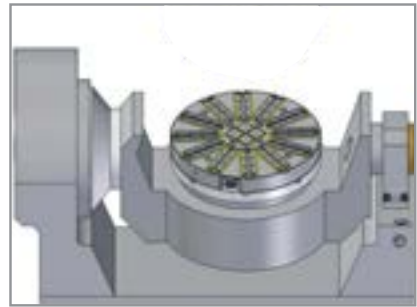

Speed up setups for 5-axis tables



3, 4, and 5-axis applications



Even workholding - no part distortion

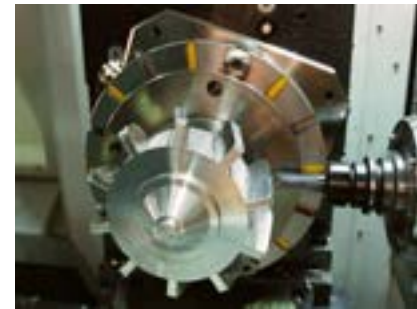

Off-axis rotation on horizontal mill

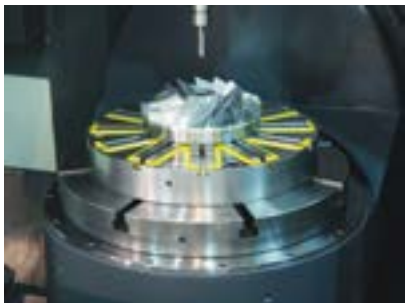

Holds very small or very large parts



Custom chucks available to suit your machine

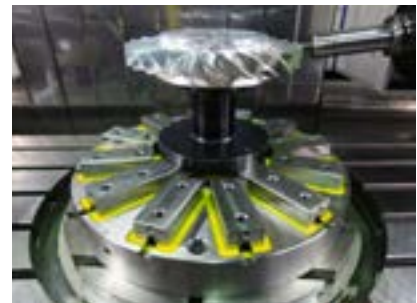

Hold complex parts without complicated setups!

MagVISE
WORKHOLDING

MagVISE EEPM-CIR Ordering Information

Select the Chucks From Tables Below

- We build custom chucks for your specific needs. Call us to discuss.
- (800) 597-3921 or local (317) 803-8000

EEPM chucks includes controller and remote
Control requires a dedicated 480V single phase,
30A power supply

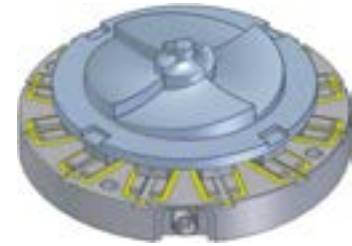

step and slope milling for an impeller

Induction Blocks & T-Slot Sliding Blocks for EEPM CIR Chucks



Use induction blocks to preserve the precision ground finish and prevent damage to the face of the chuck. Induction blocks to raise the workpiece above the surface of the magnet and permit machining 5 sides and thru-hole drilling.

Use T-Slot Sliding Blocks as adjustable workstops for part alignment. See pg. 219 for more induction block options and ideas.

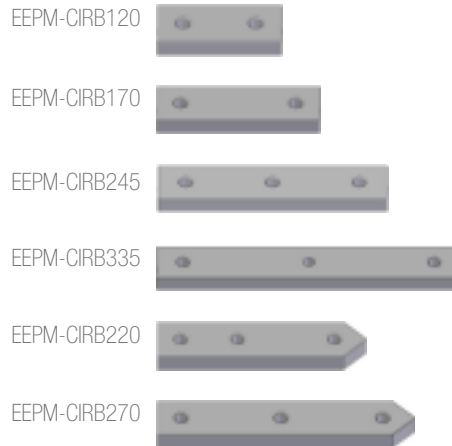

circular chuck setup for gear cutting



pocket milling and face milling



5-axis turbine blade machining

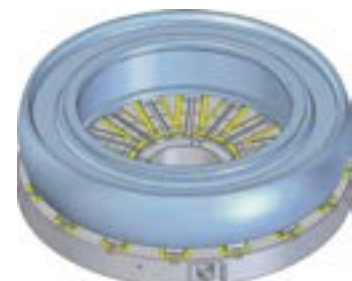

round part turning O.D. and I.D.

Part No.	Description	L	W	H
EEPM-SP	spring loaded (2 piece set, 8mm screw)	1.89"	1.89"	1.41"
EEPM-SPF	solid, machinable (8mm screw)	1.97"	1.97"	1.23"
EEPM-20T	sliding T-slot for use with EEPM-SPF	4.72"	1.97"	.78"
EEPM-30T	sliding T-slot for use with EEPM-SP blocks	4.72"	1.97"	1.18"
EEPM-CIRB120	induction block for CIR500 chuck	4.72"	1.97"	.78"
EEPM-CIRB170	induction block for CIR600 chuck	6.69"	1.97"	.78"
EEPM-CIRB245	induction block for CIR800 chuck	9.64"	1.97"	.78"
EEPM-CIRB335	induction block for CIR1000 chuck	13.18"	1.97"	.78"
EEPM-CIRB220	induction block for CIR500 chuck	8.66"	1.97"	.78"
EEPM-CIRB270	induction block for CIR600 chuck	10.62"	1.97"	.78"

Model	Dim. (O.D. x I.D. x H)	No. Poles	Holding Power	Weight	Control
EEPM-CIR500	19.7" x 0" x 2.75"	12 + 4	12,345 lbs.	229 lbs.	C1
EEPM-CIR600	23.6" x 0" x 2.75"	12 + 4	17,636 lbs.	326 lbs.	C2
EEPM-CIR800	31.5" x 9.84" x 3.34"	16	28,219 lbs.	665 lbs.	C2
EEPM-CIR1000	39.4" x 9.84" x 3.34"	16	42,328 lbs.	1,038 lbs.	C4
EEPM-CIR1250	49.6" x 19.68" x 4.33"	24	52,910 lbs.	1,825 lbs.	C4
EEPM-CIR1500	59.0" x 19.68" x 4.72"	24	74,075 lbs.	2,921 lbs.	C8
EEPM-CIR1600	64.2" x 19.68" x 4.72"	24	84,657 lbs.	3,322 lbs.	C8
EEPM-CIR1800	71.6" x 31.49" x 4.72"	36	111,112 lbs.	5,048 lbs.	C8
EEPM-CIR2000	80.7" x 39.37" x 5.11"	36	111,112 lbs.	5,489 lbs.	C8



MagVISE EEPM-CIRS for Machining & Grinding



For workholding of ferrous materials only.

EEPM chucks includes controller and remote. Control requires a dedicated 480V single phase, 30A power supply

Advantages:

- Versatile round chucks to fit a variety of applications
- Reduce setup & change-over time by 50% or more!
- Machine freely on 5-sides so you can cut the full part profile in only one operation

There are 9 stock sizes of EEPM-CIRS chucks to choose from (see table below). We also can build custom chucks for your machine.

We recommend using induction blocks at all times to preserve the precision ground finish and prevent damage to the face of the chuck. You can easily modify induction blocks to your part requirements. Use EEPM-SP induction blocks for holding warped stock.

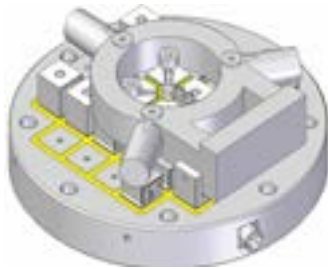

Use induction blocks as workstops to hold hard parts



Machine full 5 sides using induction blocks



Machine nests to hold smaller parts

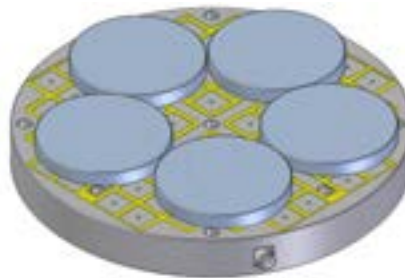

Gang parts together on larger chucks for efficiency

MagVISE
WORKHOLDING

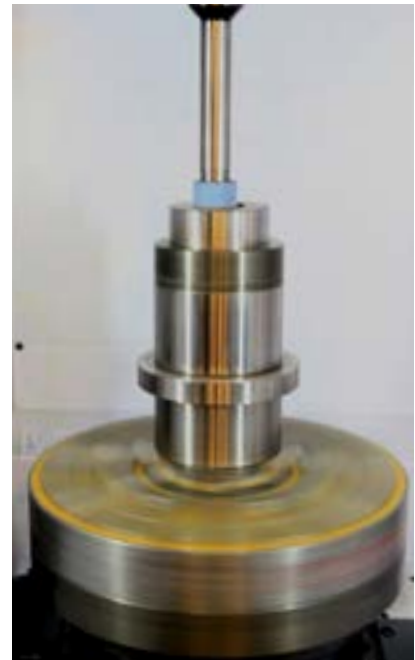

Honing application



Easy integration with 5-axis tables

Model	Dim. (O.D. x H)	No. Poles	Holding Power	Weight	Control
EEPM-CIRS200	7.99" x 2.75"	4	2,204 lbs.	35 lbs.	C1
EEPM-CIRS300	12.0" x 2.75"	12	6,612 lbs.	77 lbs.	C1
EEPM-CIRS500	19.68" x 2.75"	32	17,632 lbs.	214 lbs.	C1
EEPM-CIRS600	24.4" x 2.75"	52	28,652 lbs.	330 lbs.	C2
EEPM-CIRS700	27.55" x 2.75"	76	41,876 lbs.	421 lbs.	C4
EEPM-CIRS800	32.28" x 2.75"	96	52,896 lbs.	578 lbs.	C4
EEPM-CIRS900	35.82" x 3.14"	120	66,120 lbs.	798 lbs.	C4
EEPM-CIRS1000	40.15" x 3.14"	164	90,364 lbs.	1,022 lbs.	C8
EEPM-CIRS1100	45.54" x 3.14"	204	112,404 lbs.	1,203 lbs.	C8

MagVISE EEPM-IT Index Table

Features:

- Pneumatic table makes rotation easy
- Indexed in 5 degree increments
- Full 360° rotation either left or right

Advantages:

- Add indexing capability to your horizontal mill
- Machine 5-sides freely and reduce setup time 50%
- Very uniform holding = No workpiece deformation



For workholding of ferrous materials only.

includes C4 control and remote



Pull the black knob out to un-clamp table and rotate part. Push knob in to clamp. Index table requires 90 psi shop air for rotation.

We recommend using induction blocks or subplates at all times to preserve the precision ground finish and prevent damage to the face of the magnetic chuck.

For more information see page 243.



Scan QR code above or visit: <http://goo.gl/fb4nkk>



Use EZ-Lift lifting magnet to quickly load your workpiece



Pull knob to rotate part up to 360 degrees



Use induction blocks to machine full 5 sides freely



Add indexing capability to your mill

Model	Face (L x W x H)	Max. Load	No. Poles	Holding Power	Squareness	Repeatability	Weight
EEPM-300IT	11.81" x 11.81" x 7.59"	1,100 lbs.	16	11,023 lbs.	.0004"	.0004"	229 lbs.
EEPM-470IT	18.5" x 18.5" x 7.36"	2,200 lbs.	49	33,730 lbs.	.0005"	.0004"	490 lbs.
EEPM-600IT	23.6" x 23.6" x 8.89"	4,400 lbs.	72	49,604 lbs.	.0007"	.0005"	996.5 lbs.
EEPM-800IT	31.5" x 31.5" x 11.88"	6,600 lbs.	144	99,208 lbs.	.0007"	.0005"	2,162.5 lbs.



MagVISE Injection Mold Clamping Magnets



Magnetic mold clamping is much faster than other methods to save machine time.

Injection-mold magnets are quickly replacing traditional mold clamping methods world-wide. The investment in PIM magnets is quickly repaid by faster mold setup and change-over

times. Also, machine capacity increases by an average of 20% because PIM magnets require less room in the machine cube. Call us for custom size magnets.

Features

- Position & clamp in just minutes!
- Proximity sensors ensure position
- Dual controls lock-out machine during operation for safety

Benefits

- Reduce setup & change-over time
- Increase machine capacity 20%
- Greatly increase productivity by just changing clamping method

MagVISE
WORKHOLDING



Watch the video demo at this url:
<http://ow.ly/tajls>



Proximity sensors ensure correct positioning.



Controls require operator to use both hands.



Load and install PIM magnet with bolts



PIM & controls integrate with your machine.

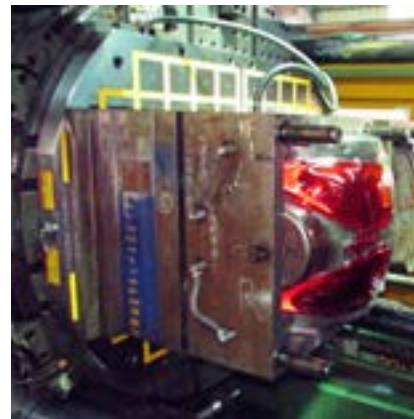

Mold is held perfectly, & change-over is fast.

Model	Face (L x W x H)	Max Temp (F)	Holding Power	Pole Size (mm)	Power Supply
EEPM-1200PIM	59" x 59" x 2.75"	248°	185,188 lbs.	92 x 92	35A, 480V single phase
EEPM-950PIM	57" x 41.3" x 2.75"	248°	148,150 lbs.	92 x 92	30A, 480V single phase
EEPM-400PIM	41.3" x 25.6" x 2.75"	248°	52,910 lbs.	92 x 92	40A, 480V single phase

MagVISE ECB Magnetic Workholding Vises



Features

- Powerful rare-earth magnets for up to 4,620 lbs. holding power (per vise)
- Gang multiple vises together and increase holding power as needed
- Quickly and easily adjust size of setup and number of chucks as needed

Benefits

- Reduce setup & change-over time by 50% or more!
- Freely machine on all 5-sides to reduce operations
- No workpiece deformation

4 sizes available

For workholding of ferrous materials only. Each ECB vise includes everything required to setup and begin workholding.

Scan the QR code or enter this link: <http://ow.ly/u21Nm> to view a video demo.

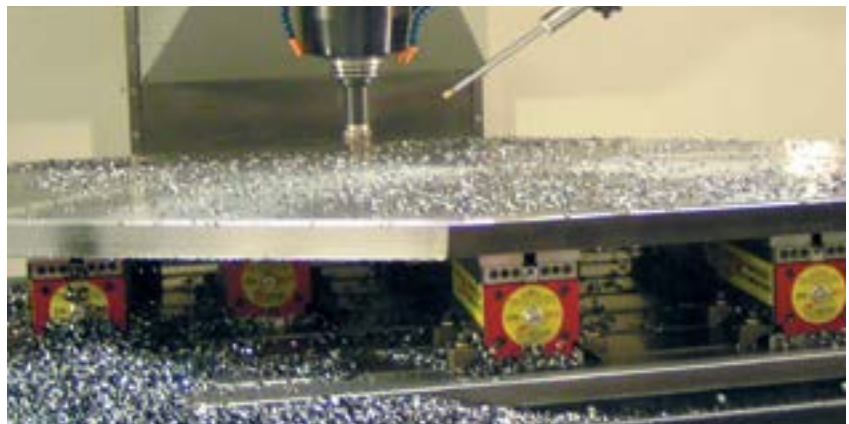

ECB Magnetic Vises provide fast, efficient workholding for all types of CNC machining applications. They are easy to install or move from machine to machine, and making changes to existing setups is fast.

Setup Examples

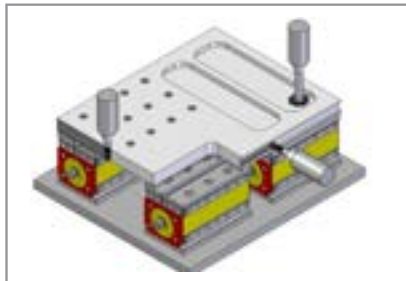

Machine freely on 5-sides using induction blocks

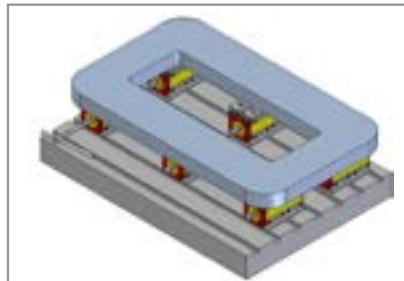

Switch-connect to turn ON/OFF multiple vises

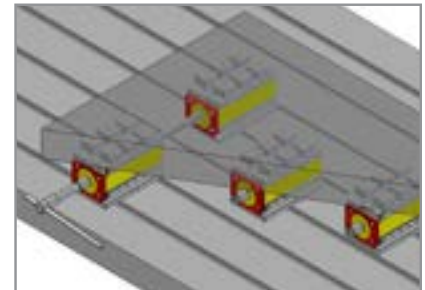

Position ECB vises just where you need them

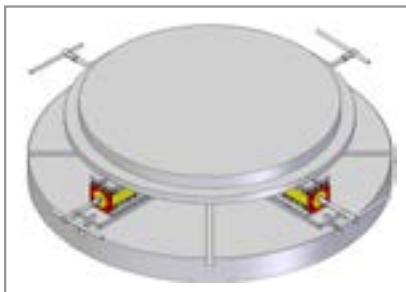

Vertical turning setups are faster with ECB vises

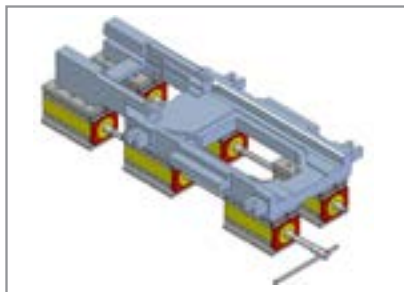

Cut complex part shapes O.D. and I.D.

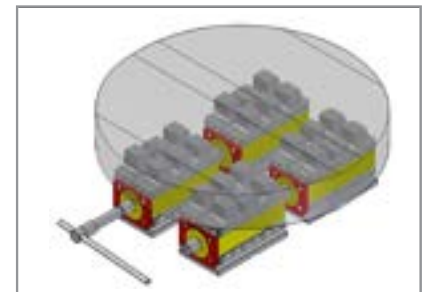

Hold large and small parts of all shapes



MagVISE ECB Applications



You can use 1 ECB vise for each part...



...or use multiple ECB vises positioned as needed to hold large parts.



Machine freely on 5-sides



Switch-connect ECB vises to turn ON/OFF simultaneously



Tombstones for horizontal milling

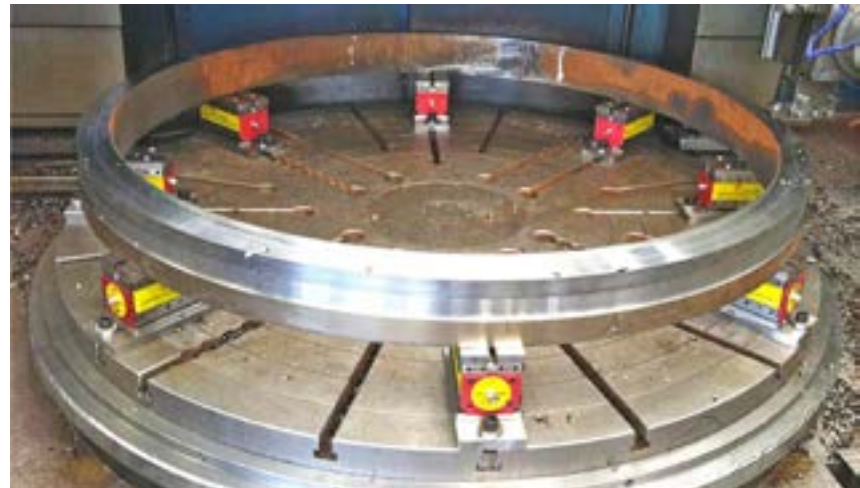

ECB magnetic vises are easy to setup for vertical turning. Machine both O.D. and I.D.



ECB vises are used for large or small parts



Even huge workpieces like this one are easily held and can be machined on 5-sides.

MagVISE
WORKHOLDING

MagVISE ECB Ordering Information



4 sizes available.
Each ECB vise includes 2 machinable induction blocks, wrench, extension and socket, switch-connect socket assembly, 2 stop plates, and 4 toe clamps.



EEPM-SP spring type

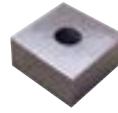

EEPM-SPF solid type

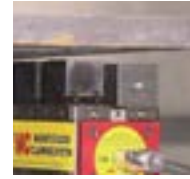

Use EEPM-SP spring-loaded induction blocks and EEPM-SPF blocks together to hold warped stock. See page 243.

Use induction blocks at all times to prevent damage to the face of the magnetic vise. You can easily modify induction blocks to adapt your setup to part requirements. Please note that the spring loaded induction blocks are NOT machineable, but the solid blocks are able to be drilled and machined as required.

After installing your ECB vise we recommend cleanup milling the surface of your induction blocks before loading your work piece to insure that the surface height is uniform and parallel to the spindle.



ECB magnetic vises easily integrate with pallet changing and tombstone systems used in production cells. Call us at (800) 597-3921 or (317) 803-8000 for a fast quote.

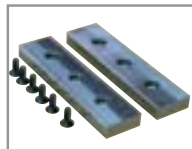

Induction blocks and work stops are included.



Switch-connect vises to turn them ON/OFF in unison.

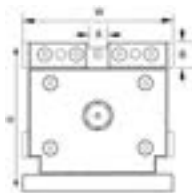

end view

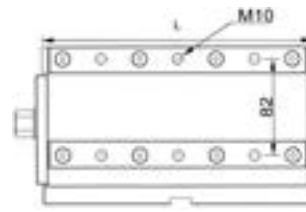

side view

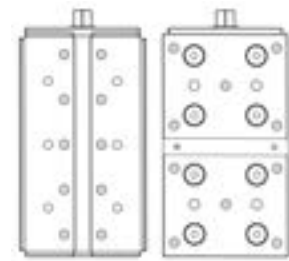

top and bottom view



Ordering Information

Part No.	L x W x H	A	B	Min. Stock Thickness	Holding Power	Weight
ECB-050	5" x 3" x 3"	.47"	.47"	0.4"	1,100 lbs.	15 lbs.
ECB-075	6.8" x 3" x 3"	.47"	.47"	0.4"	1,650 lbs.	19 lbs.
ECB-120	7.3" x 4.2" x 4.2"	.62"	.59"	0.6"	2,640 lbs.	40 lbs.
ECB-210	9.2" x 5.2" x 5.3"	.65"	.84"	0.8"	4,620 lbs.	80 lbs.

Part No.	Description	L x W x H
EEPM-SPF	1, soft fixed induction block, 8mm screw - use with ECB-SP50 spring blocks.	1.97" x 1.97" x 1.23"
EEPM-SP	2, spring loaded induction block, 8mm screw - use with ECB-SPF50 on corners.	1.89" x 1.89" x 1.41"

Note: Holding power depends on workpiece size, material, surface finish, contact area with magnet, and workpiece thickness. Always make sure your read, understand and follow the instructions that come with your ECB vise.



MagVISE EDMT Surface Grinding Chucks



For induction blocks see page 243.

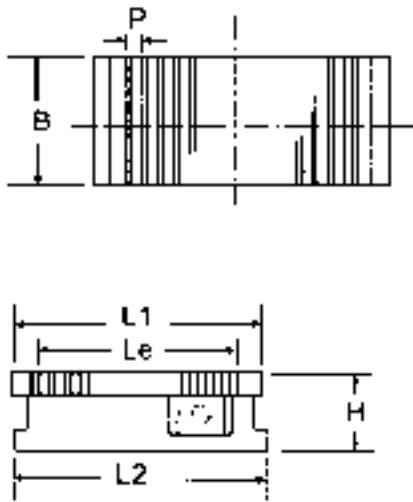

EDMT (All-Purpose Variable Pole Design)

Alternating thick/thin magnetic poles provides best holding power for both thick and thin workpieces.

- *EDM-READY: fully submersible, brass welded faceplate which can be machined if needed, and protects the magnetic system from penetration of coolant.*
- *Needs no electricity. Provides a constant source of workholding power.*
- *Low-profile design increases Z-axis stroke*
- *Housing and bottom plate are free of magnetism —will not magnetize machine bed or bearings.*

Variable Pole

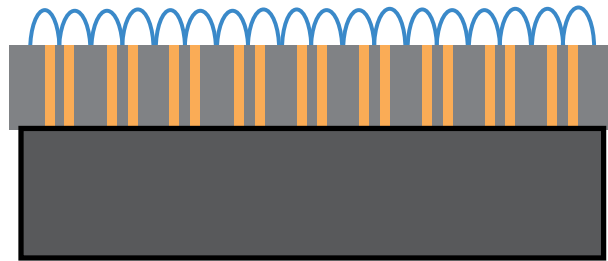

*New variable pole design creates magnetic fields that hold both thin and thick workpieces equally well.

Model	Pole Pitch (P)	L x W x H	Weight
EDMT-1018	11.2 (1.6+2+1.6+6)	7" x 4" x 2.5"	16 lbs.
EDMT-1325	11.2 (1.6+2+1.6+6)	10" x 5" x 2.5"	23 lbs.
EDMT-1530	11.2 (1.6+2+1.6+6)	12" x 6" x 2.5"	33 lbs.
EDMT-1535	11.2 (1.6+2+1.6+6)	14" x 6" x 2.5"	38 lbs.
EDMT-1545	11.2 (1.6+2+1.6+6)	18" x 6" x 2.5"	44 lbs.
EDMT-2040	11.2 (1.6+2+1.6+6)	16" x 8" x 2.5"	57 lbs.
EDMT-2045	11.2 (1.6+2+1.6+6)	18" x 8" x 2.5"	66 lbs.
EDMT-2050	11.2 (1.6+2+1.6+6)	20" x 8" x 2.5"	79 lbs.
EDMT-2550	4 + 12	20" x 10" x 2.5"	130 lbs.
EDMT-3060	3 + 15	24" x 12" x 2.5"	198 lbs.

MagVISE EDTW Fine Pole Surface Grinding Chucks



For induction blocks see page 243.

EDTW (MicroPITCH Fine Pole Design)

Fine pole design provides best holding power for surface grinding of small or thin workpieces.

- Brass welded faceplate can be machined if needed, and protects the magnetic system from penetration of coolant.
- Needs no electricity. Provides a constant source of workholding power.
- Low-profile design increases Z-axis stroke
- Housing and bottom plate are free of magnetism —will not magnetize machine bed or bearings.



EDTW chucks have up to 15 tons of holding force. (150 lbs./inch²)

Fine Pole

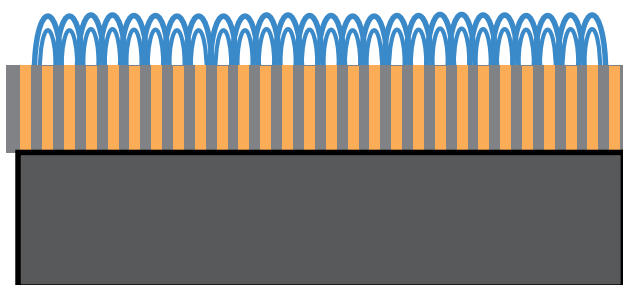

Fine pole magnets creates strongest magnetic field close to surface for holding thin workpieces.

Model	Pole Pitch (P)	L x W x H	Weight
EDTW-1018	2 (1+1)	7" x 4" x 2"	15 lbs.
EDTW-1325	2 (1+1)	10" x 5" x 2.25"	29 lbs.
EDTW-1515	2 (1+1)	6" x 6" x 2.25"	20 lbs.
EDTW-1530	2 (1+1)	12" x 6" x 2.5"	49 lbs.
EDTW-1535	2 (1+1)	14" x 6" x 2.5"	53 lbs.
EDTW-1545	2 (1+1)	18" x 6" x 2.5"	68 lbs.
EDTW-2040	2 (1+1)	16" x 8" x 2.5"	82 lbs.
EDTW-2045	2 (1+1)	18" x 8" x 2.5"	90 lbs.
EDTW-2050	2 (1+1)	20" x 8" x 2.5"	99 lbs.
EDTW-2550	2 (1+1)	20" x 10" x 2.5"	132 lbs.

MagVISE EET Surface Grinding Chucks



For induction blocks see page 243.

EET (Wide Spaced Pole Design)

Wider spacing magnetic poles for general surface grinding of both thick and thin workpieces.

- Brass welded faceplate which can be machined if needed, and protects the magnetic system from penetration of coolant.
- More than 1,000 OHMs resistance
- Low-profile design increases Z-axis stroke
- Housing and bottom plate are free of magnetism —will not magnetize machine bed or bearings.

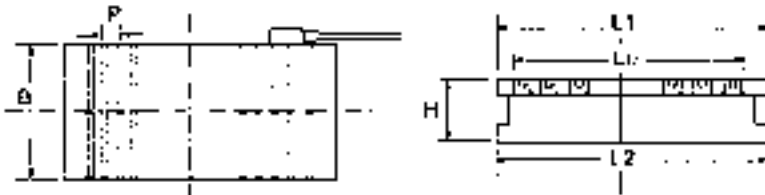

Model	Pole Pitch (P)	L x W x H	Volts	Amps	Weight
EET-1530	15 (3+12)	12" x 6" x 3"	DC90V	0.18	44 lbs.
EET-1535	15 (3+12)	14" x 6" x 3"	DC90V	0.19	53 lbs.
EET-1545	15 (3+12)	18" x 6" x 3"	DC90V	0.19	66 lbs.
EET-2040	15 (3+12)	16" x 8" x 3"	DC90V	0.28	84 lbs.
EET-2045	15 (3+12)	18" x 8" x 3"	DC90V	0.28	90 lbs.
EET-2050	15 (3+12)	20" x 8" x 3"	DC90V	0.36	99 lbs.
EET-2550	15 (3+12)	20" x 10" x 3"	DC90V	0.46	143 lbs.
EET-3060	15 (3+12)	24" x 12" x 3"	DC90V	0.86	179 lbs.
EET-3070	15 (3+12)	28" x 12" x 3"	DC90V	0.81	205 lbs.
EET-3090	15 (3+12)	35" x 12" x 3"	DC90V	1.05	276 lbs.
EET-4060	19 (3+16)	24" x 16" x 3.5"	DC90V	0.95	287 lbs.
EET-4070	19 (3+16)	28" x 16" x 3.5"	DC90V	1.21	333 lbs.
EET-4080	19 (3+16)	32" x 16" x 3.5"	DC90V	1.31	384 lbs.
EET-40100	19 (3+16)	40" x 16" x 3.5"	DC90V	1.33	487 lbs.
EET-50100	19 (3+16)	40" x 20" x 3.5"	DC90V	1.46	595 lbs.
EET-50150	19 (3+16)	60" x 20" x 3.5"	DC90V	3.37	893 lbs.
EET-60100	19 (3+16)	40" x 24" x 3.5"	DC90V	2.80	728 lbs.
EET-60150	19 (3+16)	60" x 24" x 3.5"	DC90V	2.85	1091 lbs.
EET-80100	19 (3+16)	40" x 32" x 3.5"	DC90V	3.80	970 lbs.

MagVISE EET-W Fine Pole Surface Grinding Chucks



For induction blocks see page 243.

EET-W (Fine Pole Design)

Fine pole design optimized for maximum holding power for surface grinding of thin workpieces

- Brass welded faceplate which can be machined if needed, protects the magnetic system from penetration of coolant
- More than 1,000 OHMs resistance
- Low-profile design increases Z-axis stroke
- Housing and bottom plate are free of magnetism —will not magnetize machine bed or bearings.

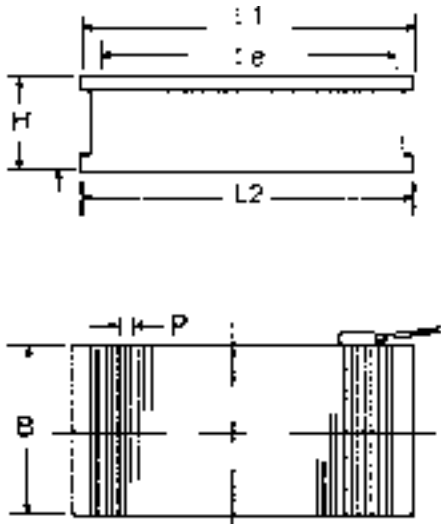

Fine Pole

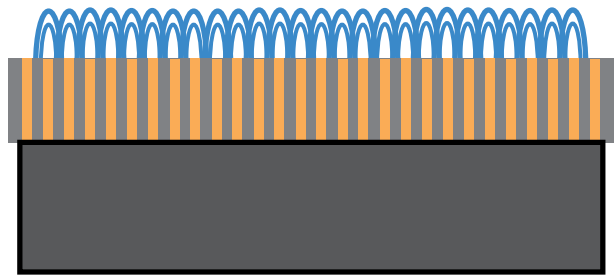

Fine pole magnets creates strongest magnetic field close to surface for holding thin workpieces.

Model	Pole Pitch (P)	L x W x H	Volts	Amps	Weight
EET-1530W	4(1+3)	12" x 6" x 4.5"	DC90V	0.73	73 lbs.
EET-1535W	4(1+3)	14" x 6" x 4.5"	DC90V	0.61	88 lbs.
EET-1545W	4(1+3)	18" x 6" x 4.5"	DC90V	0.98	110 lbs.
EET-2040W	4(1+3)	16" x 8" x 4.5"	DC90V	1.10	139 lbs.
EET-2045W	4(1+3)	18" x 8" x 4.5"	DC90V	1.20	157 lbs.
EET-2050W	4(1+3)	20" x 8" x 4.5"	DC90V	1.40	176 lbs.
EET-2550W	4(1+3)	20" x 10" x 4.5"	DC90V	1.00	247 lbs.
EET-3060W	4(1+3)	24" x 12" x 4.5"	DC90V	1.50	331 lbs.

MagVISE Induction Blocks for Surface Grinding

EHT Induction Blocks:

- Extends magnetic force to hold bar, round, or irregular shapes
- EDM-READY: fully submersible, brass sealed
- For fine-pole and standard pole applications

Choose from lengthwise (L) or width-wise (W) pole direction

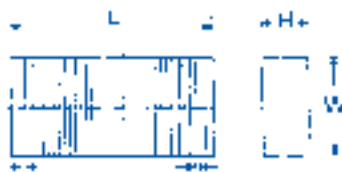

EHT-100
(set of 2)



EHT-150W

EHT-72
(set of 2)



EHT-150L

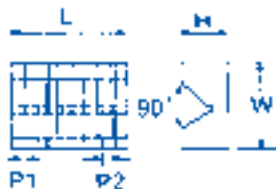

EHT-65V
(set of 2)



EHT-150



EHT-300W (fine pole)



EHT-300L (lengthwise pole)



EHT-300 (width-wise pole)

Model	Qty.	L x W x H	Pole Pitch P1	Pole Pitch P2	Weight
EHT-65V	2	2.5" x 2.5" x 1.5"	2	3	4 lbs. (x2)
EHT-72	2	3" x 2" x 1"	2	3	7 lbs. (x2)
EHT-100	2	4" x 3" x 1.5"	2	3	10 lbs. (x2)
EHT-150	1	6" x 3" x 1"	2	3	5 lbs.
EHT-300	1	12" x 3" x 1"	2	3	10 lbs.
EHT-150L	1	6" x 3" x 1"	2	3	5 lbs.
EHT-300L	1	12" x 3" x 1"	2	3	10 lbs.
EHT-150W	1	6" x 3" x 1"	1+1	1+1	5 lbs.
EHT-300W	1	12" x 3" x 1"	1+1	1+1	10 lbs.

MagVISE Magnetic V-Blocks

ECE Magnetic Blocks

- Dozens of uses around the shop
- Fast setups of bar stock or round steel
- Powerful magnetic base, ON-OFF switch



ECE-100 / ECE-150

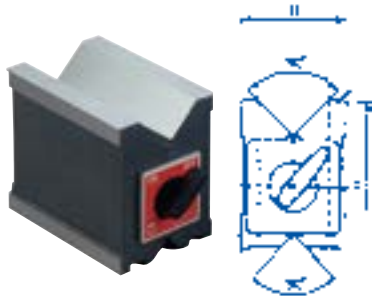

ECE-208 / ECE-212



ECE-612



Model	Holding Power		Dimensions mm								Weight
	V-Face	Surface	B	L	H	C	H1	H2	S1	S2	
ECE-100	61 lbs.	88 lbs.	100	100	100	-	-	-	-	-	14.5 lbs.
ECE-150	110 lbs.	308 lbs.	150	150	150	-	-	-	-	-	53 lbs.
ECE-208	121 lbs.	154 lbs.	56	80	72	-	-	-	-	-	6.5 lbs.
ECE-212	198 lbs.	242 lbs.	75	115	100	-	-	-	-	-	11 lbs.
ECE-612	242 lbs.	350 lbs.	76	118	62	50	50	12	48	62	5.5 lbs.

ECE Magnetic V-Block Sets

- For grinding, marking, measuring and other light machining operations
- Each pair made to identical dimensions
- Sold in pairs only



ECE-507



ECE-510

Model	Holding Power	Applicable Diameter mm	Dimension mm			Weight
			B	L	H	
ECE-507	33 lbs.	50	40	72	50	2.2 lbs. x 2
ECE-510	44 lbs.	80	50	100	80	6.6 lbs. x 2

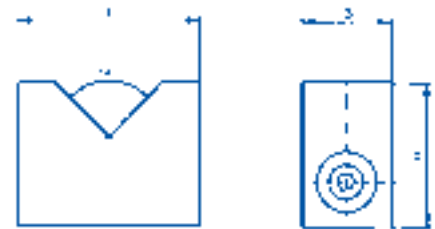

Chuck Controls and Demagnetizers

ERD-505, 510, 515 Features:

- Work with any electromagnetic chucks
- Demagnetizing time is 6-15 seconds
- Precisely regulates the magnetic force

ERD-520 Features:

- For larger, more powerful electromagnetic chucks
- Can operate two chucks at the same time
- Demagnetizing time is 8-15 seconds



ERD-505



ERD-510, ERD-515



ERD-520

Model	Input Voltage/Single Phase	Output Volts	Output Amps	Dim. L x W x H	Wt.
ERD-505-110	AC 110/220V	DC 0-100V	5A	8" x 5.5" x 5"	8 lbs.
ERD-510-220	AC110/220/440V	DC 0-120V	10A	6" x 13" x 10"	33 lbs.
ERD-515-220	AC 220/440V	DC 0-120V	15A	6" x 13" x 10"	44 lbs.
ERD-520-220	AC 220/440V	DC 0-120V	20A	7" x 15" x 12"	71 lbs.

Please specify voltage when ordering.

EDH Demagnetizers



EDH-123



EDH-180



EDH-200

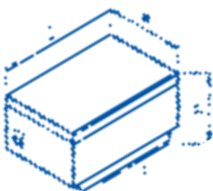

Model	Description	Power	Capacity	Duty Cycle	Dim. L x W x H	Wt.
EDH-123-110	Portable, light weight, for big machines	AC 110V	110VA	90%	123 x 83 x 83mm	4 lbs.
EDB-180-110	Up to 20 minutes continuous operation	AC 110/220V	220VA	50%	127 x 180 x 90mm	9 lbs.
EDS-200-110	Continuous operation, double-coil design	AC 110V	330VA	100%	150 x 200 x 100mm	19 lbs.

MagVISE
WORKHOLDING

EZ-Lift Magnets – sPINner Small Parts Deburring



Small Parts Deburring

- *batch deburr small parts*
- *stop hand deburring*
- *save time & money*



Built for Speed.

All Techniks products are backed by our 100% satisfaction guarantee!

EZ-Lift Material Handling Magnets



Features

- 3.5X max rating for safety
- Lift flat or round stock
- Capacity up to 6,600 lbs, ...higher with spreader bars

Benefits

- Will not wear out like straps/slings
- Less risk of pinched fingers/toes
- Much faster setup and transport

Best Safety Factor Available

All our lifting magnets have a safety factor of 3.5 times the maximum rated load.



ELM-100 (right) weighs 5.5 lbs. and lifts 220 lbs.



Watch live demonstration video for more information. Scan QR code or visit: <http://ow.ly/10hUB>

How It Works:



Lever in the "ON" position engages safety lock.

The "OFF" position.

Smallest, Most Powerful Lifter – With The Industry's Best Safety Factor (3.5 X Above Maximum Rated Load)

ELM lifters feature super-powerful rare-earth neodymium iron boron lifting magnets that require no electricity and have dozens of uses. Load and unload plate, block, or round steel and iron stock. Use them on press molds, machined parts, and other ferrous materials. Use spreader bars to lift large material.

Each ELM lifting magnet contains super powerful rare earth magnets arranged in 3 rows. The OFF position is when the magnetic poles are in alignment as shown (top left).

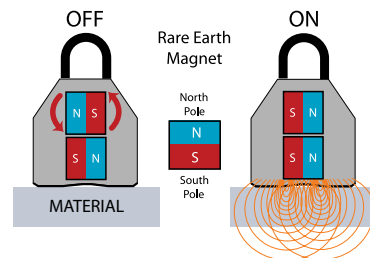

Turning the lever to the ON position rotates the center row of magnets 180° so the poles alternate, creating a powerful magnetic field.

Never attempt to turn the magnet ON unless it is placed on a correctly sized piece of material, or you may cause injury to yourself, or the ELM lifting magnet. Always follow all instructions carefully.

The Old Way: Material Handling

A) Risk of Injury

Risk of injury to back, fingers, or toes when moving material in order to position sling or chain.

B) Slings & Chains Wear Out

Lifting equipment needs to be recertified and replaced periodically.

C) Lost Productivity

It takes time to properly setup slings or chains to safely move materials.

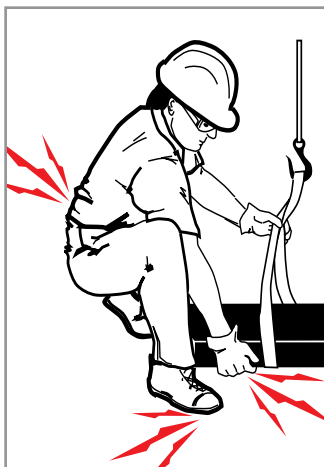

EZ-Lift Application Examples



3.5 X Safety Factor above rated load capacity



Workpiece transport is faster with EZ-Lift.

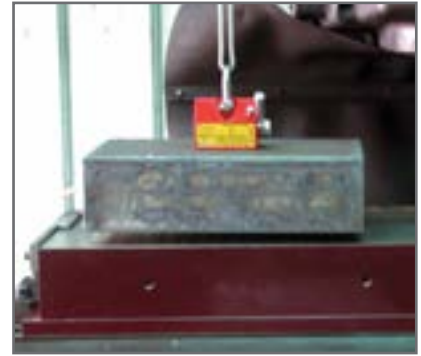

Use to setup CNC machining centers.



Use spreader bars for long, difficult round stock



Center magnet on most workpieces to lift.



Beveled bottom surface lifts round stock.



Eliminate straps, slings and associated dangers.



Locate magnet at balance point for lifting.



Use spreaderbars to gang stock in one operation



Vertical Lifters can be operated by one person.



Move round or rectangular stock vertically.



Spreader bars are used for long or very heavy loads.

EZ-Lift Magnets Ordering Information

EZ-Lift Capacities – Plate & Round Steel

CAUTION: Follow all directions in the Operating Instructions that comes with your magnet.

Refer to the instructions for Calculating Maximum Loads on the next page to determine required size.

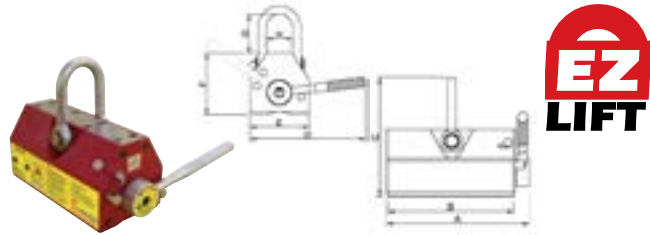

Part No.	Plate	Round	A	B	C	D	E	F	G	H	Weight
ELM-100	220 lbs.	99 lbs.	4.2"	3.3"	4.7"	4.9"	2.4"	2.8"	1.6"	1.2"	5.5 lbs.
ELM-300	660 lbs.	300 lbs.	7.1"	6.1"	6.1"	7.3"	3.6"	3.7"	2.0"	1.6"	18.9 lbs.
ELM-600	1,320 lbs.	600 lbs.	10.0"	8.8"	8.3"	10.2"	4.5"	4.7"	3.0"	2.0"	46 lbs.
ELM-1000	2,200 lbs.	990 lbs.	11.0"	9.6"	11.3"	14.6"	6.5"	6.7"	3.8"	3.4"	101 lbs.
ELM-2000	4,400 lbs.	1,980 lbs.	16.6"	15.0"	13.7"	20.2"	8.5"	8.5"	4.1"	4.8"	259 lbs.
ELM-3000	6,600 lbs.	2,970 lbs.	22.3"	20.9"	15.7"	30.3"	8.5"	8.7"	5.8"	3.2"	399 lbs.

EZ-Lift Spreader Bars

- Better for unbalanced loads
- Use with multiple magnetic lifters
- Lifter span adjustable

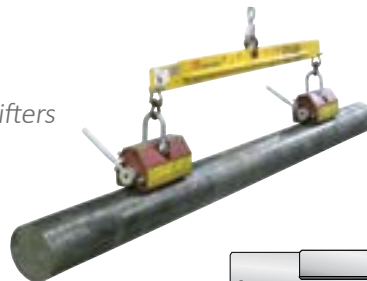

Keeps large materials balanced for safer transport.

Control large or irregular loads during transport. Increase lifting power by adding more magnets. Includes bar, 1 upper and 2 lower S.P.A. shackles. Order magnets separately.

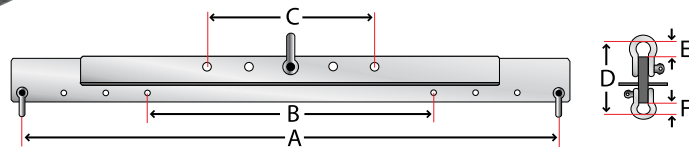

Part No.	Capacity	A	B	C	D	E	F	Weight
ELM-SB250	250 lbs.	36"	18"	12"	5.1"	1.25"	.85"	20 lbs.
ELM-SB500	500 lbs.	46"	22"	16"	5.7"	1.35"	1.34"	25 lbs.
ELM-SB1000	1,000 lbs.	72"	36"	24"	6.9"	1.35"	1.34"	65 lbs.
ELM-SB2000	2,000 lbs.	72"	36"	24"	7.3"	2.02"	1.35"	115 lbs.
ELM-SB4000	4,000 lbs.	77"	41"	24"	10.5"	2.43"	1.63"	195 lbs.
ELM-SB8000	8,000 lbs.	96"	48"	24"	12.3"	2.94"	1.78"	300 lbs.
ELM-SB10000	10,000 lbs.	116"	56"	24"	14.7"	3.5"	1.65"	600 lbs.
ELM-SB13500	13,500 lbs.	140"	68"	36"	17.1"	4.0"	2.02"	880 lbs.

EZ-Lift Vertical Lifters

- Fast loading for vertical transport
- One person can load and unload
- No dangerous straps & slings



Used for vertical transport of plate stock. Includes ELM lifting magnet.

Plate Size L x W x H (min/max)

Part No.	Size L x W x H	Capacity	Weight	L	W	H
ELM-300V	37.5" x 8.5" x 10"	660 lbs.	57 lbs.	8"/60"	11.8"/31.5"	0.25"/5.9"
ELM-600V	46" x 11" x 10"	1,320 lbs.	86 lbs.	12"/72"	11.8"/39.4"	0.31"/9.8"
ELM-1000V	48" x 14" x 12"	2,200 lbs.	128 lbs.	12.5"/79"	11.8"/39.4"	0.39"/11.8"



Position lifter on stock and turn the lever to the on position. Hoist into vertical position for transport. Always follow operating instructions included.

EZ-Lift Magnets / Calculating Maximum Loads

Instructions for Calculating Maximum Load by Material Type

$$T \text{ (thickness)} \times F \text{ (finish)} \times M \text{ (material)} \times \text{Capacity} = \text{ML}$$

Example: (ELM-600/plate steel) 2" (T=100%) x F2(100%) x M2 (85%) x 1,320 lbs. = **1,122 lbs.**

Calculating Maximum Loads

Calculate that the magnet will safely lift your material. Maximum Load (ML) is different for plate and round materials, and also depends upon stock thickness, carbon content, and surface finish. Follow the instructions and use the tables to calculate ML for your material type.

Rated Capacity

Part No.	Plate Steel*
ELM-100	220 lbs.
ELM-300	660 lbs.
ELM-600	1,320 lbs.
ELM-1000	2,200 lbs.
ELM-2000	4,400 lbs.
ELM-3000	6,600 lbs.

Part No.	Round Steel*
ELM-100	99 lbs.
ELM-300	300 lbs.
ELM-600	600 lbs.
ELM-1000	990 lbs.
ELM-2000	1,980 lbs.
ELM-3000	2,970 lbs.

M Lifting Power by Material

Carbon Content	0%	50%	100%
	M1 Low Carbon		
M2 Moderate Carbon			85%
M3 High Carbon			75%
M4 Cast Iron			70%

F Effect of Surface Finish

Surface Finish	0%	50%	100%	150%
	F1 Ground Surface			
F2 Rough Machined			100%	
F3 Foundry Finish			90%	
F4 ~ Rough Cast		65%		

T Equals Percent of Lifting Power by T (thickness)

T	ELM-100	ELM-300	ELM-600	ELM-1000	ELM-2000	ELM-3000
2 3/8" (60mm)	100%	100%	100%	100%	100%	100%
2 1/8" (55mm)	100%	100%	100%	100%	100%	95%
2.0" (50mm)	100%	100%	100%	100%	95%	90%
1 3/4" (45mm)	100%	100%	100%	100%	90%	85%
1 1/2" (40mm)	100%	100%	100%	100%	85%	80%
1 3/8" (35mm)	100%	100%	100%	90%	75%	70%
1 1/8" (30mm)	100%	100%	100%	80%	65%	60%
1.0" (25mm)	100%	100%	90%	70%	55%	50%
3/4" (20mm)	100%	90%	75%	60%	45%	40%
1/2" (15mm)	100%	70%	60%	50%	35%	30%
3/8" (10mm)	70%	50%	45%	35%	25%	20%
1/4" (5mm)	40%	30%	25%	20%	15%	10%

*Follow all directions in the Operating Instructions that comes with your magnet.

Custom Lifting Solutions

Engineered to meet your requirements.

Call (800) 597-3921 for a fast quote.



sPINner Small Parts Deburring

The sPINner machine batch deburrs small precision parts **FAST!**

- medical parts - swiss turned
- drilled or threaded parts
- machined or stamped parts

- eliminate hand deburring
- deburr parts faster & better
- improve quality of parts



Send us your parts for free testing. See what the sPINner can do for you.



Send your parts to Techniks and our deburring specialists will deburr your parts and provide a complete report including media used, deburring time, and photo results.

Techniks sPINner Deburring
9930 East 56th St.
Indianapolis, IN 46236

Reduce Your Small Parts Deburring Costs

The sPINner deburrs both internal and external part features.

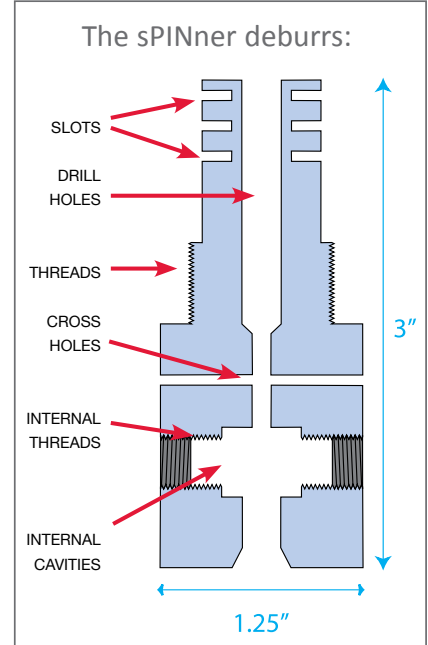
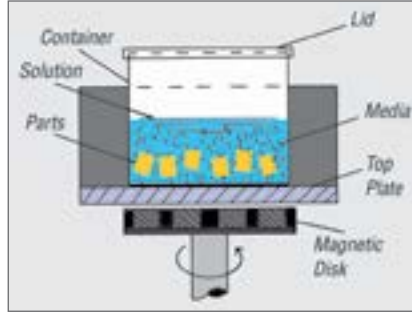

The sPINner machine quickly batch deburrs dozens or even hundreds of small, precision parts produced on machining centers, swiss-type screw machines, and lathes. This includes ferrous and non-ferrous parts produced for the medical, electronics, and other industries.

The sPINner's unique, stainless steel pin media removes light burrs and flash without harming the part. Because the media is magnetically activated it can *deburr internal cavities, slots, holes, and even blind holes*. All parts are automatically demagnetized at the end of the cycle.

Deburring setup and machine operation

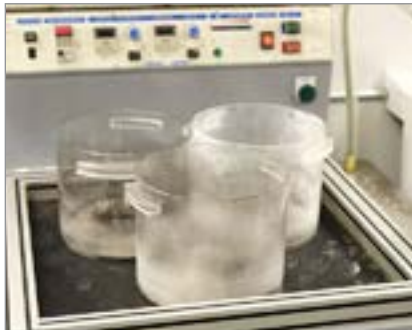

1. Setup your deburring containers on the sPINner. Use multiple containers to increase capacity if needed.

2. Put your pin media and parts into container and fill with water until parts are submerged. Add PFS-747 deburring solution 50:1 ratio.

3. Set the time, speed and duration and press the start button. The sPINner alarm will sound when deburring is complete.

Typical deburring duration is 10-20 minutes. Each sPINner includes adjustable speed & intensity controls with programmable timers for each direction.

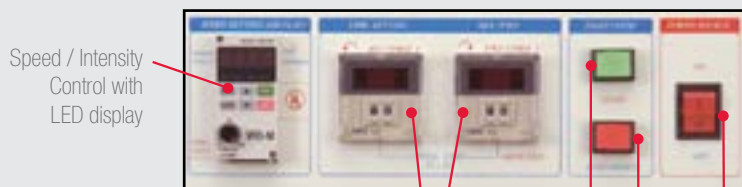

EHD-728 control shown

Programmable Timers (clockwise & counter clockwise)

Cycle Start
Cycle Stop

Power



See the sPINner in action on our youtube channel.

<http://ow.ly/X03Nc>



Six Case-Study Application Examples

sPINner Key Points

- A. Deburring is fast and media will not harm part or affect tolerances
- B. Deburrs parts 100% inside & out. Deburrs where hand deburring cannot
- C. Great for irregular parts, internal holes, blind angles, cavities, etc.
- D. sPINner media lasts 3-5 years and is safe to handle during operation
- E. Filtration system and parts separator available for high volume needs

Other Applications Include:

- Surface polishing
- Pre-electroplating processing
- Removing heat treat scaling
- Oxidized grease/film cleaning
- Removing rust/cleaning threads

1. Aluminum Gear Application

Burrs and rough edges. Deburred part in 10 minutes.
Part Dimensions: 1 9/16" diameter x 5/16" high.



before



after

2. Complex Turned & Machined Aluminum

Burrs on O.D. and in I.D. slots. Batch deburring in 10 minutes.
Part Dim. 3/16" diameter x 1 3/16" long.



before



after

3. Aluminum Cooling Fins

Long burrs and rough edges. Deburred part in 15 minutes.
Part Dim. 4.75 x 2.125" x 2.75"



before



after

4. SCUBA Regulator Valve Part (4140 steel)

Burrs and flash left behind. Batch deburred parts in 10 minutes.
Part Dim. 1.25" diameter x 1.25" long.



before



after

5. Stainless Steel Turned and Machined Part

Internal cavity burrs left in cross-drilled holes
Eliminated costly hand deburring and improved quality.
Part Dim. 3/4" diameter x 1 7/16" long.



before



after

6. Slot in Light Alloy Collar 0.01" Diameter

Fine burrs in hard-to-reach slotted area.
Eliminated part quality problem and saved labor costs.
Part Dimensions: 1 7/32" diameter x 1/8" high.



before



after

sPINner Machines and Media

Machines include: 1 deburring container, 1 gallon PFS-747 deburring solution, a media sieve, and operations manual. Media is specific to your part (see below). For high-volume deburring needs order the EDH-SFS200 filtration system and 660 parts and media separator with your machine.



sPINner Media is made from SUS 304 stainless steel and hardened to HRC 30, with a magnetic treatment that enhances deburring action. It is sold in 2.2 lb. packages. Contact Mike Smalley at 877.354.3837 for assistance selecting the right media for your part.

Use a diameter of media bigger than 0.5mm to deburr hard materials (stainless steel etc.) or if you need to increase deburring power. Use diameters less than 0.5mm for soft material (brass, copper, aluminum) To deburr small holes, choose a pin diameter smaller than the hole. 3mm length media will work better for small holes and crevices.



Filtration unit continuously cleans deburring fluid, minimizing machine downtime for water changes.



660 parts / media separator



PFS-747 1-gallon
PFS-7475G 5-gallon

PIN No.	Dia. x Length	Size	PIN No.	Dia. x Length	Size	PIN No.	Dia. x Length	Size
EHD-S1	0.2mm x 5mm	—	EHD-P5	0.7mm x 3mm	—	EHD-P10	1.2mm x 3mm	—
EHD-P1	0.3mm x 3mm	—	EHD-S5	0.7mm x 5mm	—	EHD-S8	1.2mm x 5mm	—
EHD-S2	0.3mm x 5mm	—	EHD-P6	0.8mm x 3mm	—	EHD-P42	1.2mm x 10mm	—
EHD-S13	0.3mm x 7mm	—	EHD-S6	0.8mm x 5mm	—	EHD-P9	1.5mm x 3mm	—
EHD-P2	0.4mm x 3mm	—	EHD-P7	1.0mm x 1mm	—	EHD-S9	1.5mm x 5mm	—
EHD-S3	0.4mm x 5mm	—	EHD-P8	1.0mm x 3mm	—	EHD-A3	1.5mm x 7mm	—
EHD-P3	0.5mm x 1mm	—	EHD-S7	1.0mm x 5mm	—	EHD-P43	1.5mm x 10mm	—
EHD-P4	0.5mm x 3mm	—	EHD-A1	1.0mm x 7mm	—	EHD-S10	2.0mm x 5mm	—
EHD-S4	0.5mm x 5mm	—	EHD-P41	1.0mm x 10mm	—			

Machine No.	L x W x H	Tank Size L x W	Container W x H	Power Supply	Amps	Weight
EHD-728	19" x 19" x 37"	11" x 11"	9" x 8"	220V single phase	5	160 lbs.
EHD-735	23" x 26" x 34"	15" x 16"	13" x 9"	220V single phase	10	220 lbs.
EHD-750	29" x 30" x 36"	21" x 23"	19" x 10"	220V single phase	15	385 lbs.
EHD-765	37" x 39" x 43"	29" x 26.75"	25" x 10"	220V single phase	10	516 lbs.
EHD-7200	58" x 26.5" x 43"	50" x 14"	32" x 12"	220V three phase	15	1,100 lbs.
EDH-SFS200	12" x 12" x 40"	N/A	N/A	110V single phase	5	75 lbs.
ESS-660	18" x 18" x 26"	18" x 18"	N/A	110V/220V	15	97 lbs.



“One Twist” Indicator Arms (hydraulic & mechanical)

ECE Indicator Arms Features

- "One Twist" 360° adjustable joints
- Check concentricity on bench or your machine
- Powerful magnetic base

Advantages of Hydraulic Arms

- Hydraulic arms are faster, stronger, and more precise than mechanical joints
- Hydraulic joints make fine adjustments easy because they don't lose position when loosened like mechanical arms



Indicator Arms are used to check concentricity on bench or machine. Dial Indicators not included.



ECE-300 series

ECE-330 series

ECE-340

Part No.	Description	Arm Length	Base Dim. Lmm x Wmm x H	Holding Power	Weight lb.
ECE-300ALL	Precision hydraulic arm, gold	23 1/2"	4 3/4"mm x 2"mm x 2 1/8"	352 lbs.	7.75
ECE-300AL	Precision hydraulic arm, gold	16 3/4"	3 1/8"mm x 2"mm x 2 1/8"	220 lbs.	5.5
ECE-300B	Precision hydraulic arm, gold	13 3/8"	2 3/8"mm x 2"mm x 2 1/8"	176 lbs.	4.5
ECE-330AL	Precision mechanical arm, red	16 3/4"	3 1/8"mm x 2"mm x 2 1/8"	220 lbs.	5.0
ECE-330B	Precision mechanical arm, red	13 3/8"	2 3/8" x 2" x 2 1/8"	176 lbs.	3.75
ECE-340	Standard mechanical arm, red	13 3/8"	2 3/8" x 2" x 2 1/8"	176 lbs.	3.5